

SERVICE INFORMATION

Volvo Truck Corporation



Wiring diagram

FE

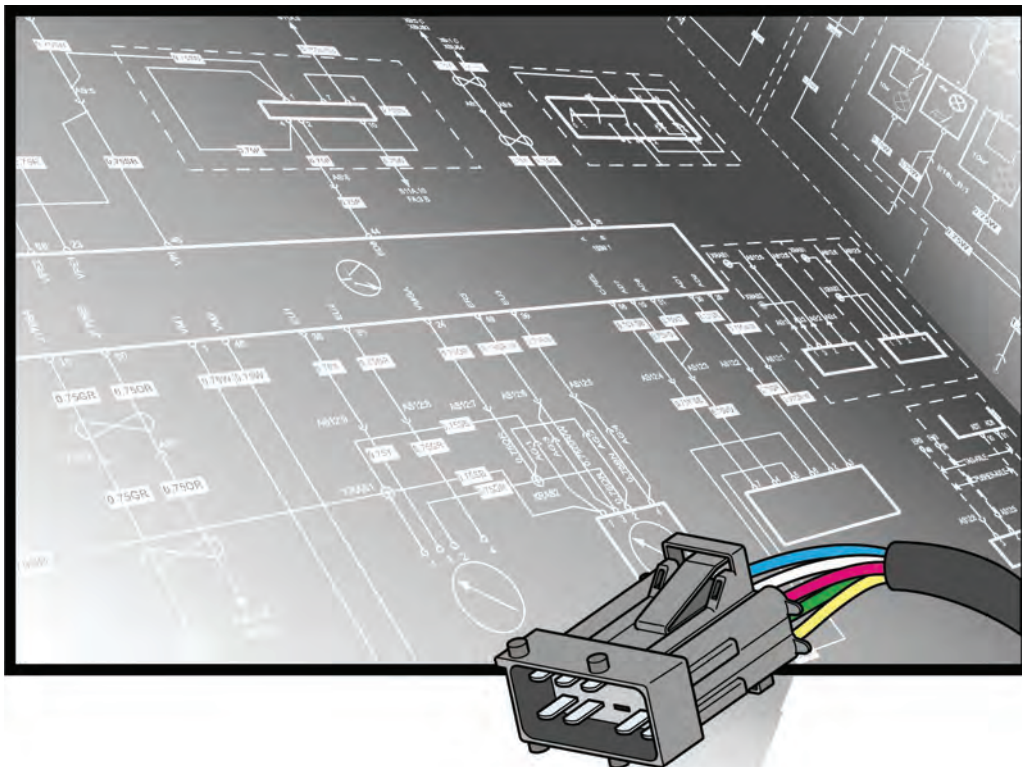

Foreword

The descriptions and service procedures contained in this manual are based on designs and methods studies carried out up to May 2012.

The products are under continuous development. Vehicles and components produced after the above date may therefore have different specifications and repair methods. When this is judged to have a significant bearing on this manual, an updated version of this manual will be issued to cover the changes.

The following levels of observations, cautions and warnings are used in this Service Documentation:

Note: Indicates a procedure, practice, or condition that must be followed in order to have the vehicle or component function in the manner intended.

Caution: Indicates an unsafe practice where damage to the product could occur.

Warning: Indicates an unsafe practice where personal injury or severe damage to the product could occur.

Danger: Indicates an unsafe practice where serious personal injury or death could occur.

Volvo Truck Corporation
Göteborg, Sweden

Order number: 89046088

Repl: Service Manual group 37 88917383

©2012 Volvo Truck Corporation, Göteborg, Sweden

All rights reserved. No part of this publication may be reproduced, stored in retrieval system, or transmitted in any forms by any means, electronic, mechanical, photocopying, recording or otherwise, without the prior written permission of Volvo Truck Corporation .

Contents

Example of wiring diagram.....	1
Component wiring diagram index.....	6
Component wiring diagrams.....	9
Illustrations index.....	96
Illustrations.....	97
Fuses.....	147
Relays.....	149
Wiring harness illustration index.....	151
Ground connections.....	154
List of connectors.....	159
List of wiring numbers.....	213
List of components.....	216
Abbreviations.....	222
Feedback.....	223

Example of wiring diagram

Component wiring diagram title, variant/subtitle and symbol.

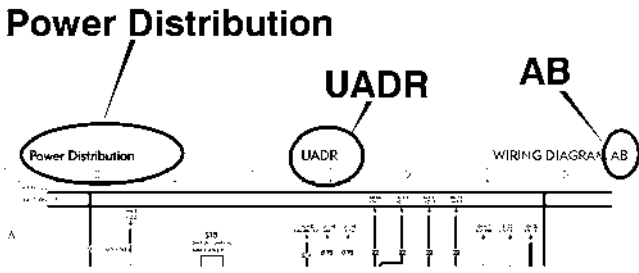

Coordinates (B 1).

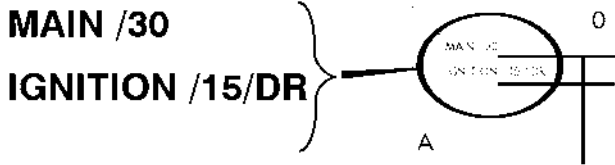
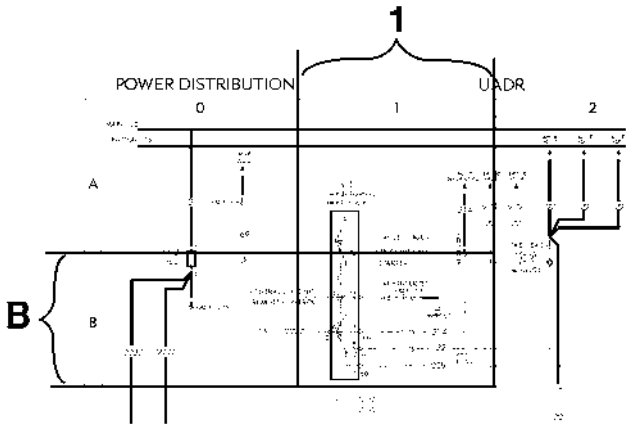

30 Voltage battery, kl.30.
15 Voltage with starter key in drive position and start position, kl.15/kl.DR.

Splice.

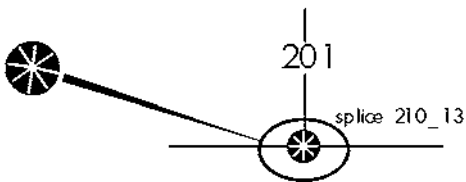

Fuse.

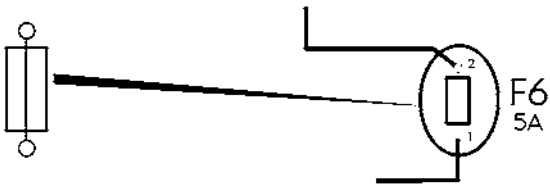

Reference arrow, for diagram AA, coordinates 0 C, component K51B, connector C pin 1.

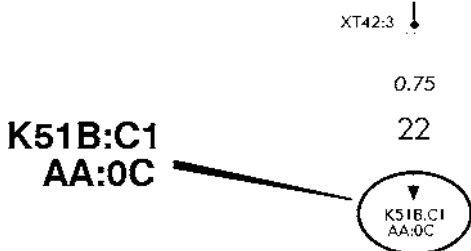

The maximum of variants are drawn, think about that all wires and components are not standard for all markets or vehicle models.

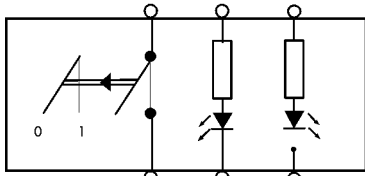
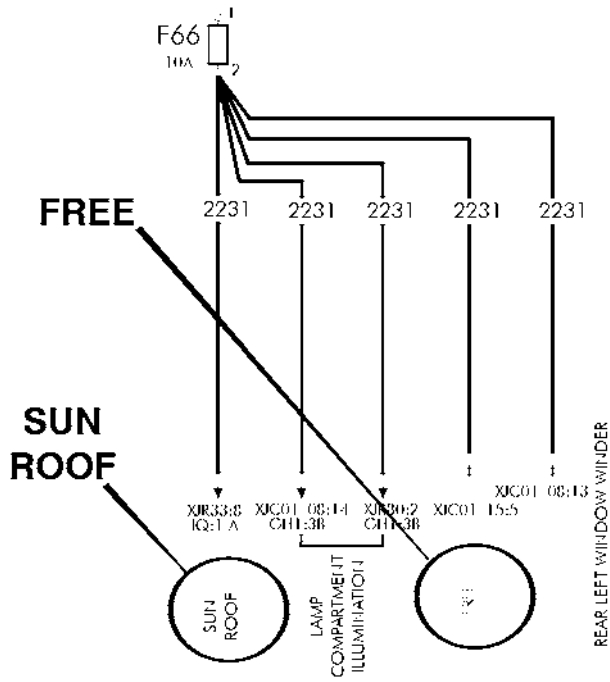

Switch.

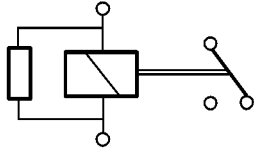

Relay.

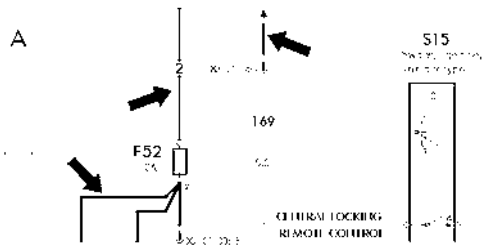

Conductor on circuit card.



Connector EN terminal 1.

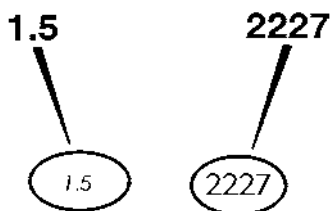

Wire area and wire number.

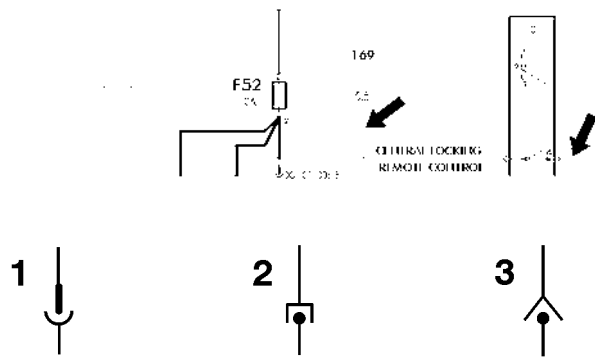

Thin lines, wires.

Connector.

- 1 EJB connectors.
- 2 Pass through connector chassis-cab.
- 3 Others.

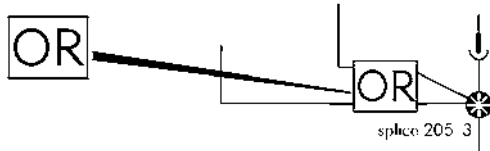

“OR” It is an exclusive OR (only one possibility) between the different solutions due to the configuration of the vehicle.

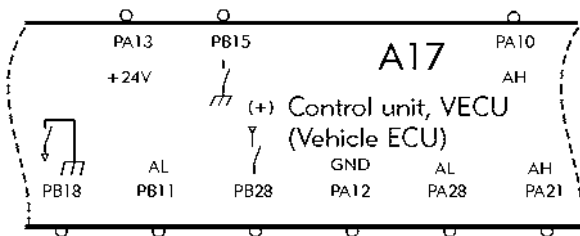

Electronic Control unit.

The inputs/outputs of ECUs are symbolized in the way described below:

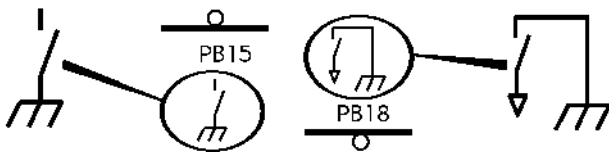

2 alternative of digital output low (set to the ground).



Digital output high (set to 24V, 5V...).



Ground of ECU.

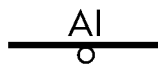

Analog input.

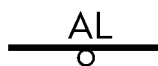

Active low.

AH
○

Active high.

Ending resistance of communication bus CAN (120 Ω)

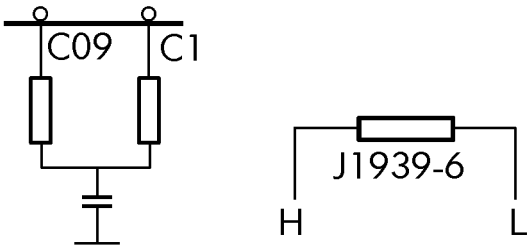

Wire number

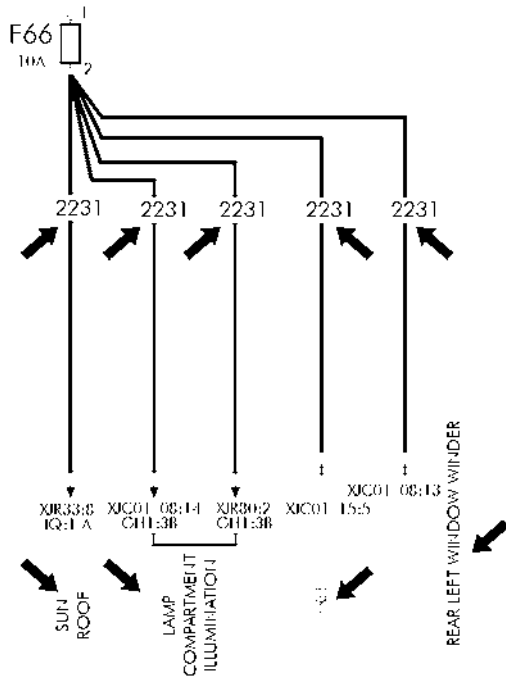

T3018844

Wire equipotential: Equipotential is a wire propriety which characterize a signal flowing a wire (same signal = same equipotential). Several wires could have the same equipotential.

The first digit of the number	Family
1	Ground and negative supply
2	Positive supply
3	Signal
4	Comfort accessories
5	Security accessories
6	Lighting
7	Instrumentation
8	Body builder
9	Free
0	Electronic/Data link

Starting switch

Switch logic diagram.

Terminal	Key in position								
	Key inserted	—	“0”	—	“I”	—	“II”	—	“III”
Key inserted									
Off									
Accessories (pos. 5)									
+15/DR									
50									

Component wiring diagram index

AA	Power supply, starting system, UADR	“” , page 9
AB	Power distribution, UADR	“” , page 10
AB_Hyb	Power distribution.....	“” , page 11
AC	Power supply, starting system, ADR	“” , page 12
AE	Power distribution, ADR	“” , page 13
AG	Accessories power supply.....	“” , page 14
AH	Power supply, kl.15, relay K10	“” , page 15
AI	Power supply, kl.15, relay K21	“” , page 16
AJ	Power supply, kl.15, relay K27	“” , page 17
BA	Vehicle ECU	“” , page 18
BA1	Vehicle ECU	“” , page 19
BK	Instrument cluster	“” , page 20
BM	Tachograph	“” , page 21
BT	Fleet management system Gateway (FMS).....	“” , page 22
CU20	Engine ECU (B connector).....	“” , page 23
CU21	Engine ECU (A connector).....	“” , page 24
CU22	Engine air preheater, fuel heater.....	“” , page 25
CU23	Engine ECU NOXCARE system	“” , page 26
CU50_Hyb	PEC - electric machine.....	“” , page 27
CU51_Hyb	600VDC/400VAC - electrical pump	“” , page 28
CU52_Hyb	600VDC/24VDC - HVJB, hybrid area.....	“” , page 29
CU53_Hyb	ESS/HPCU hybrid area.....	“” , page 30
DC	Single H (ZTO1109/STO1309).....	“” , page 31
DN	OPTIDRIVER 2 (AT2412D).....	“” , page 32
DQ	Power take off	“” , page 33
DQ1	Automatic transmission	“” , page 34
DU	Differential lock.....	“” , page 35
EM1	EBS ECU, connector X1/X2.....	“” , page 36
EM2	EBS ECU, connector X3/X4.....	“” , page 37
EN1	EBS front modulators	“” , page 38
EN3	EBS rear modulators (drive axle).....	“” , page 39
EN4	EBS rear modulators (tag/pusher axle).....	“” , page 40
FA	Air-suspension, TRACTOR 4x2 FSS-LEAF	“” , page 41
FA1	Air-suspension, 4x2 RIGID/4x2 TRACTOR FSS-AIR	“” , page 42
FA2	Air-suspension, 6x2.....	“” , page 43
FC	Air power management (battery box left).....	“” , page 44
FC1	Air power management (battery box right).....	“” , page 45

FO	Electronic steered axle.....	“”	, page 46
GA1	Parking lights, Relay K31/K37.....	“”	, page 47
GA2	Parking lights, Relay K34.....	“”	, page 48
GB1	Low beam/high beam headlights control.....	“”	, page 49
GB2	Fog lights control, extra high beam headlights control.....	“”	, page 50
GC2	Side lights and beacon warning lights.....	“”	, page 51
GC3	Rear lamps.....	“”	, page 52
GC4	Frame side lights.....	“”	, page 53
GC5	Headlight lamps.....	“”	, page 54
GD	Reverse lights/brake lights.....	“”	, page 55
GF	Trailer connections.....	“”	, page 56
GF1	Diagnostics plug.....	“”	, page 57
GH1	Interior lighting L1H1/L2H1/L3H1 standard roof panel.....	“”	, page 58
GH3	Interior lighting L2H1 back area cab.....	“”	, page 59
GH5	Interior lighting L3H1 full height roof panel.....	“”	, page 60
GK	Trailer connections RIGID (Australia).....	“”	, page 61
GK1	Trailer connections TRACTOR (Australia).....	“”	, page 62
GM	Windscreen wiper washer.....	“”	, page 63
GQ	LCM/Flasher unit.....	“”	, page 64
GQ1	Horn.....	“”	, page 65
HJ	Air heater, UADR.....	“”	, page 66
HJ1	Air heater, ADR.....	“”	, page 67
HY	Climate unit.....	“”	, page 68
IA	Heated seat/buzzer belt/cigar lighter.....	“”	, page 69
IF1	Heated adjustable mirror LHD.....	“”	, page 70
IF2	Heated adjustable mirror RHD.....	“”	, page 71
IM	Central locking, immobiliser.....	“”	, page 72
IN	Theft alarm.....	“”	, page 73
IO	BBM.....	“”	, page 74
IO1_Hyb	HIOM.....	“”	, page 75
IQ	Sun roof/window lift.....	“”	, page 76
IR	12V power supply.....	“”	, page 77
IR1	12V power supply.....	“”	, page 78
IU	Radio (before w837).....	“”	, page 79
IU1	Radio (after w837).....	“”	, page 80
JB1_Hyb	24V junction box, hybrid area.....	“”	, page 81
JB2_Hyb	24V junction box, hybrid area.....	“”	, page 82
JB3_Hyb	Hybrid interface connection.....	“”	, page 83
JB4_Hyb	Hybrid interface connection.....	“”	, page 84

JB5_Hyb	Ground bar/radiators and grid, hybrid area	“” , page 85
KA	Cab tilt and brake body builder output/horameter	“” , page 86
NA	Body builder connector PB1.....	“” , page 87
NB	Body builder connector PB2.....	“” , page 88
NC	Body builder connector PB3.....	“” , page 89
ND	Body builder connector PB4.....	“” , page 90
NE	Body builder connector PB5.....	“” , page 91
XA	Bus J1708/J1587	“” , page 92
XB	Bus J1939-1	“” , page 93
XC	Bus J1939-2	“” , page 94
XD	Bus J1939-7	“” , page 95

Component wiring diagrams

WIRING DIAGRAM AA

Power supply, starting system, UADR

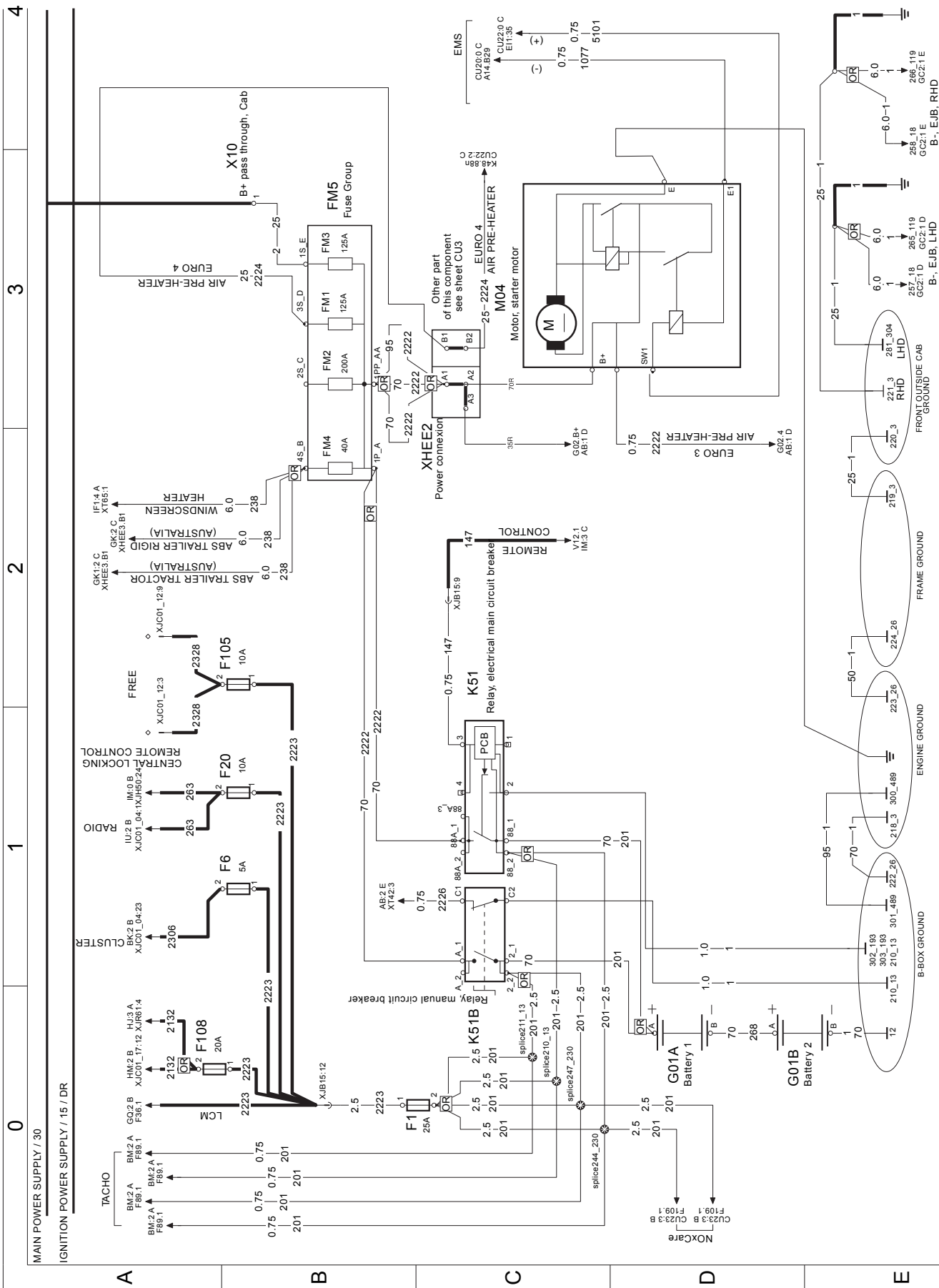

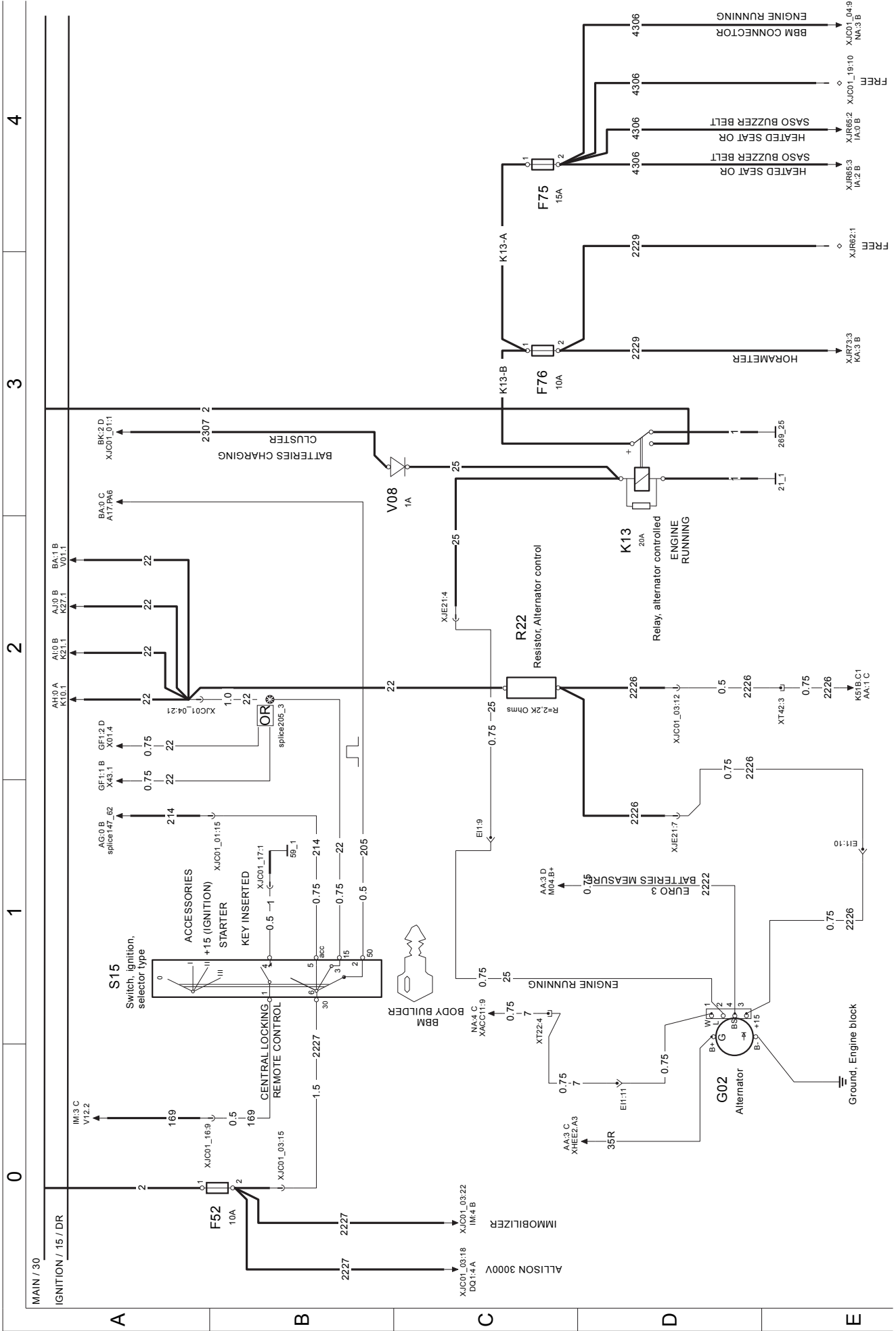

Power supply distribution

WIRING DIAGRAM AB_Hyb

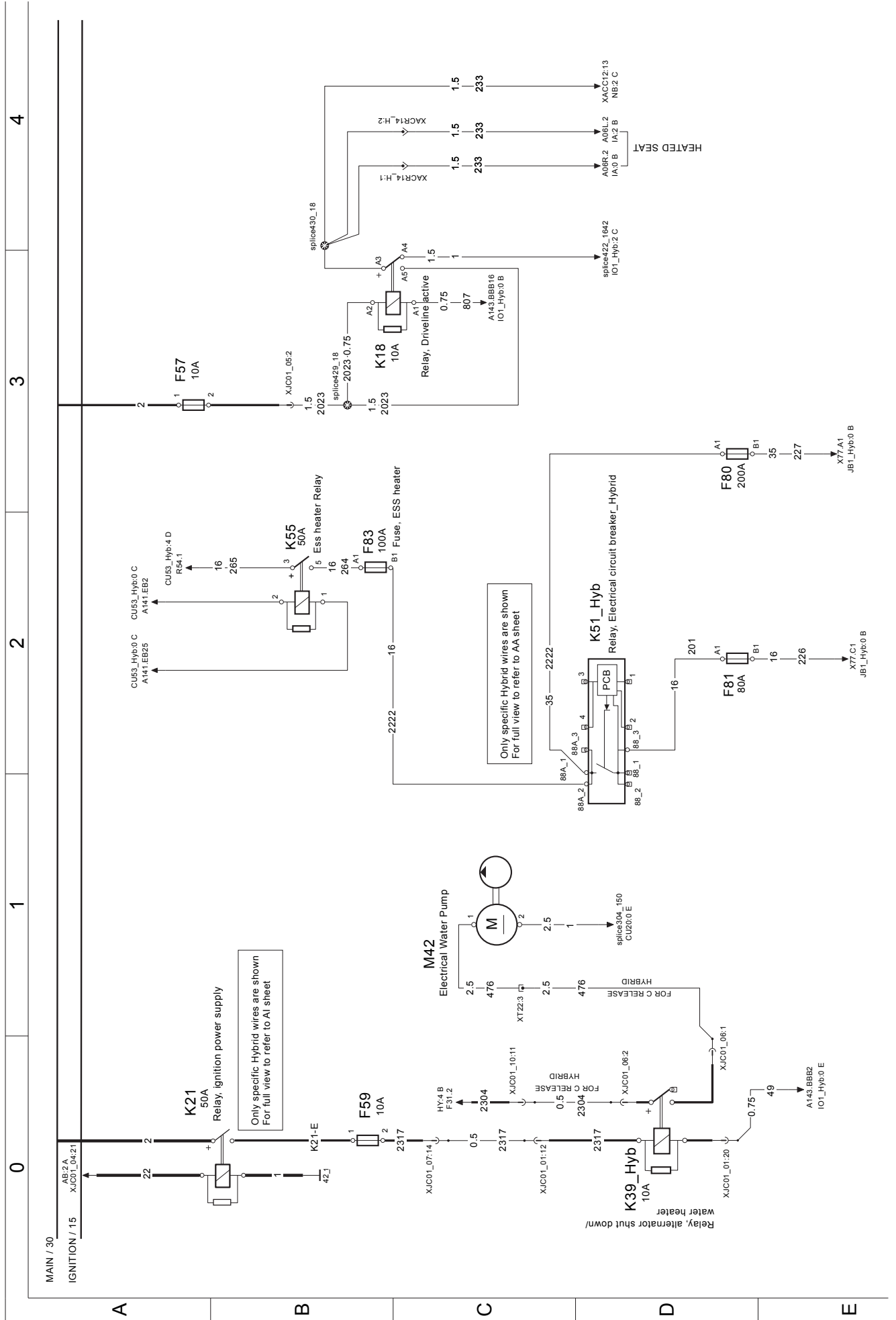

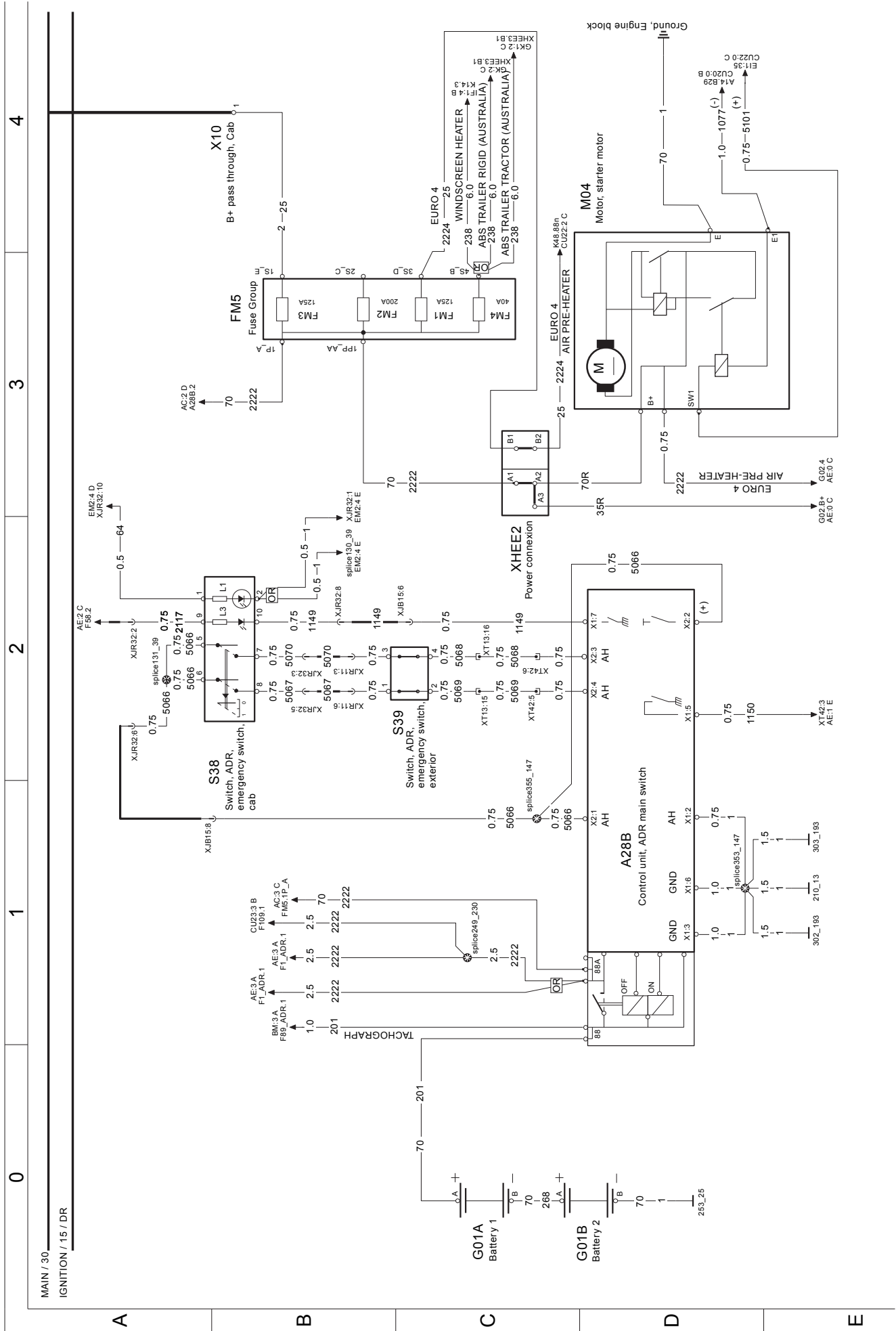

Power distribution, ADR

WIRING DIAGRAM AE

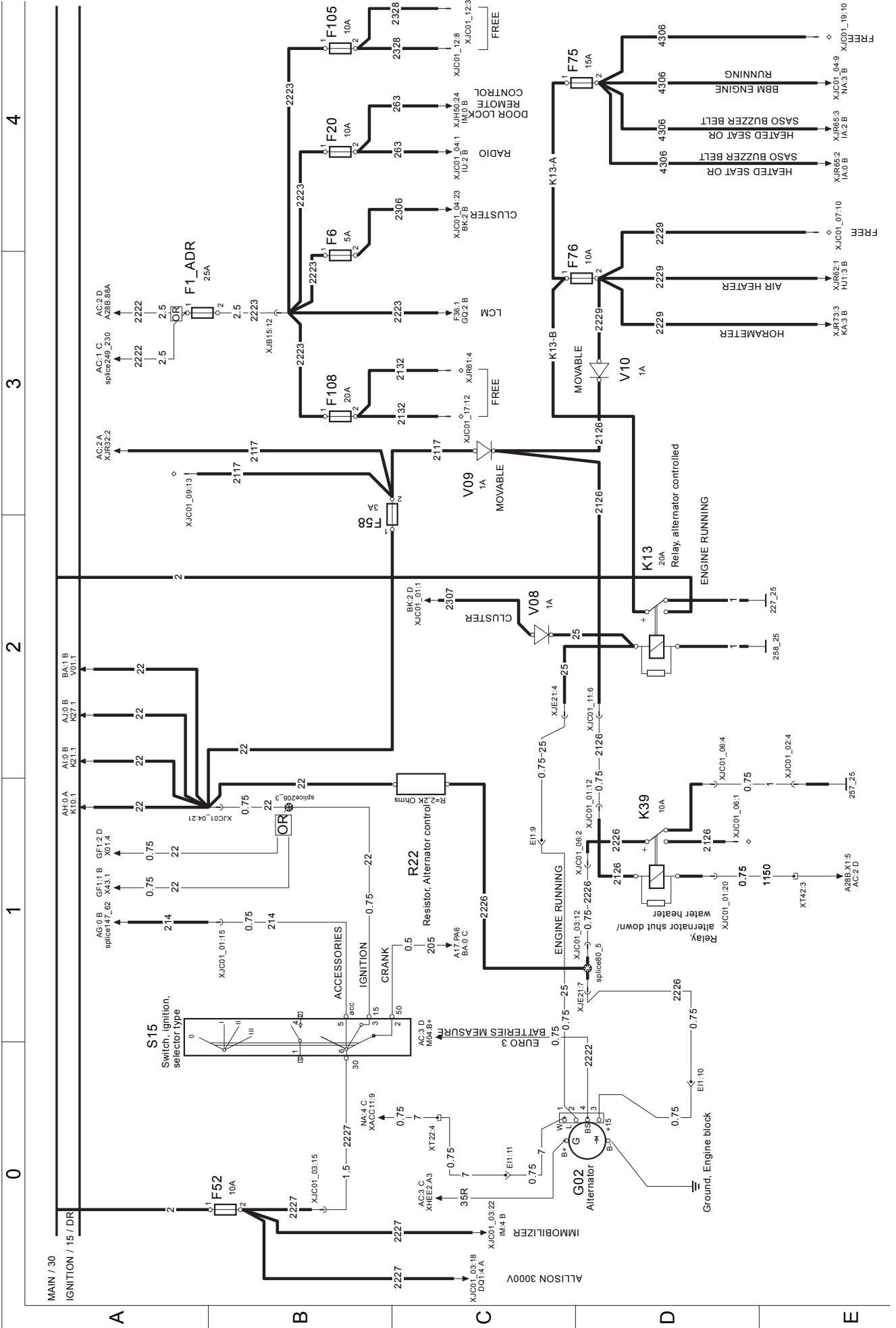

Accessories power supply

WIRING DIAGRAM AG

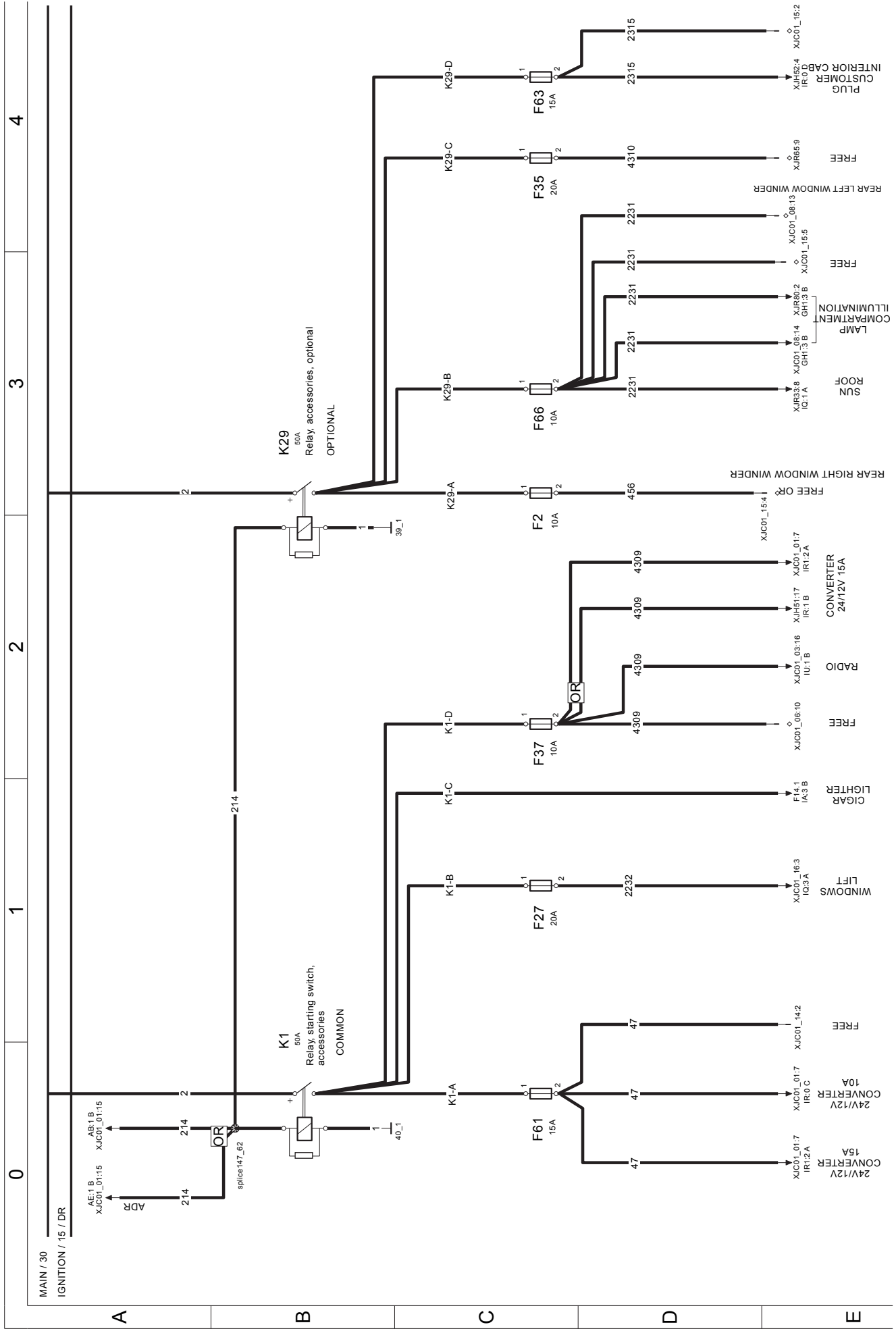

WIRING DIAGRAM AH

Power supply, kl.15, relay K10

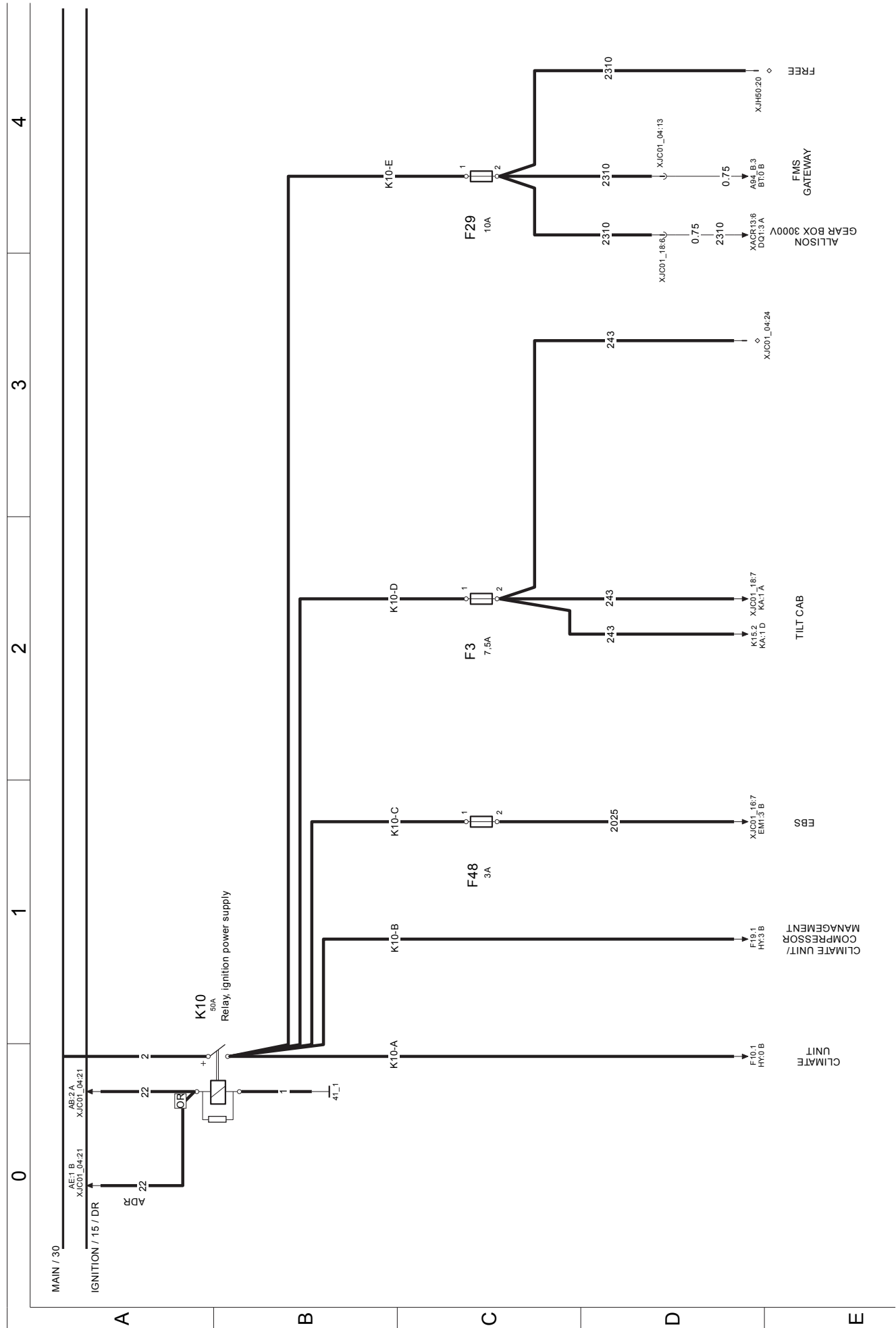

Power supply, kl.15, relay K21

WIRING DIAGRAM AI

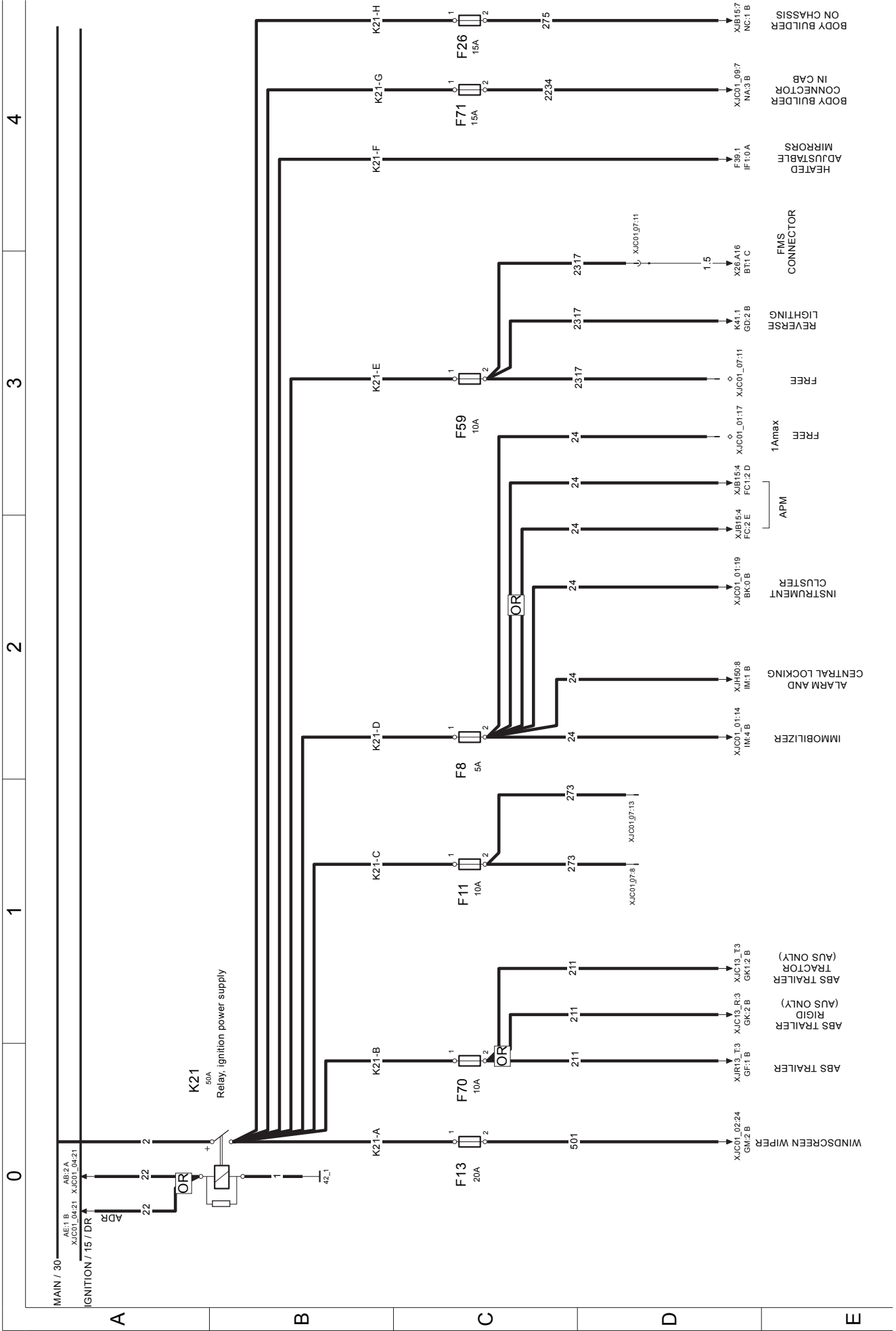

Power supply, kl.15, relay K27

WIRING DIAGRAM AJ

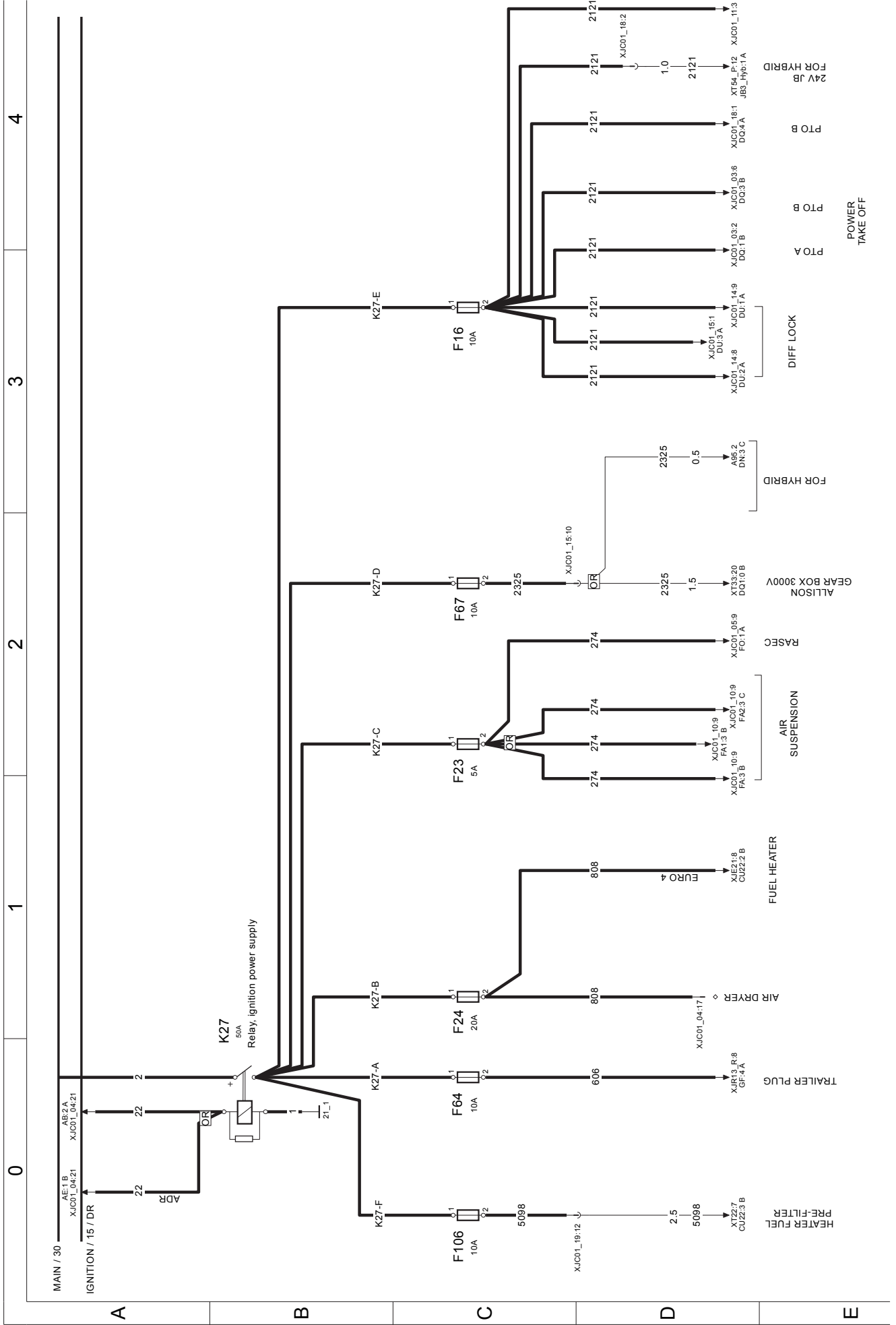

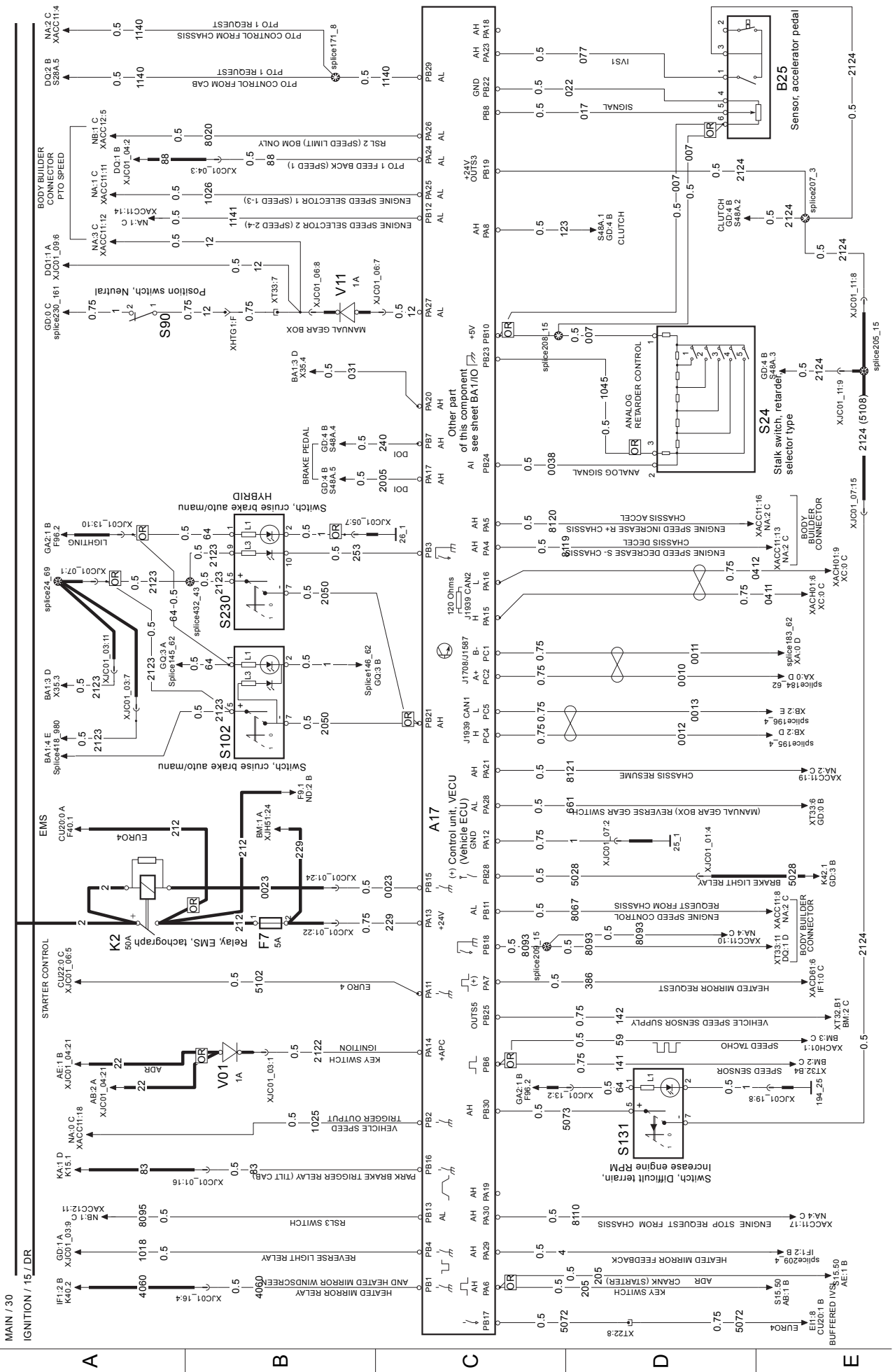

0 1 2 3 4

MAIN / 30
IGNITION / 15 / DR

Other part
of this component
see sheets BA1 / O

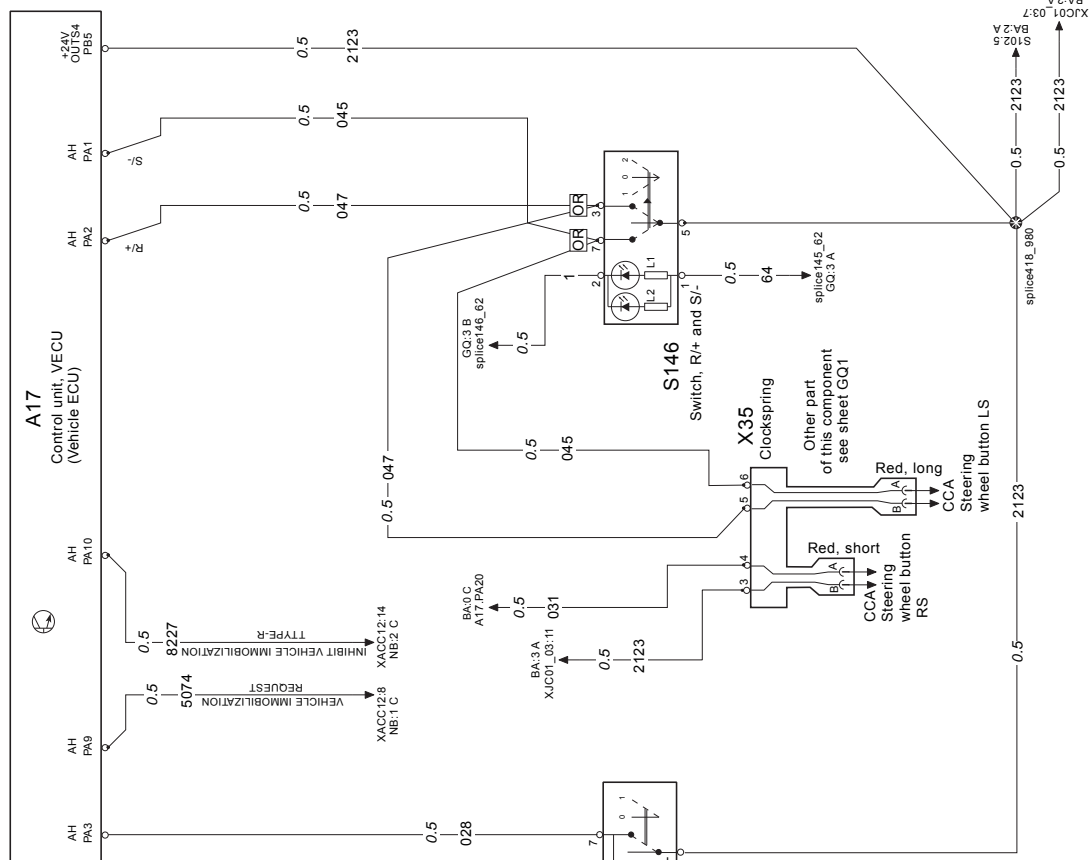

MAIN / 30
IGNITION / 15 / DR

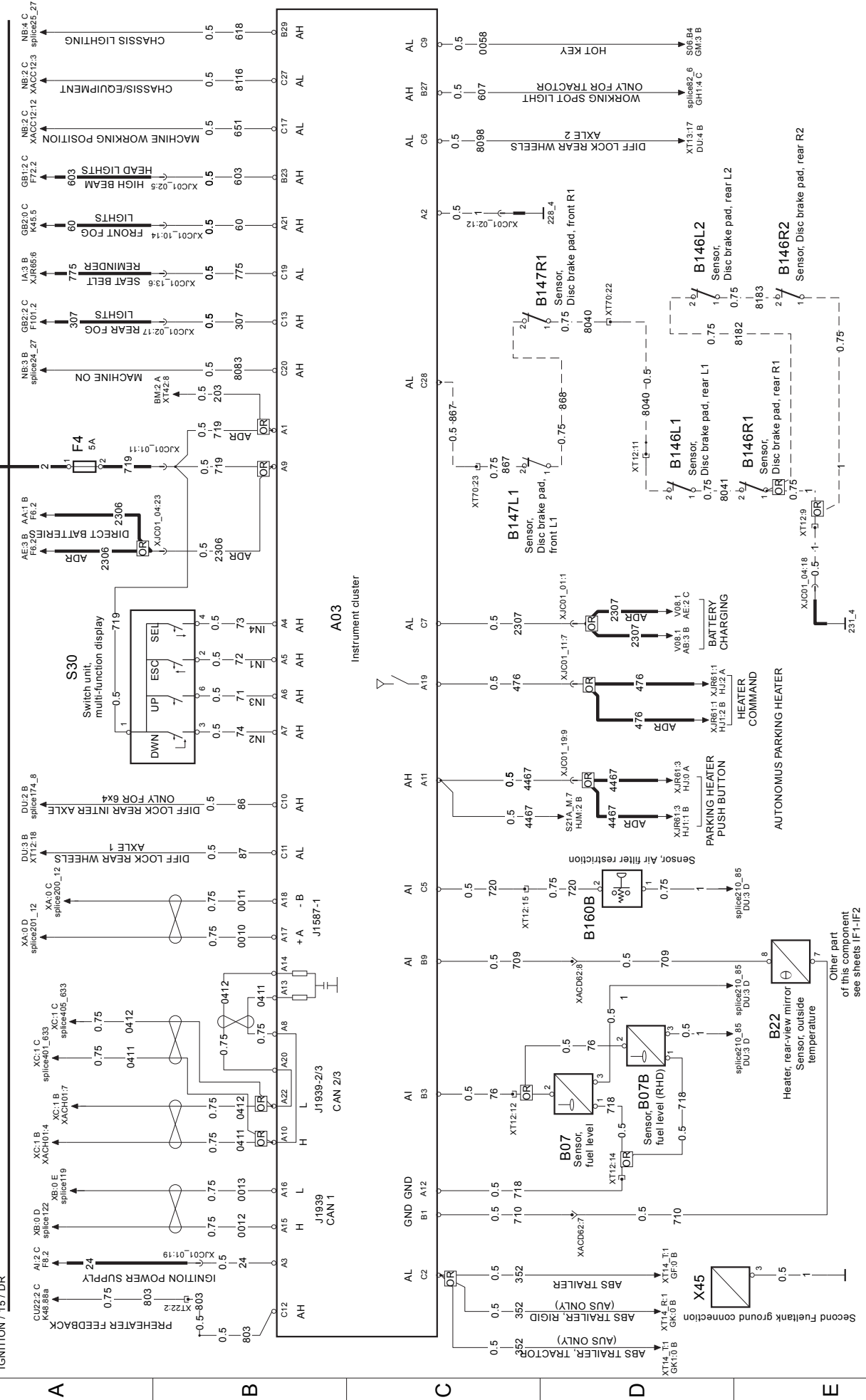

Tachograph

WIRING DIAGRAM BM

0

1

2

3

4

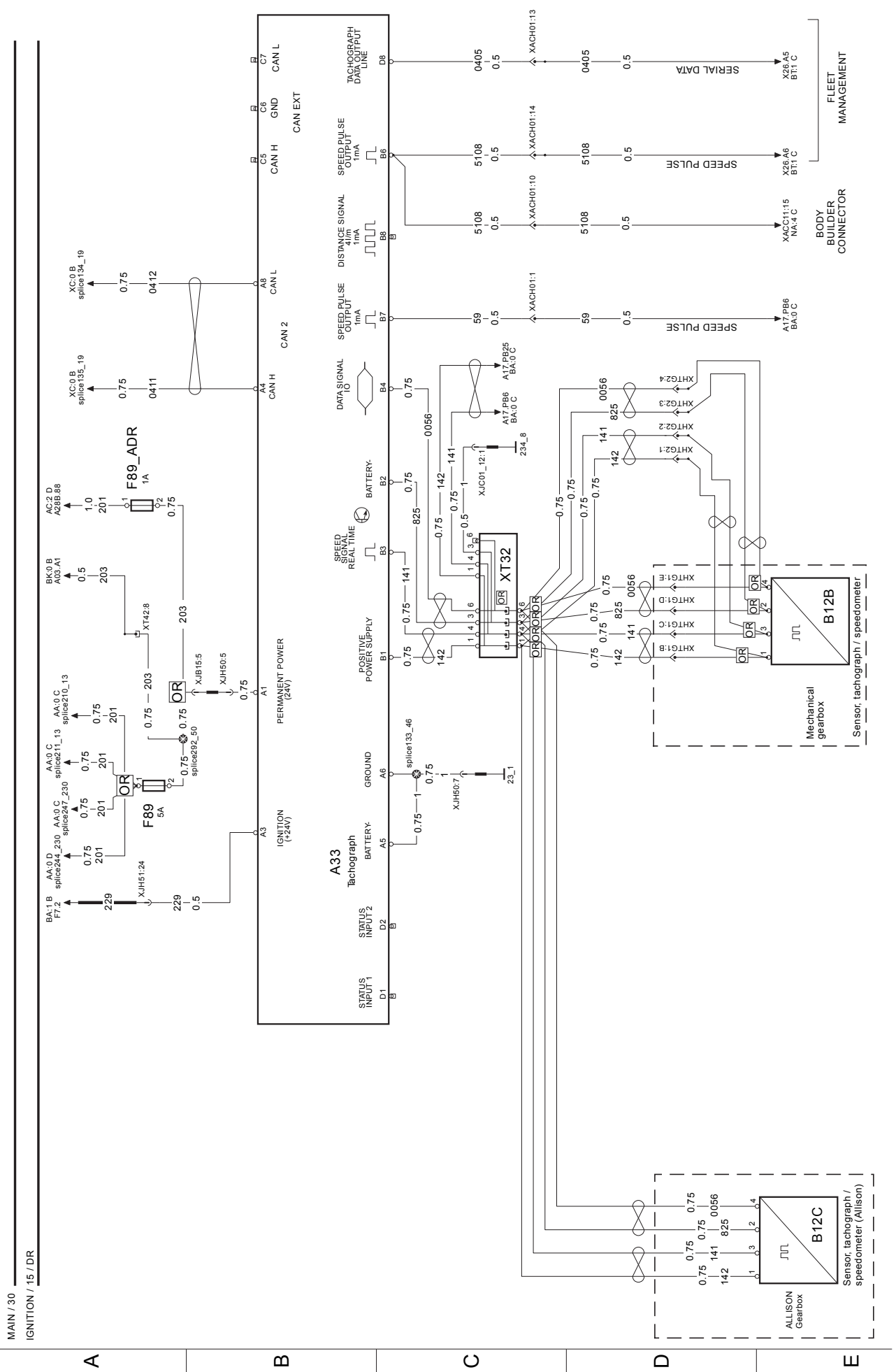

Feet management system Gateway (FMS)

WIRING DIAGRAM BT

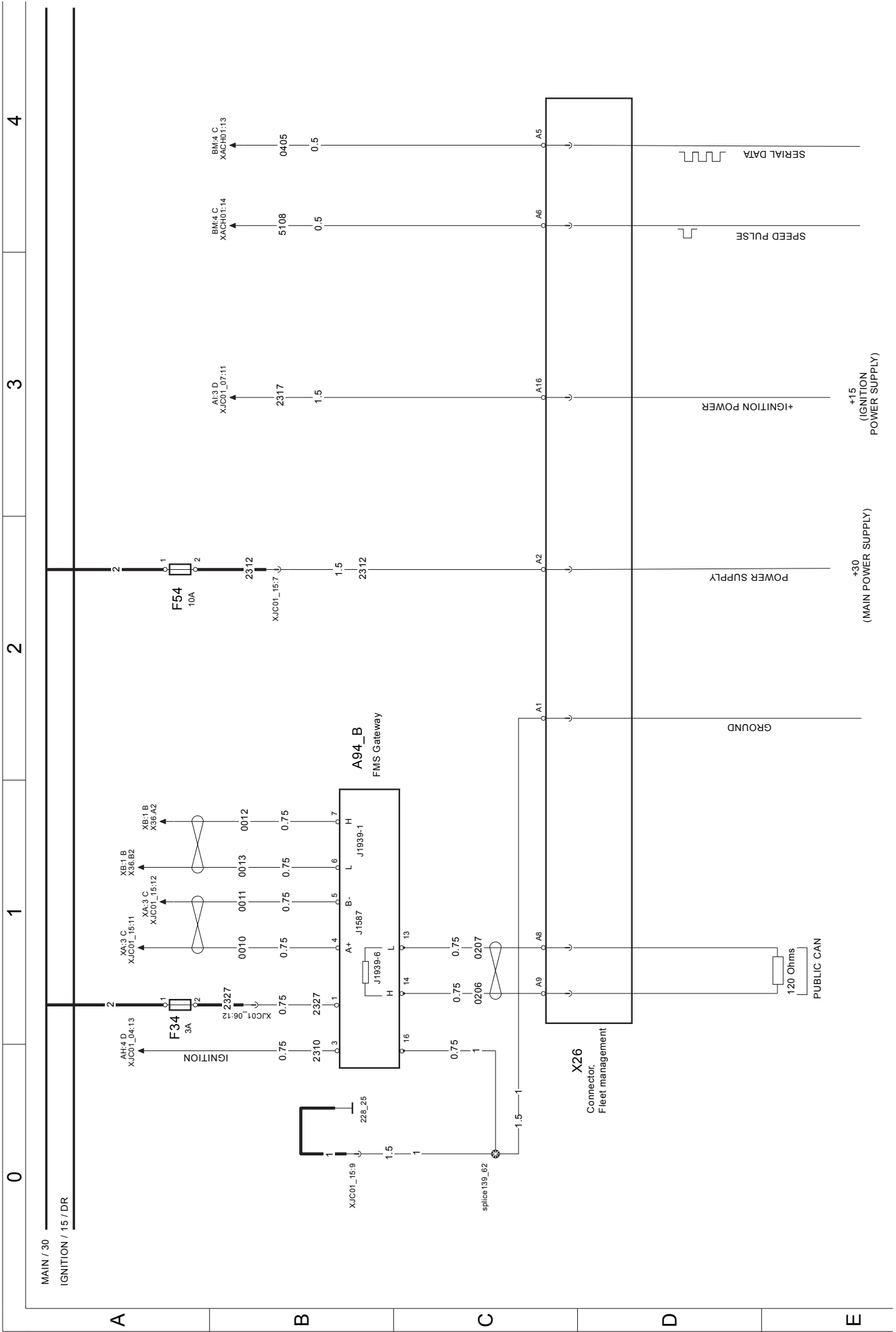

Engine ECU (B connector)

WIRING DIAGRAM CU20

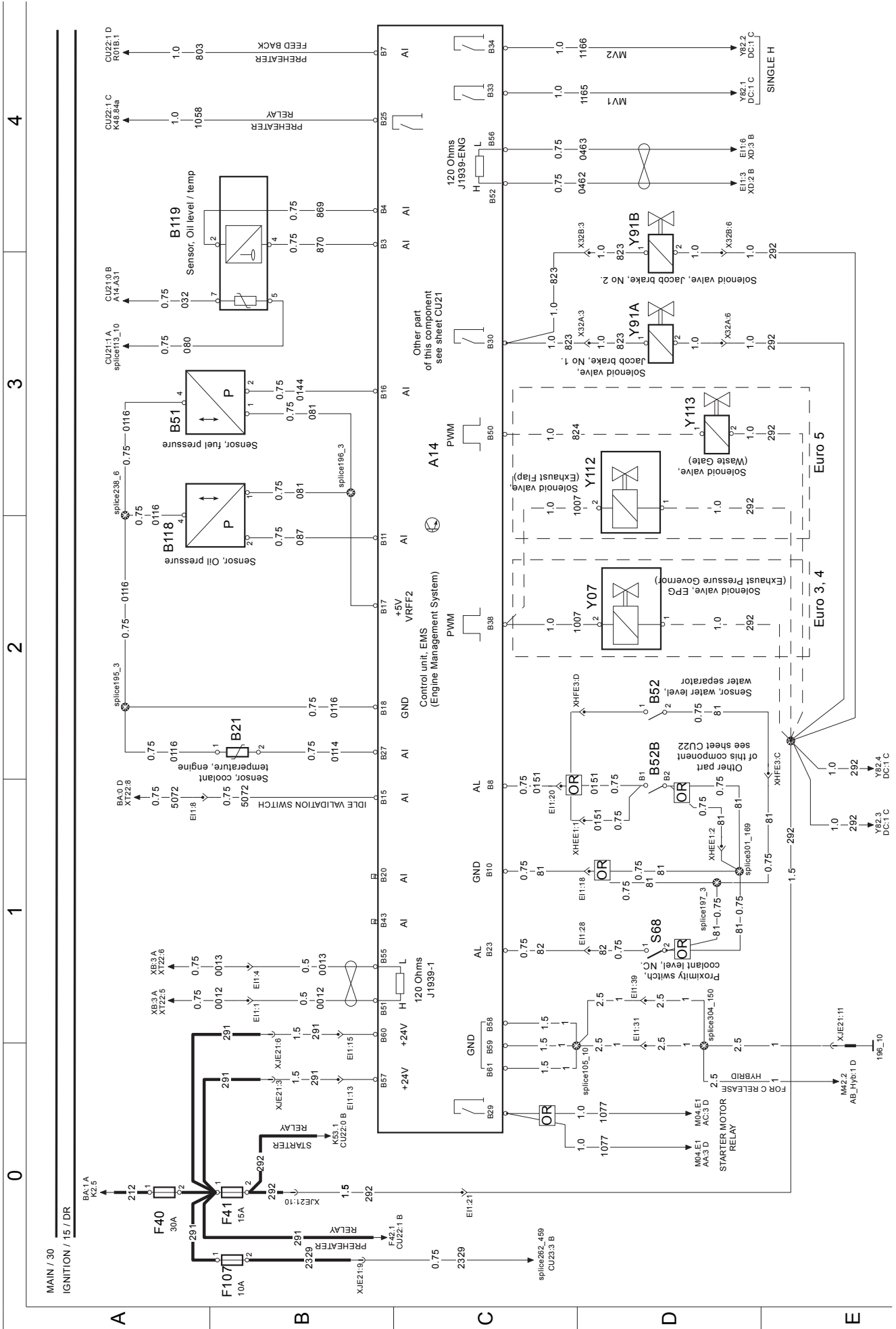

0

1

2

3

4

MAIN / 30

IGNITION / 15 / DR

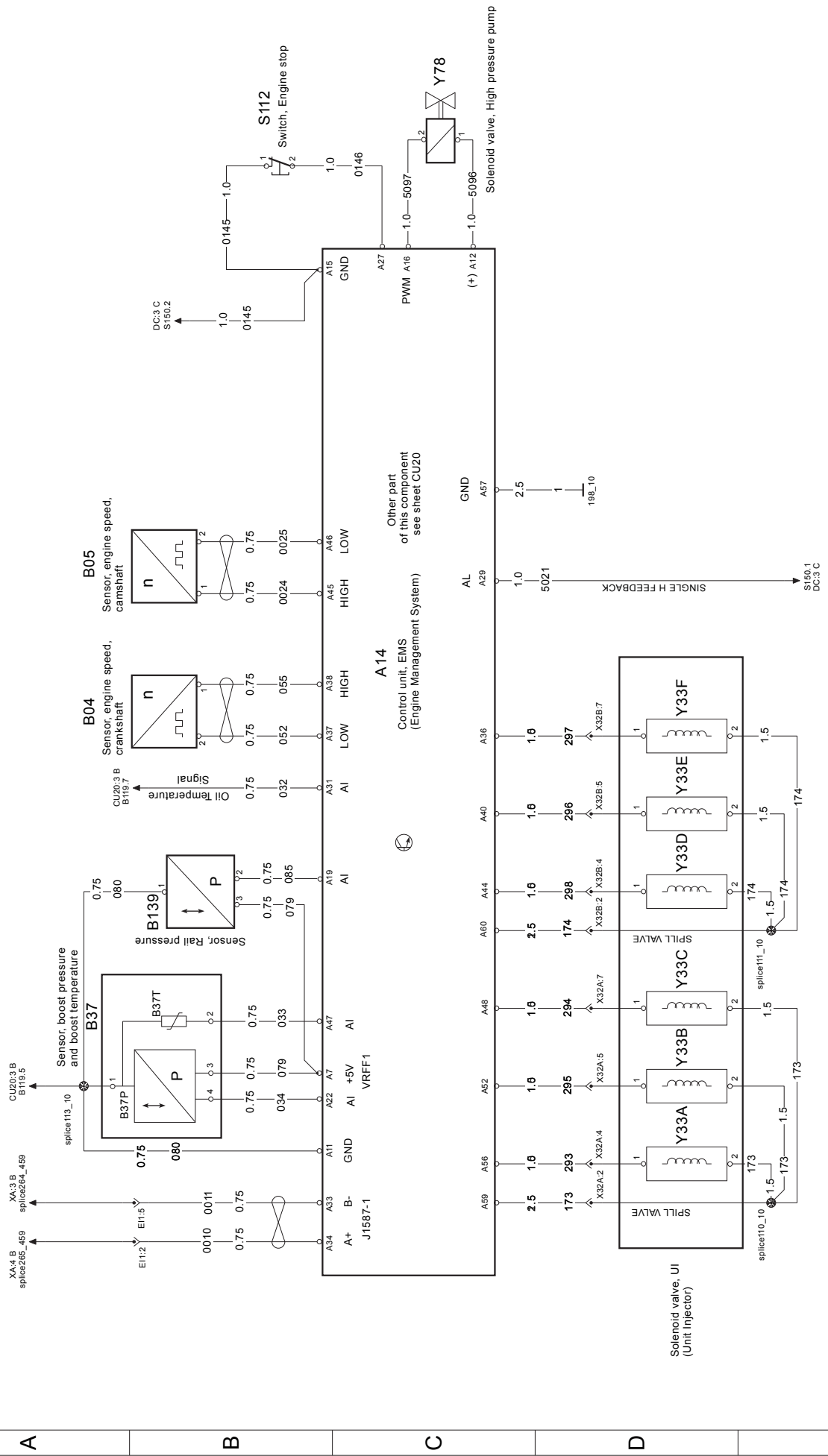

Engine air preheater, fuel heater

WIRING DIAGRAM CU22

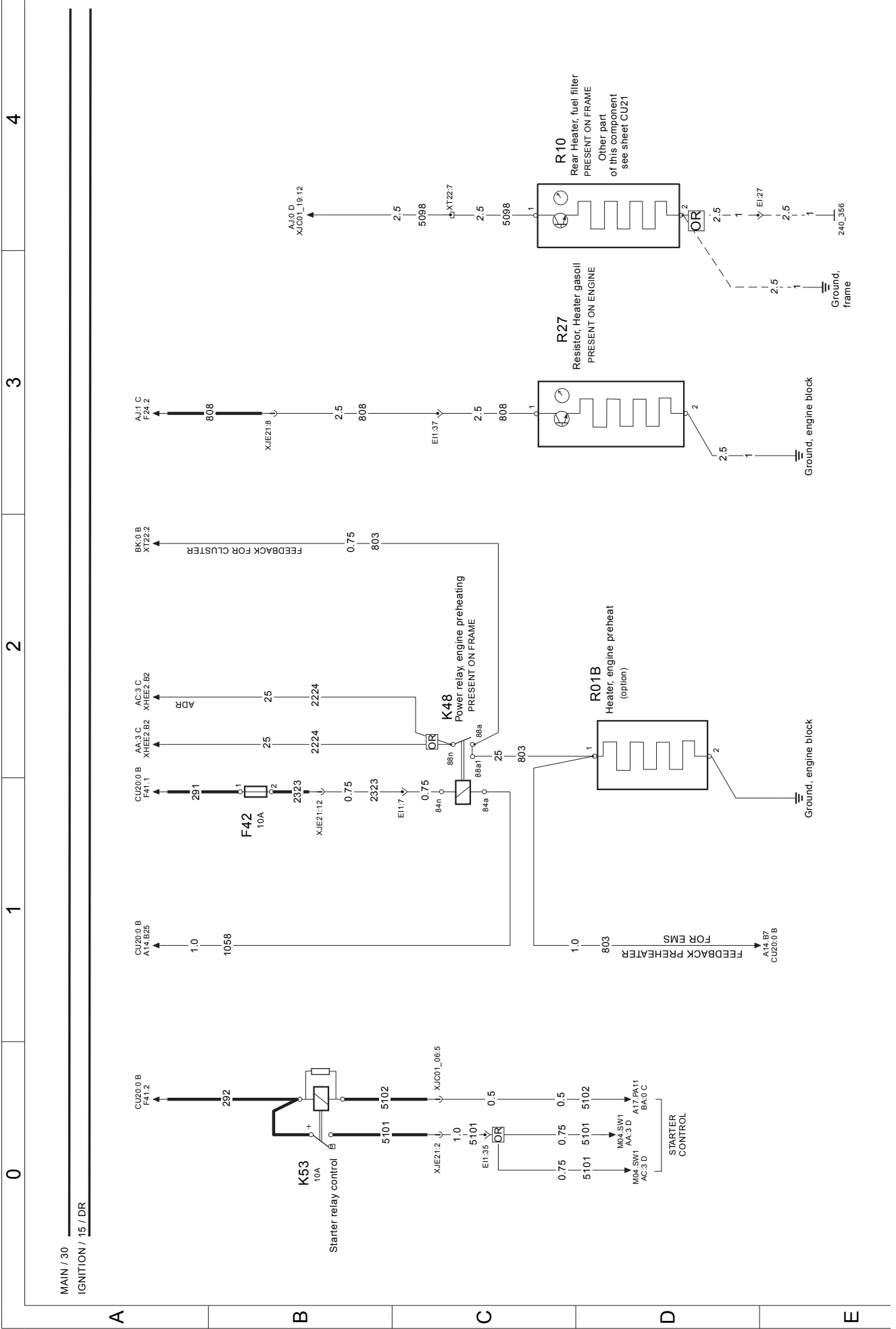



MAIN / 30
IGNITION / 15 / DR

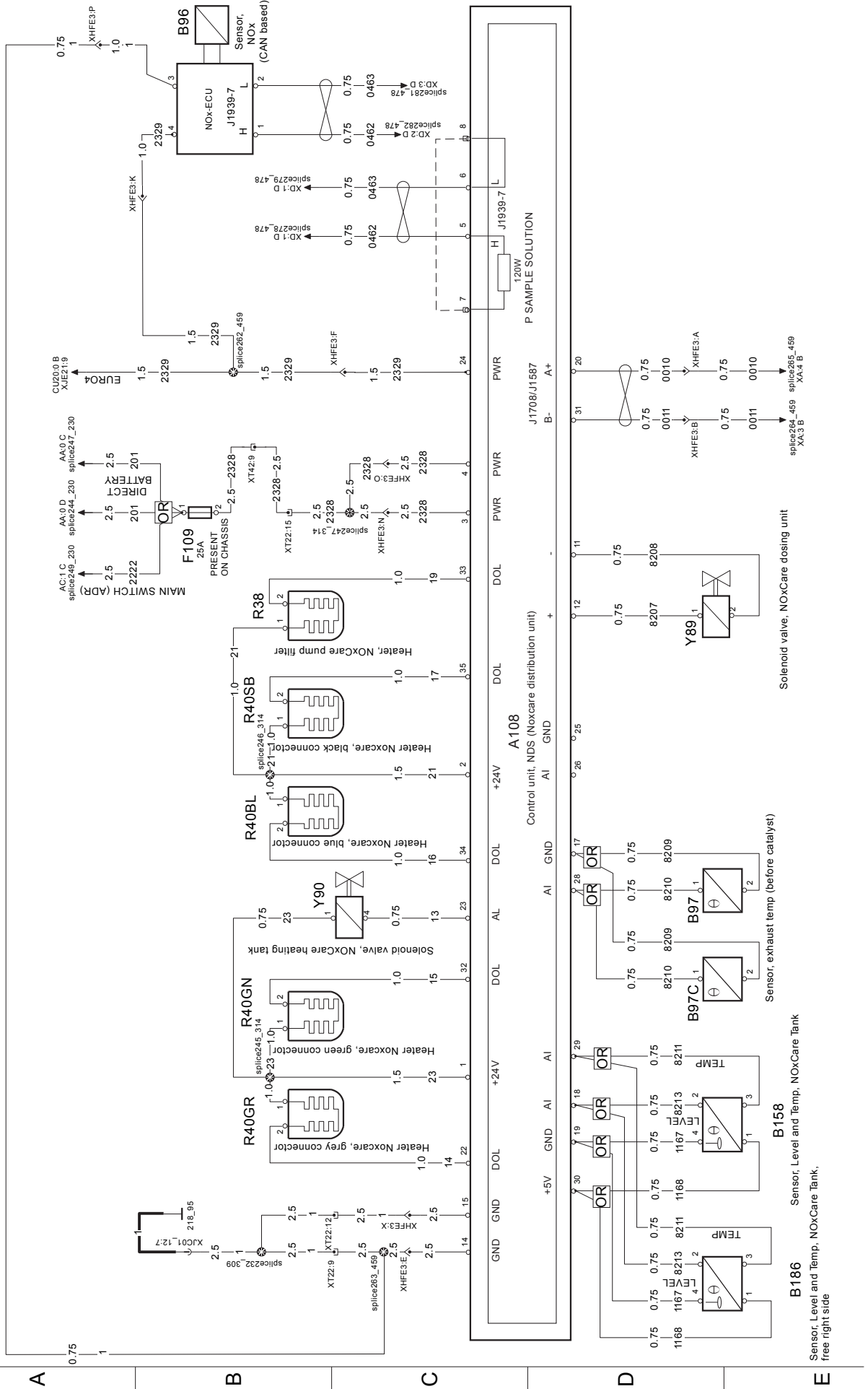

MAIN / 30
IGNITION / 15

A

B

C

D

E

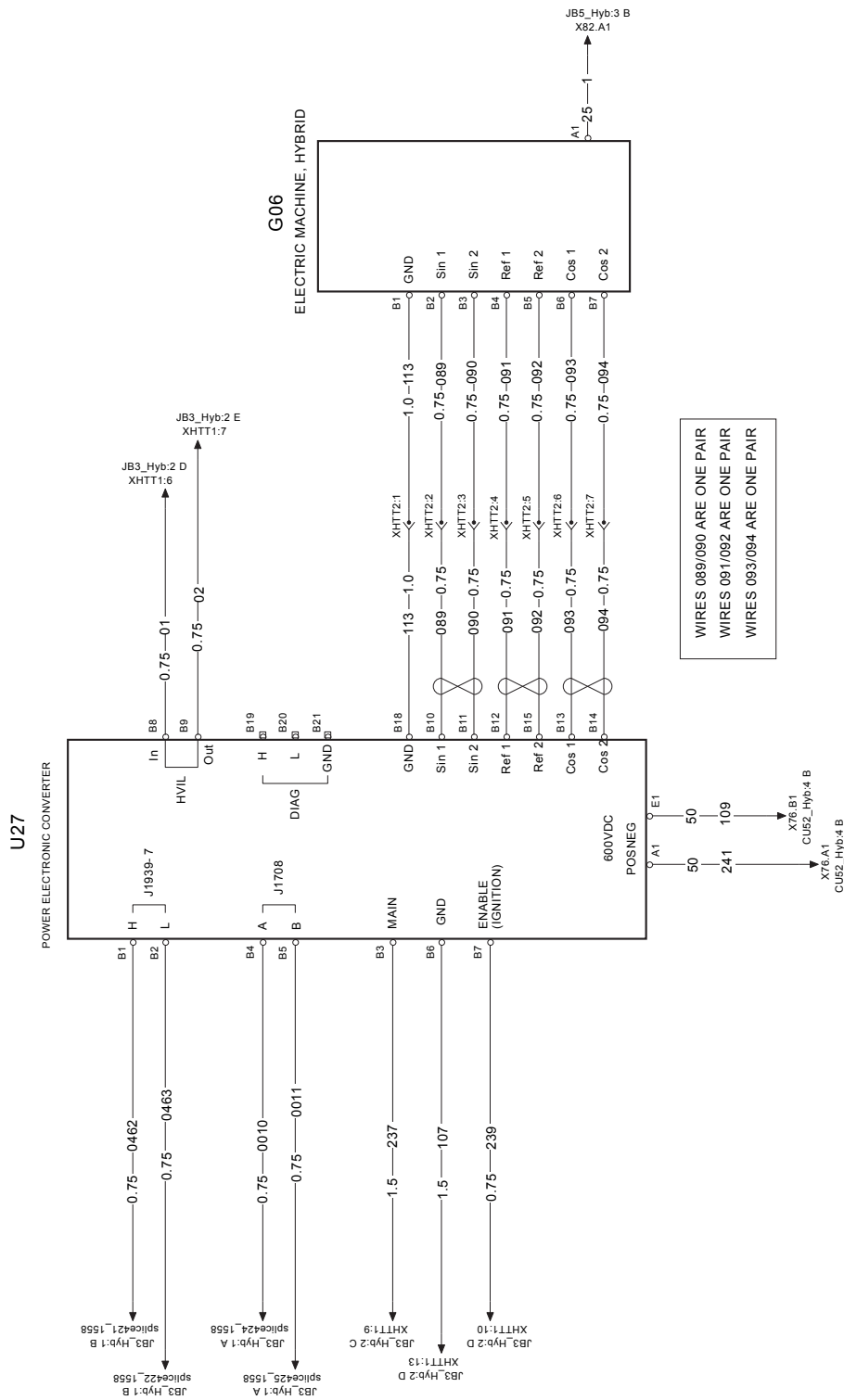

0

1

2

3

4

MAIN / 30
IGNITION / 15

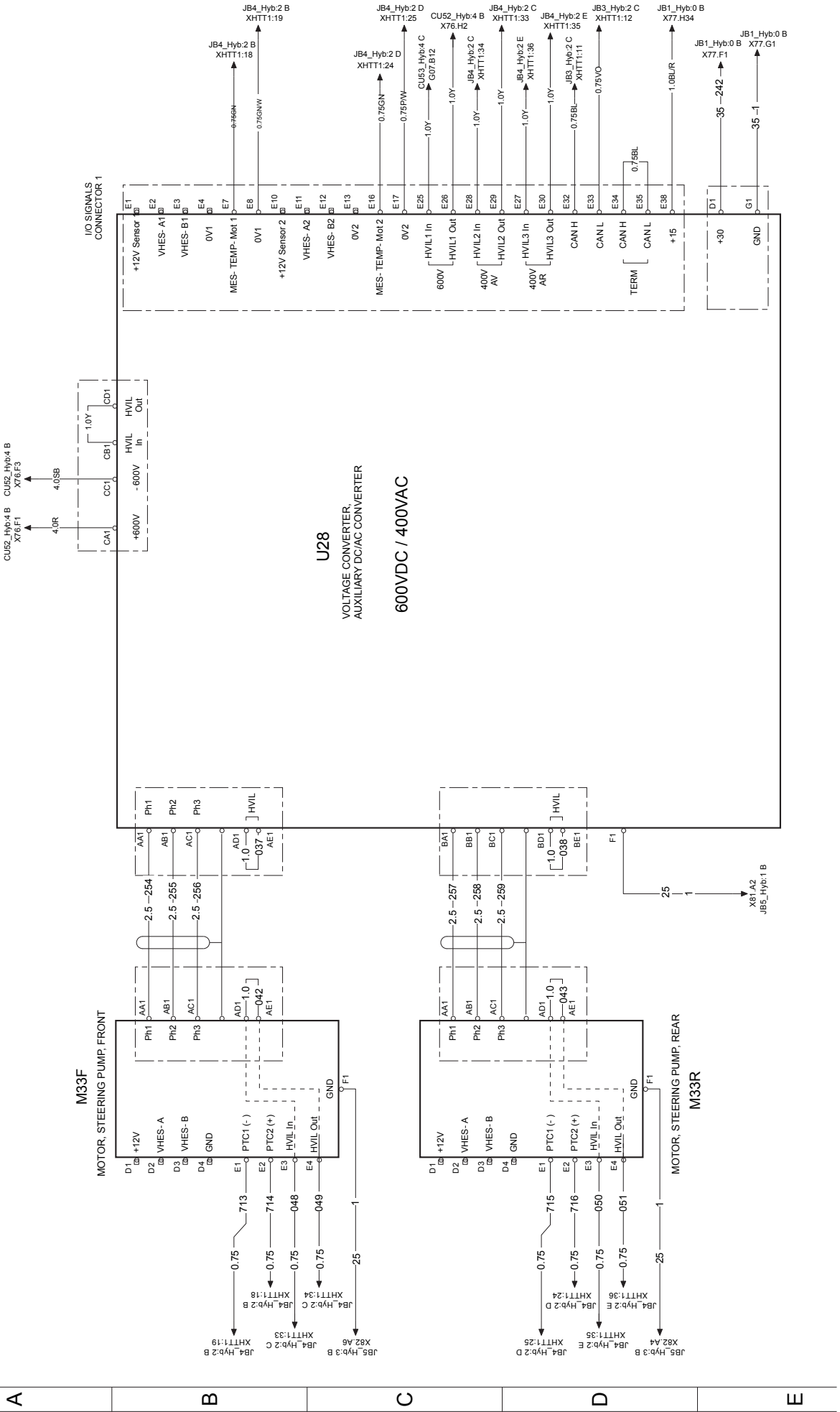

WIRING DIAGRAM CU52_Hyb

600V DC/24V DC HVJB Hybrid Area

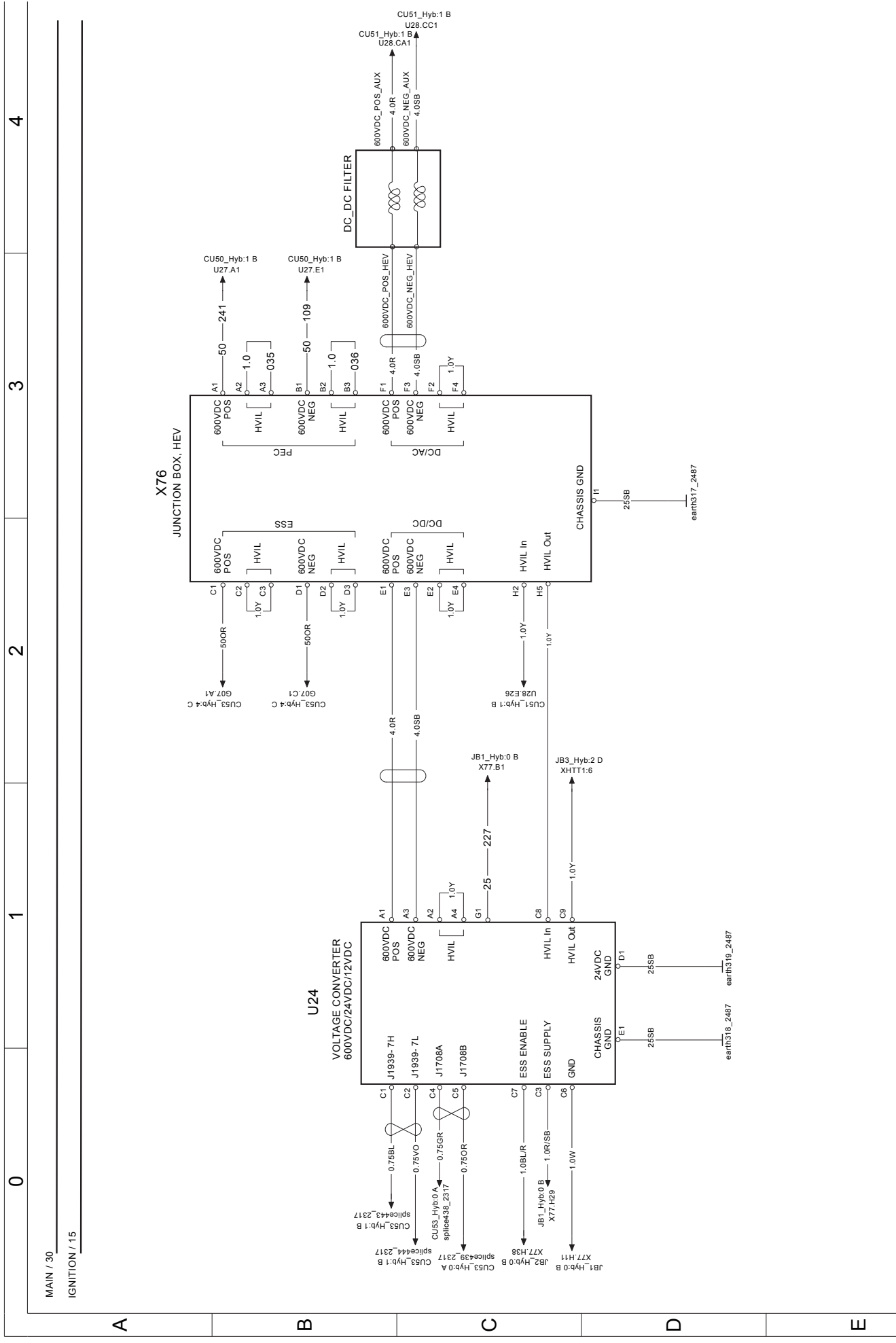

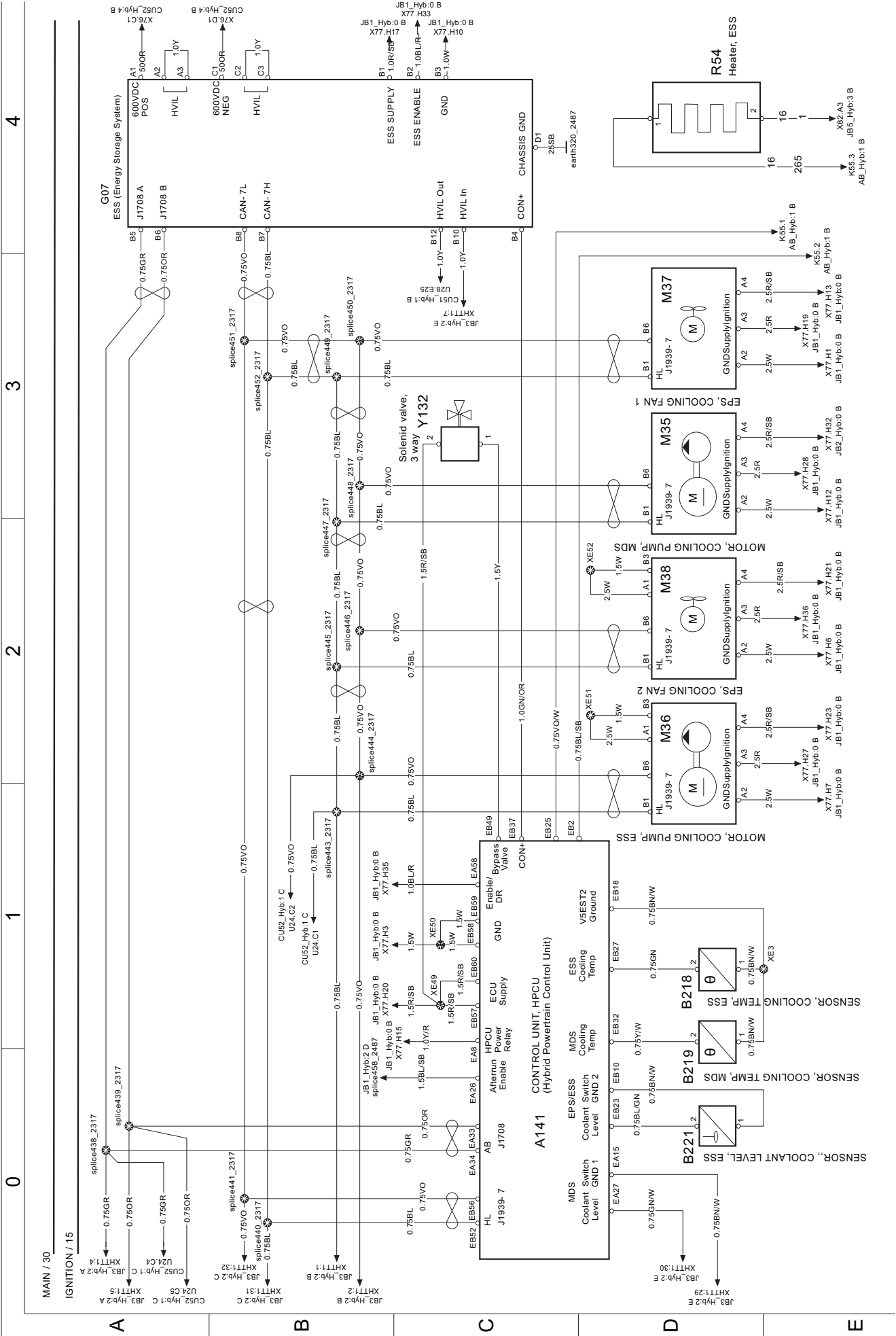

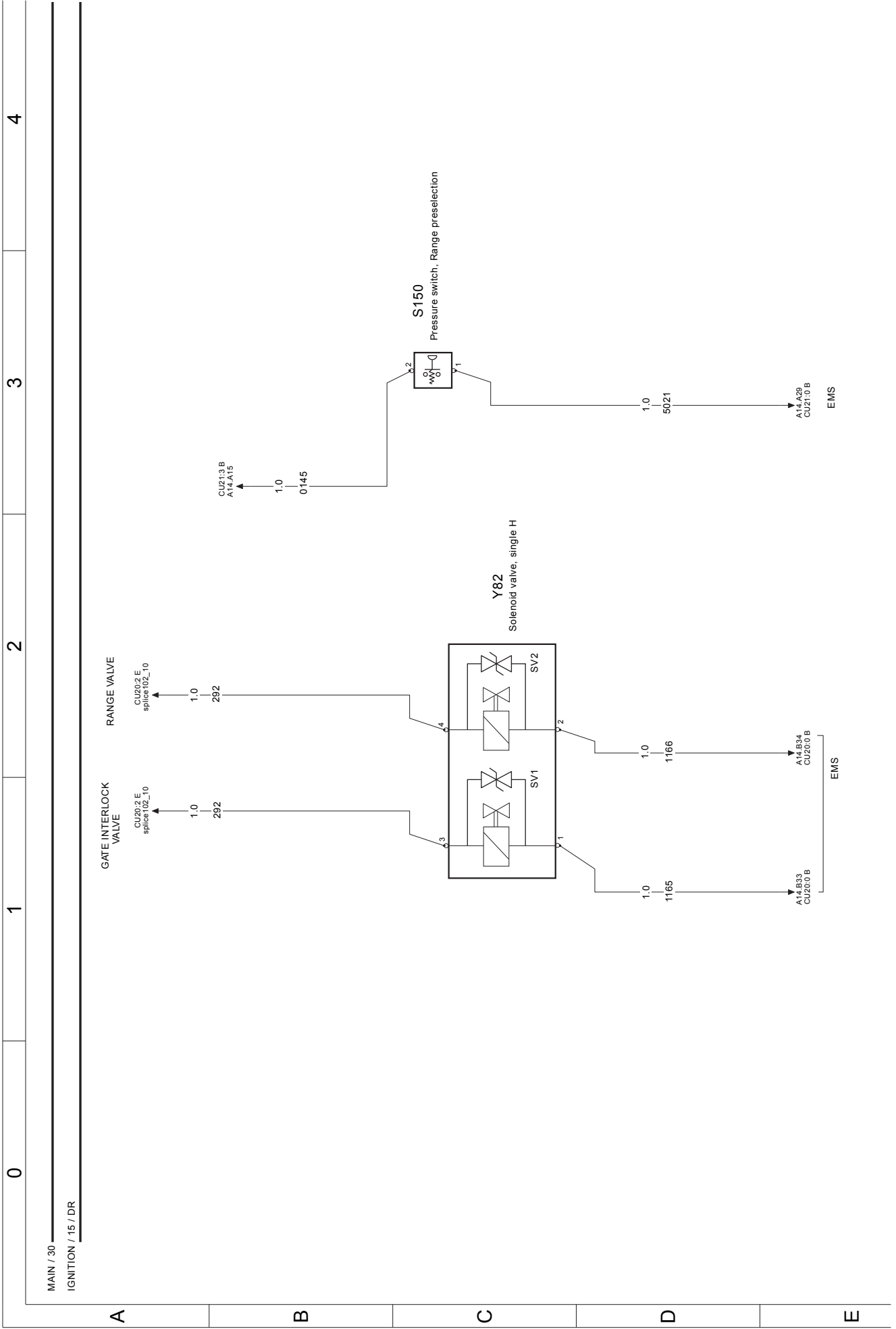

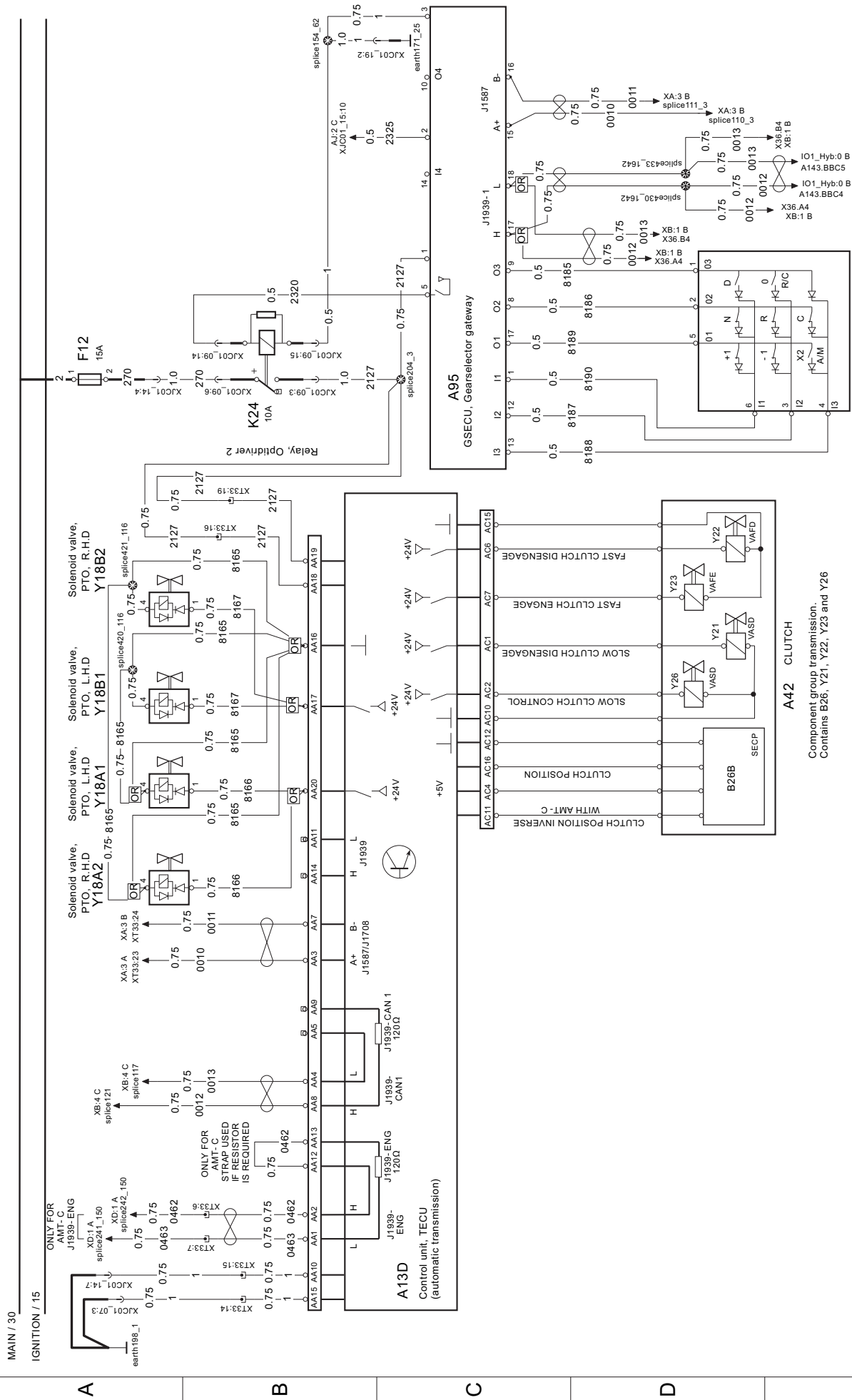

Power take off

WIRING DIAGRAM DQ

0 1 2 3 4

MAIN / 30
IGNITION / 15 / DR

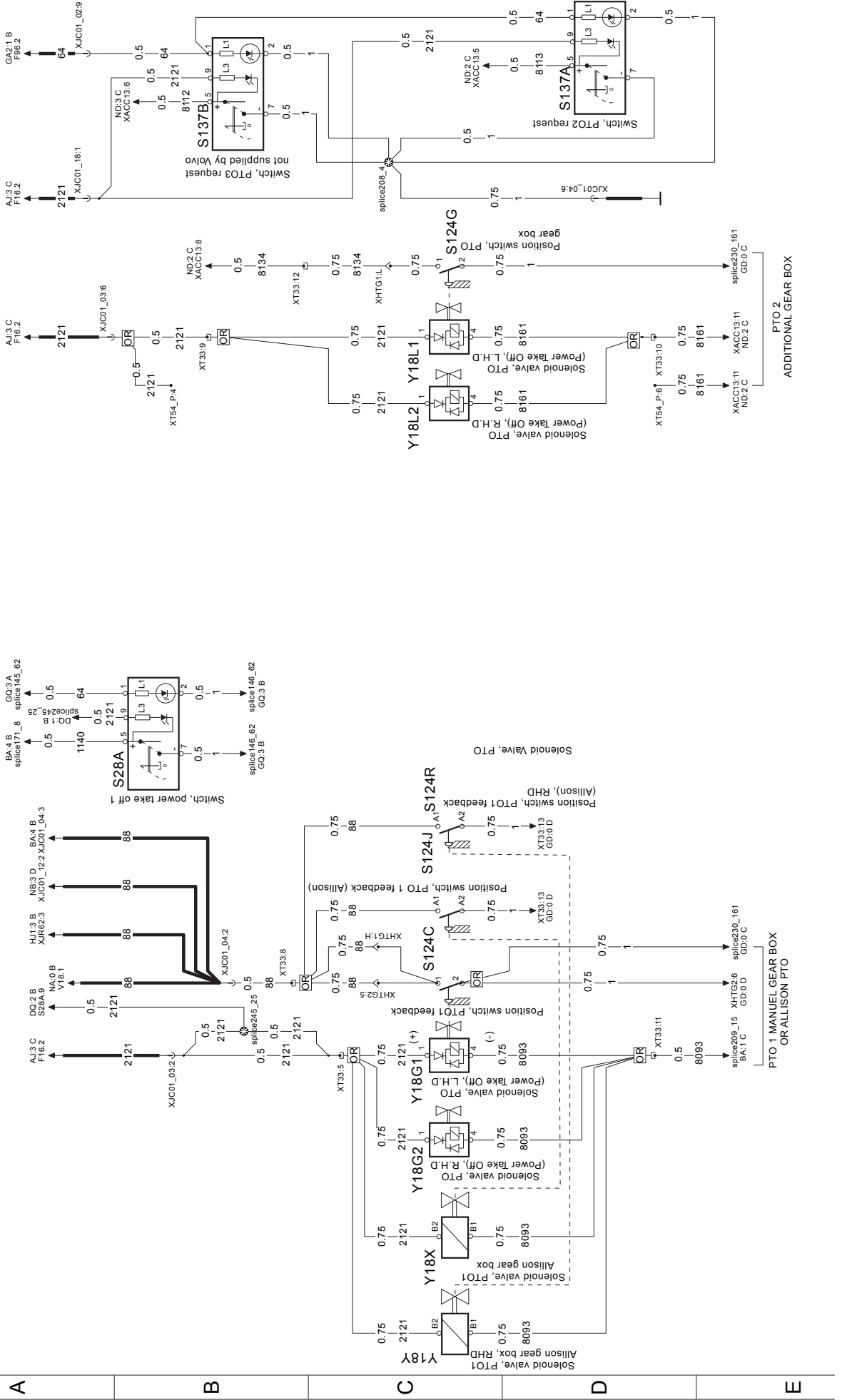

0 1 2 3 4

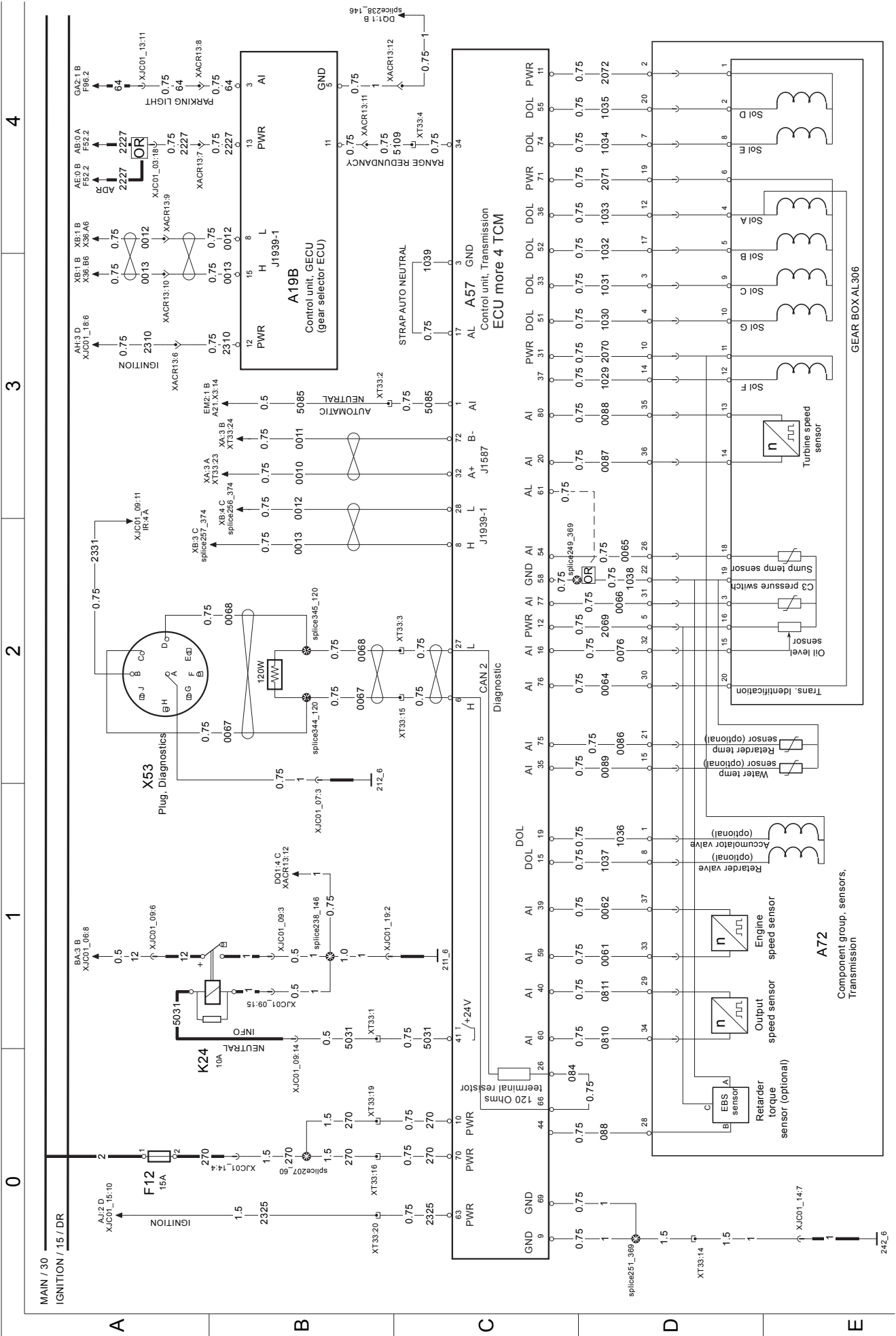

4

3

2

1

0

MAIN / 30

IGNITION / 15 / DR

A

B

C

D

E

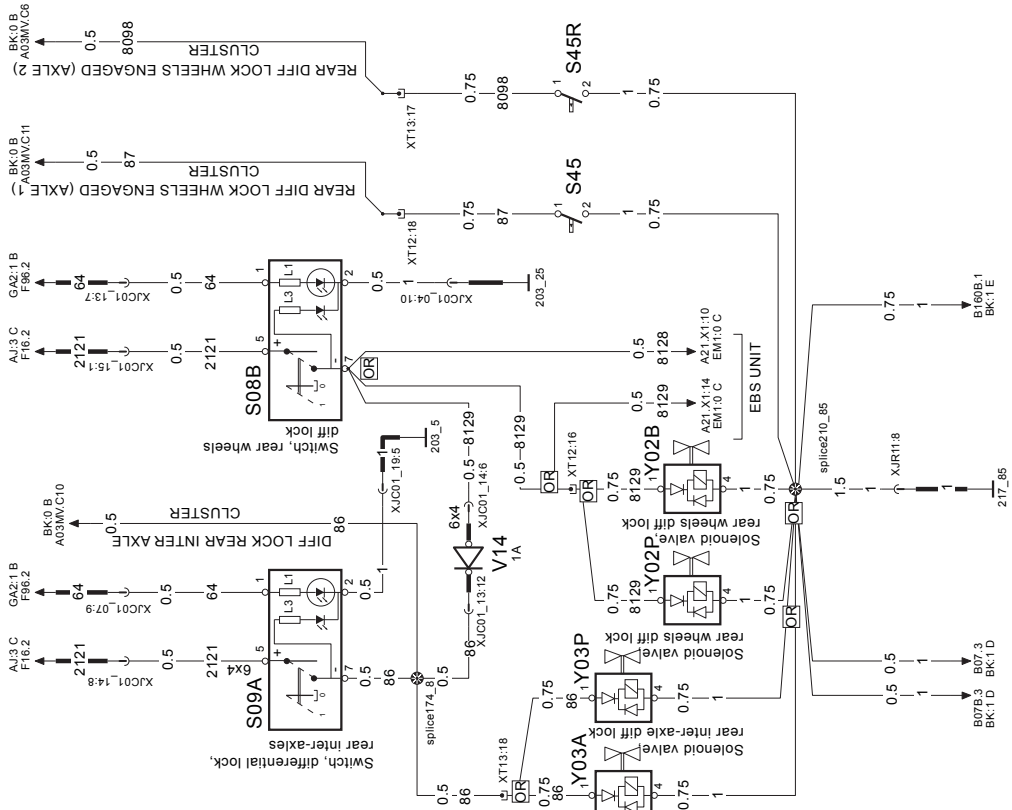

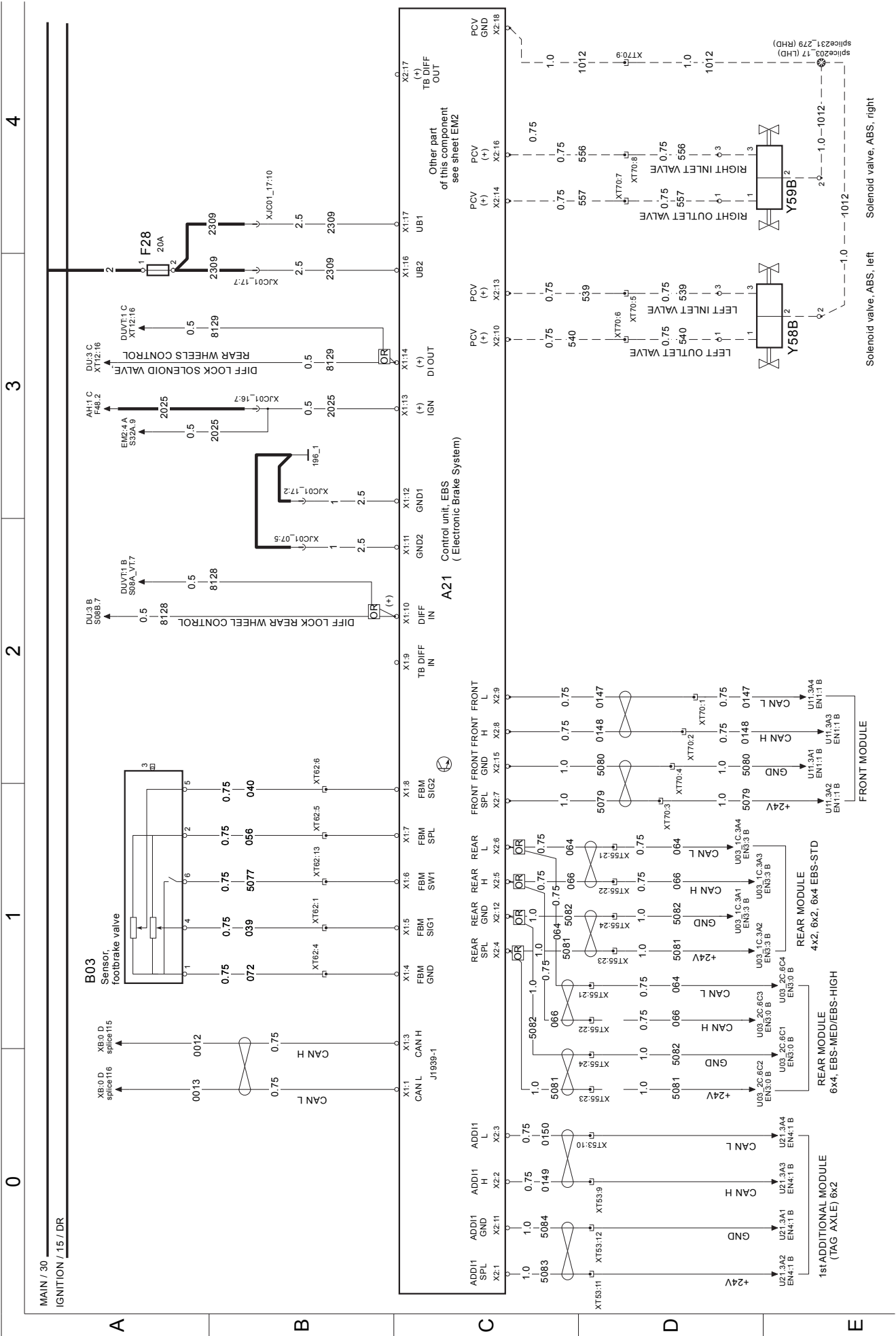

EBS ECU, connector X3/X4

WIRING DIAGRAM EM2

0

1

2

3

4

MAIN / 30
IGNITION / 15 / DR

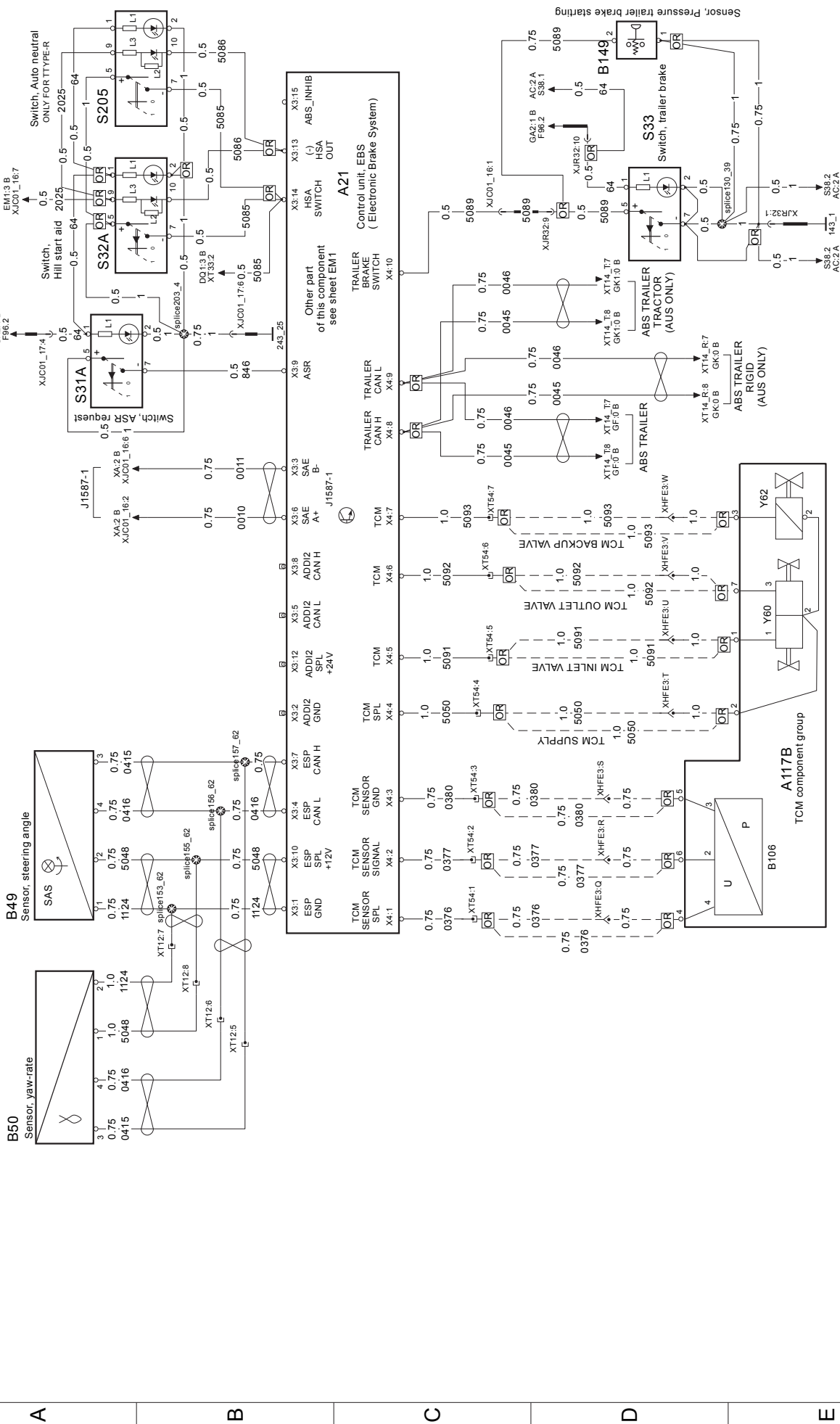

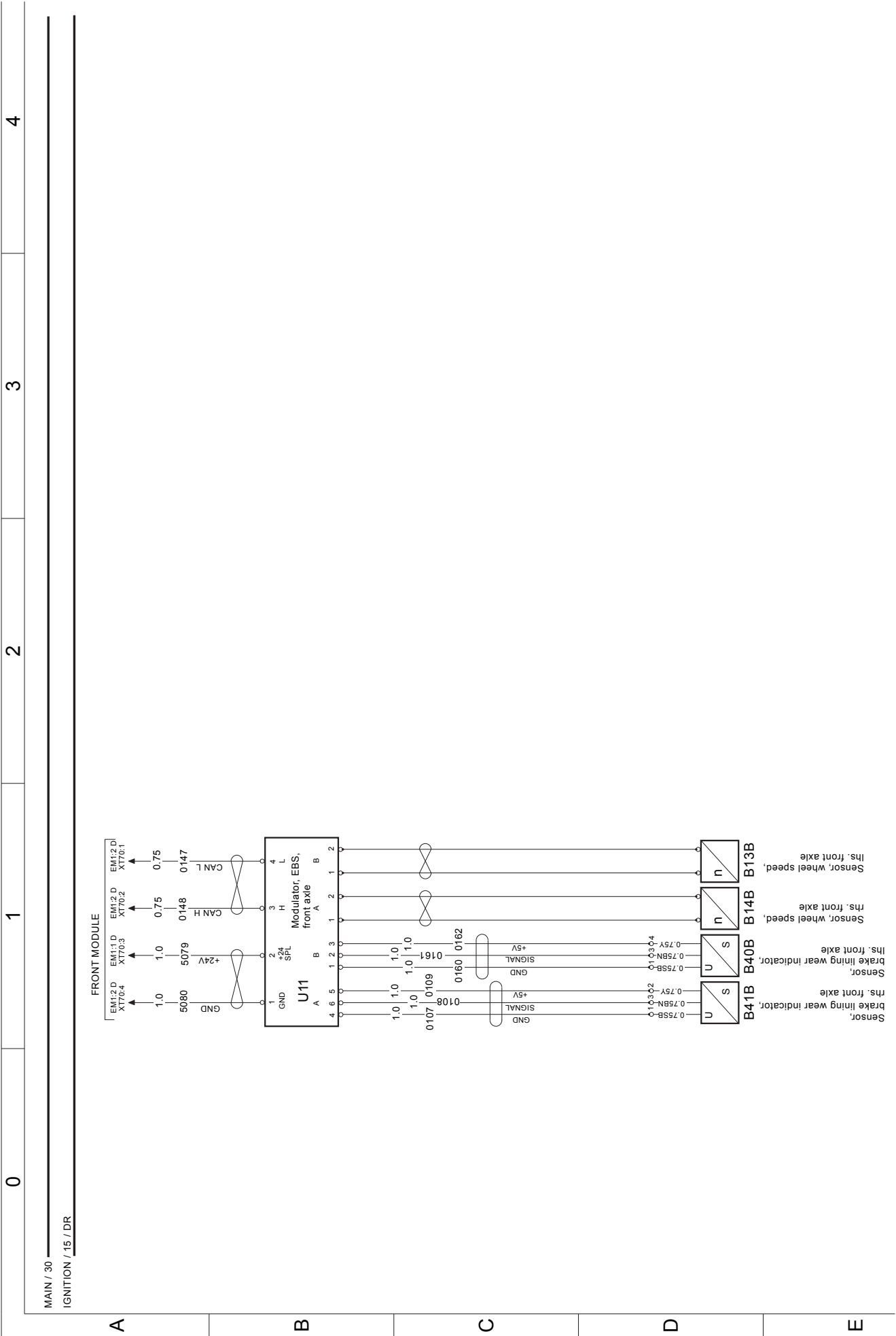

EBS rear modulators (drive axle)

WIRING DIAGRAM EN3

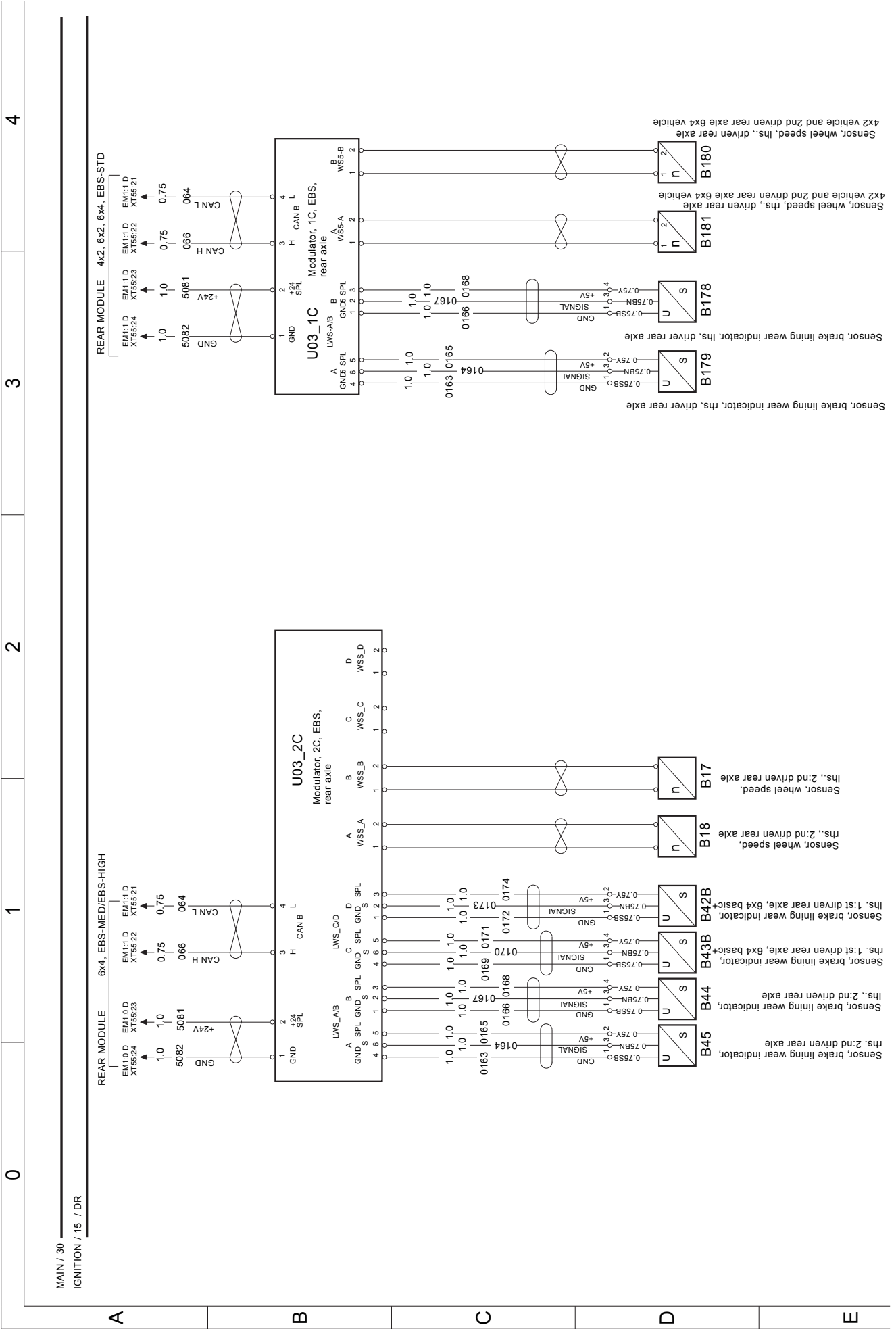

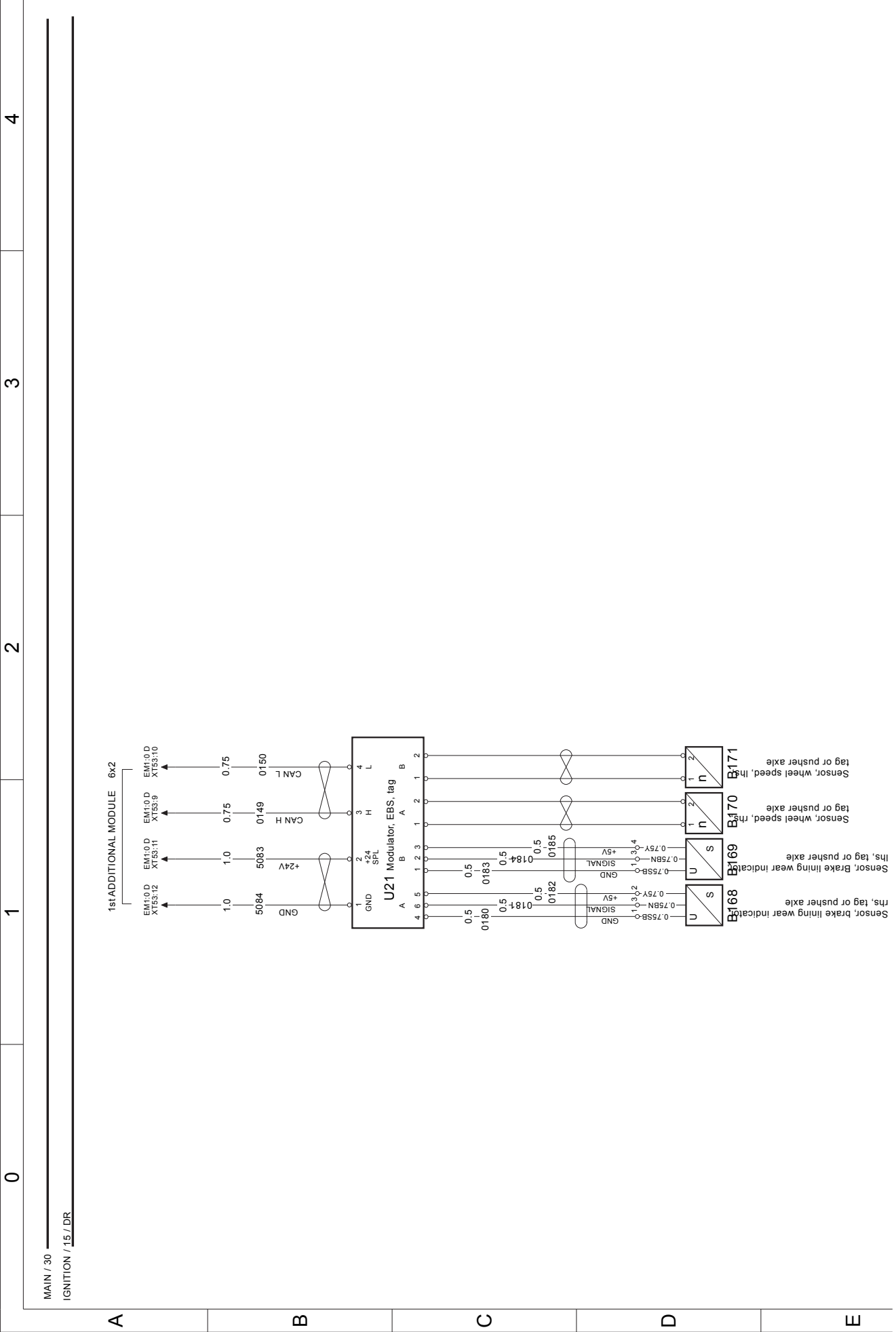

AIR-suspension, TRACTOR 4x2 FSS-LEAF

WIRING DIAGRAM FA

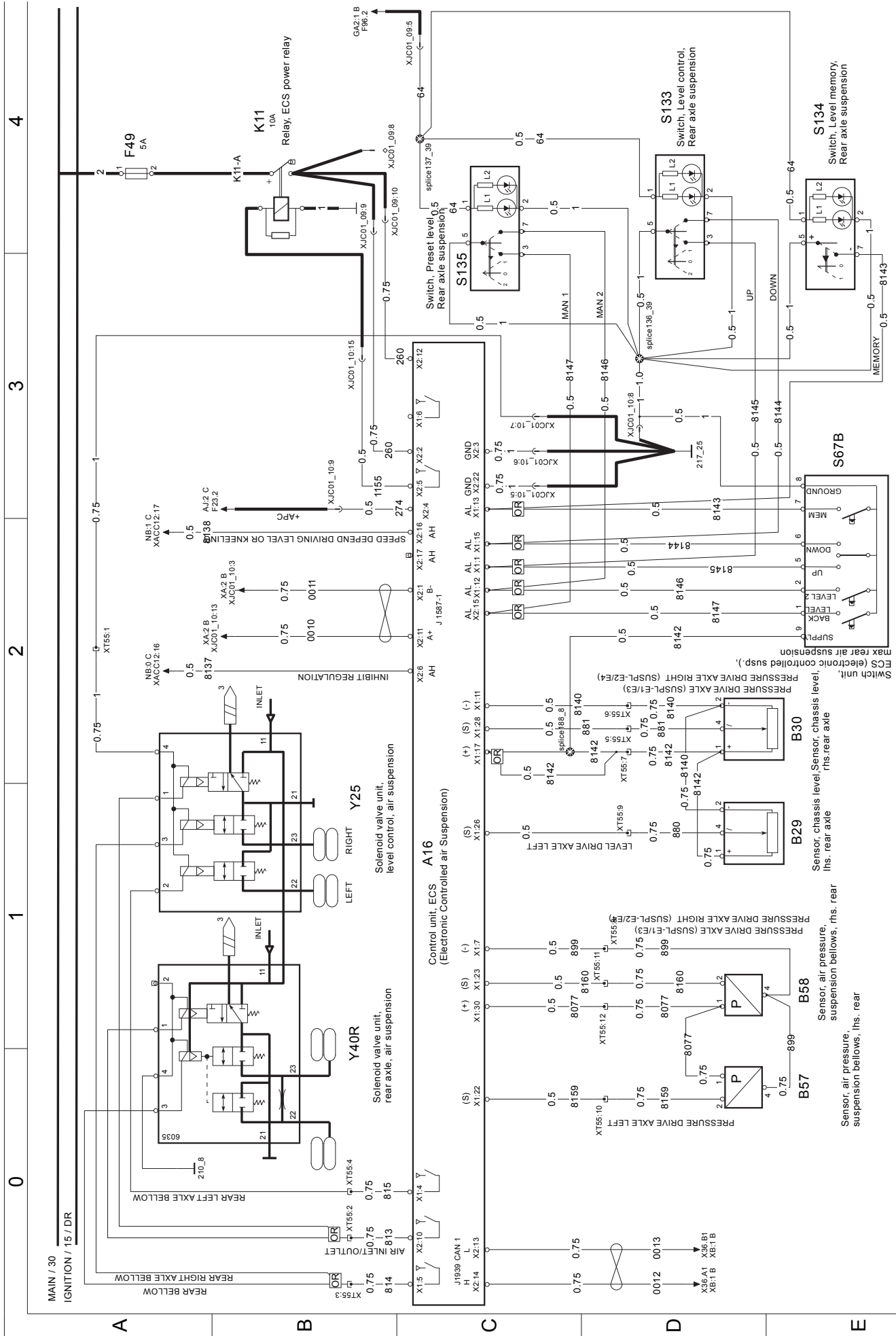

0 1 2 3 4

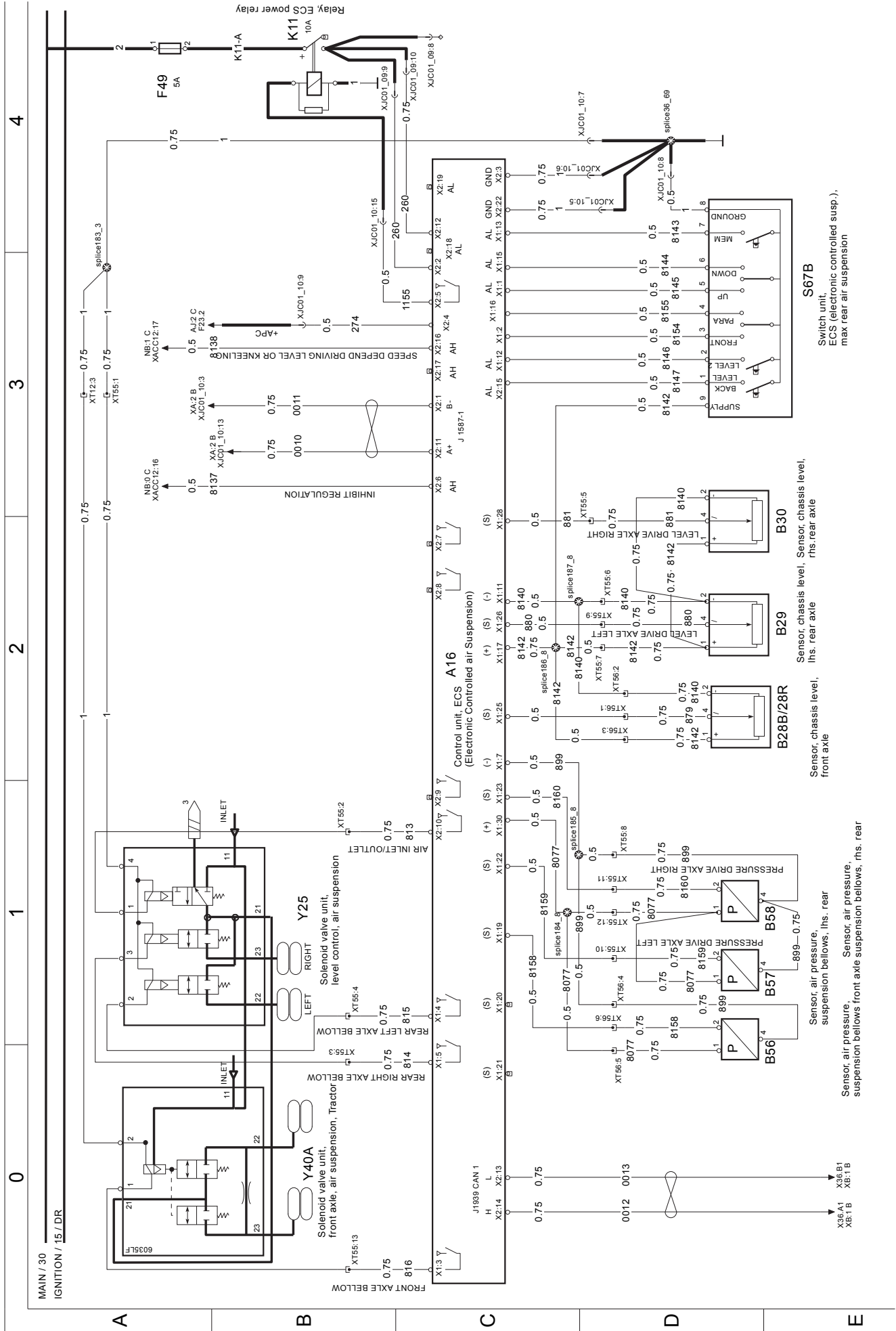

AIR-suspension, 6x2

WIRING DIAGRAM FA2

4

3

2

1

0

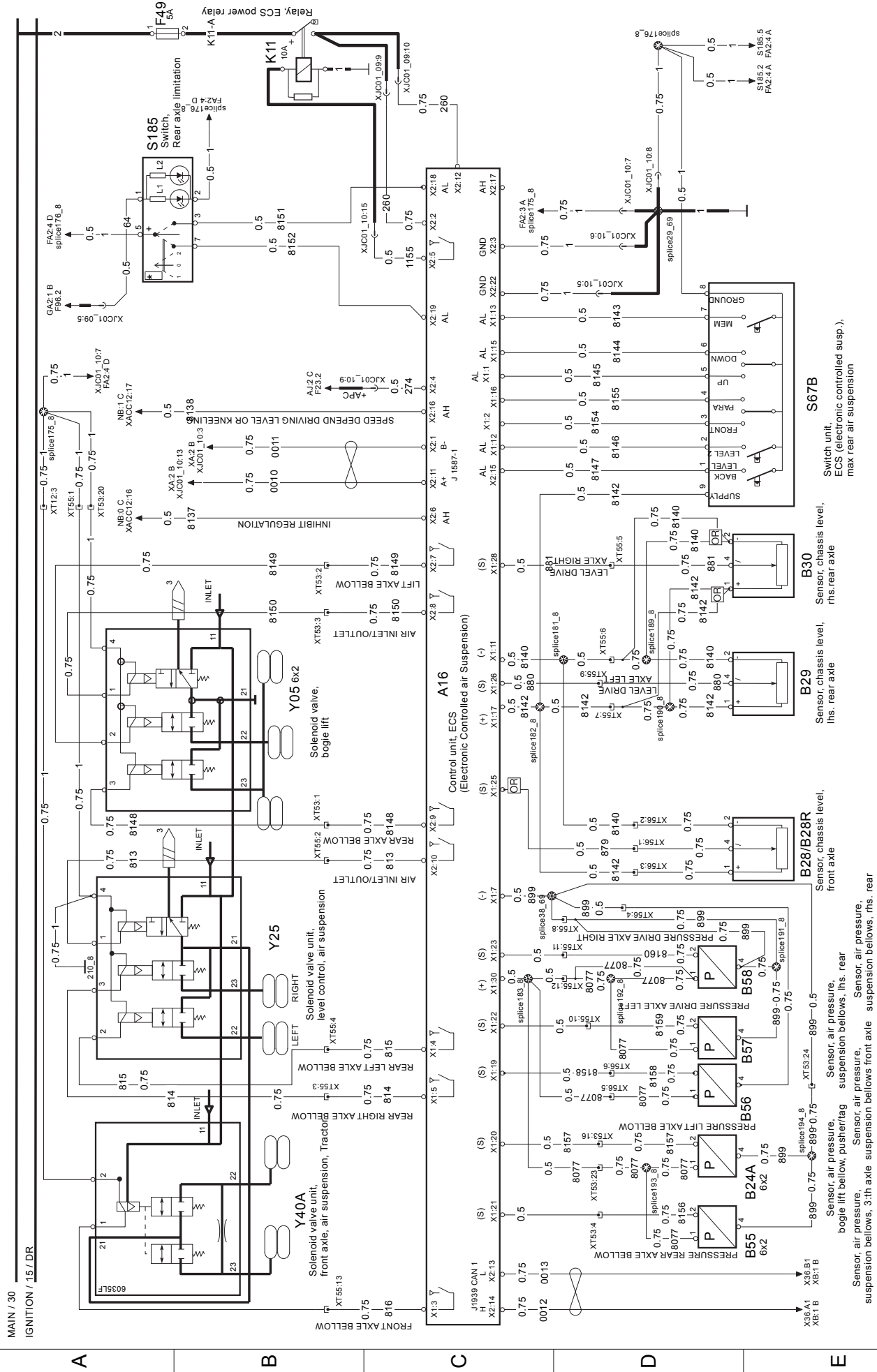

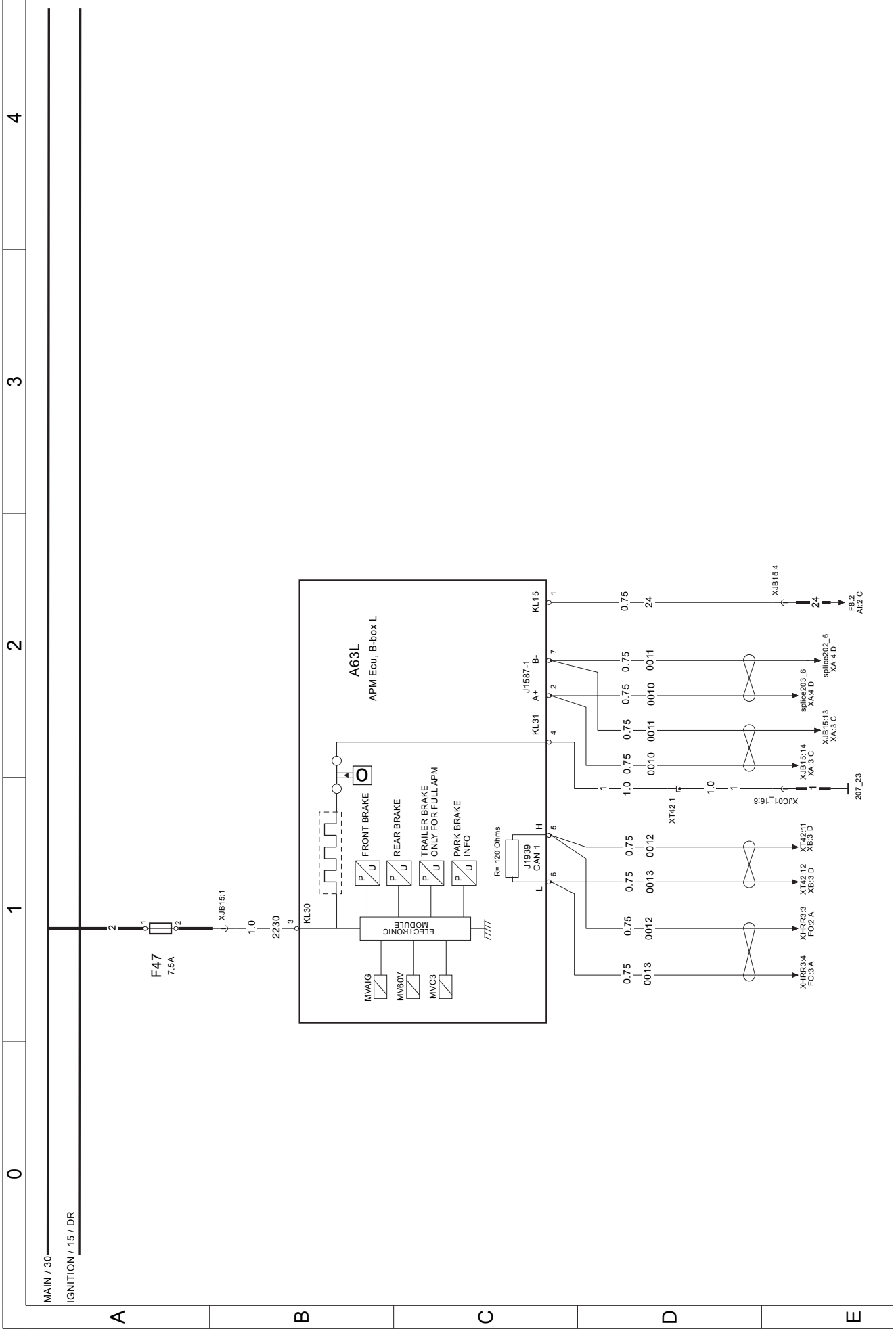

WIRING DIAGRAM FC1

AIR power management (battery box right)

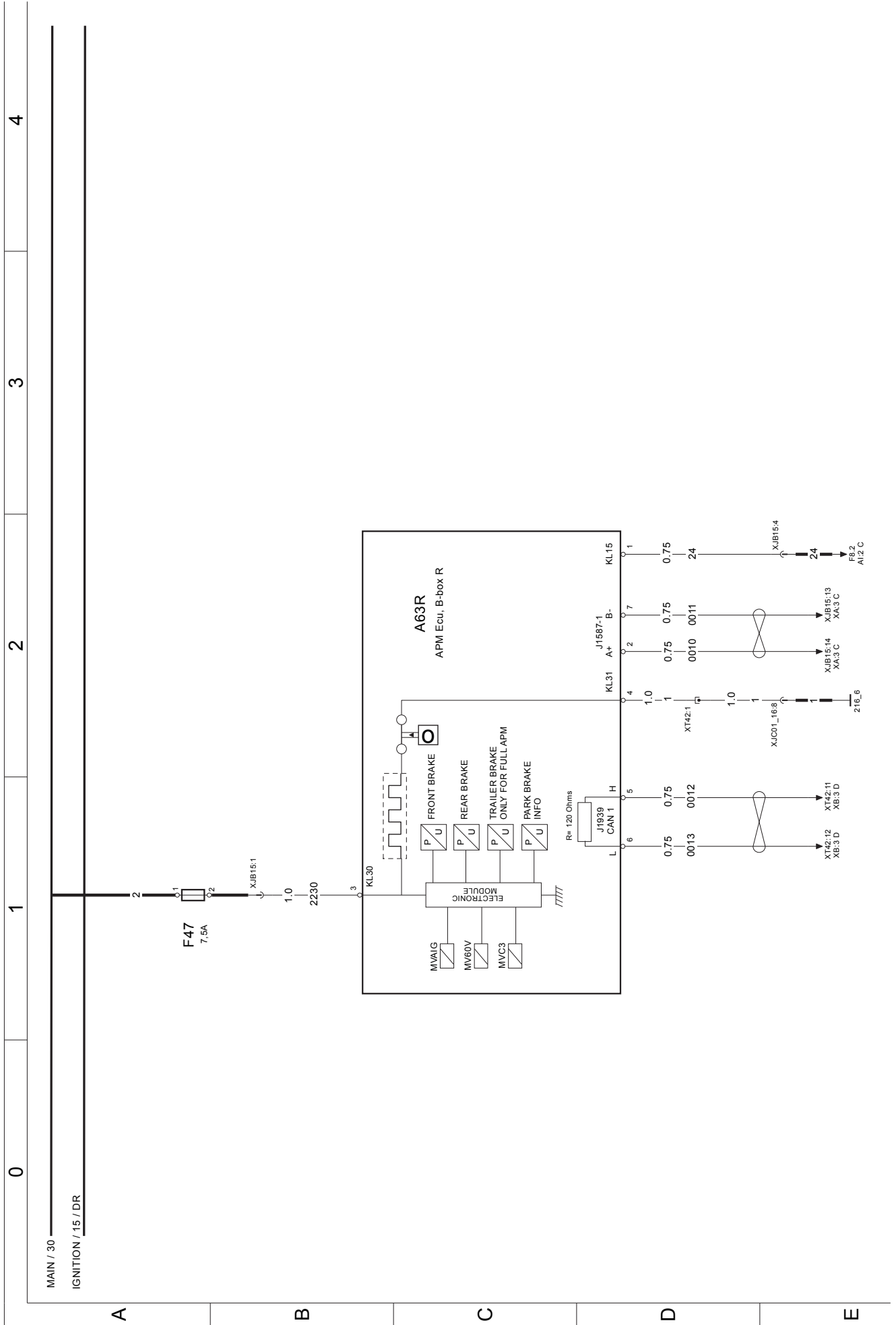

0 1 2 3 4

MAIN / 30
IGNITION / 15 / DR

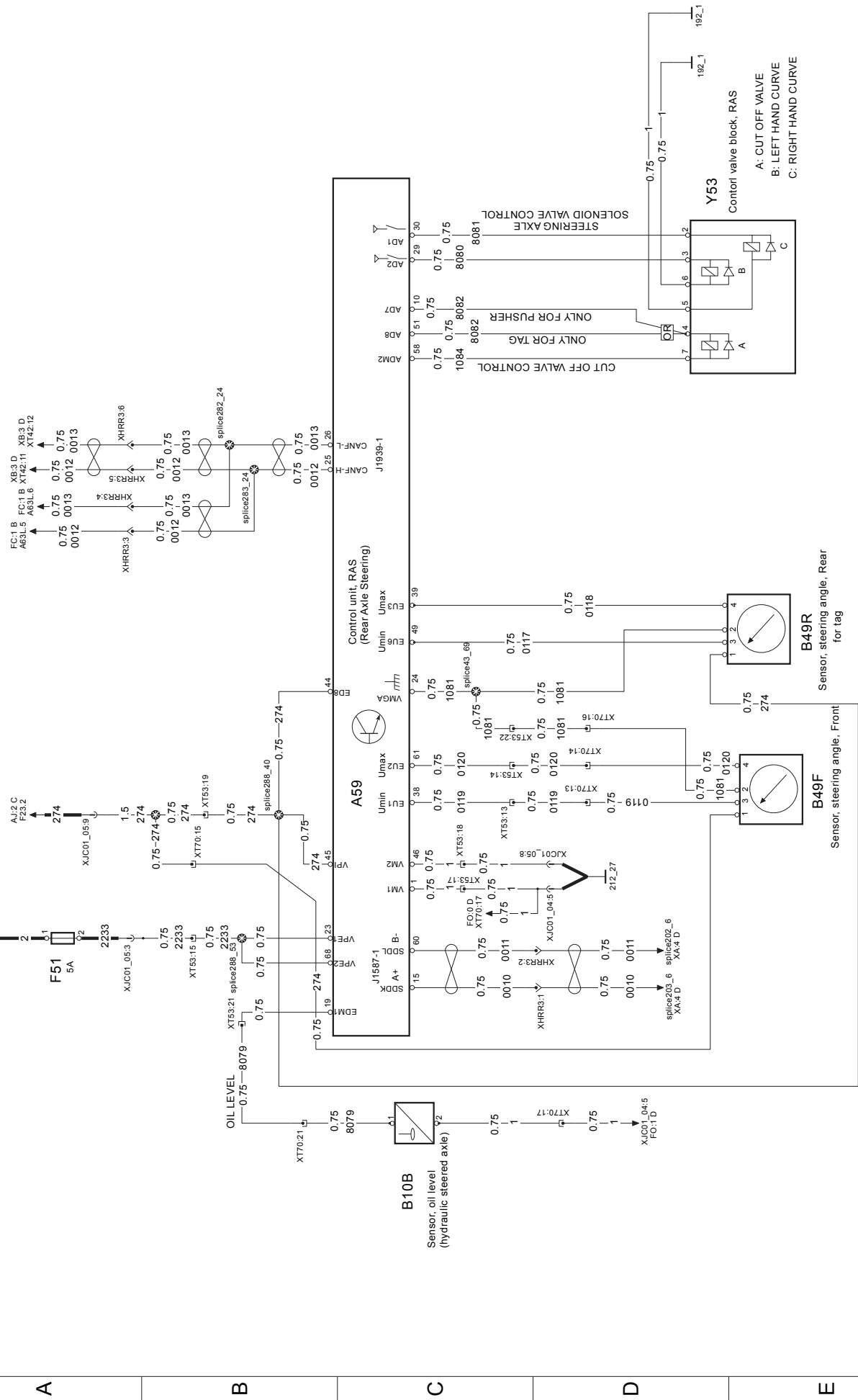

Parking lights, Relay K31/K37

WIRING DIAGRAM GA1

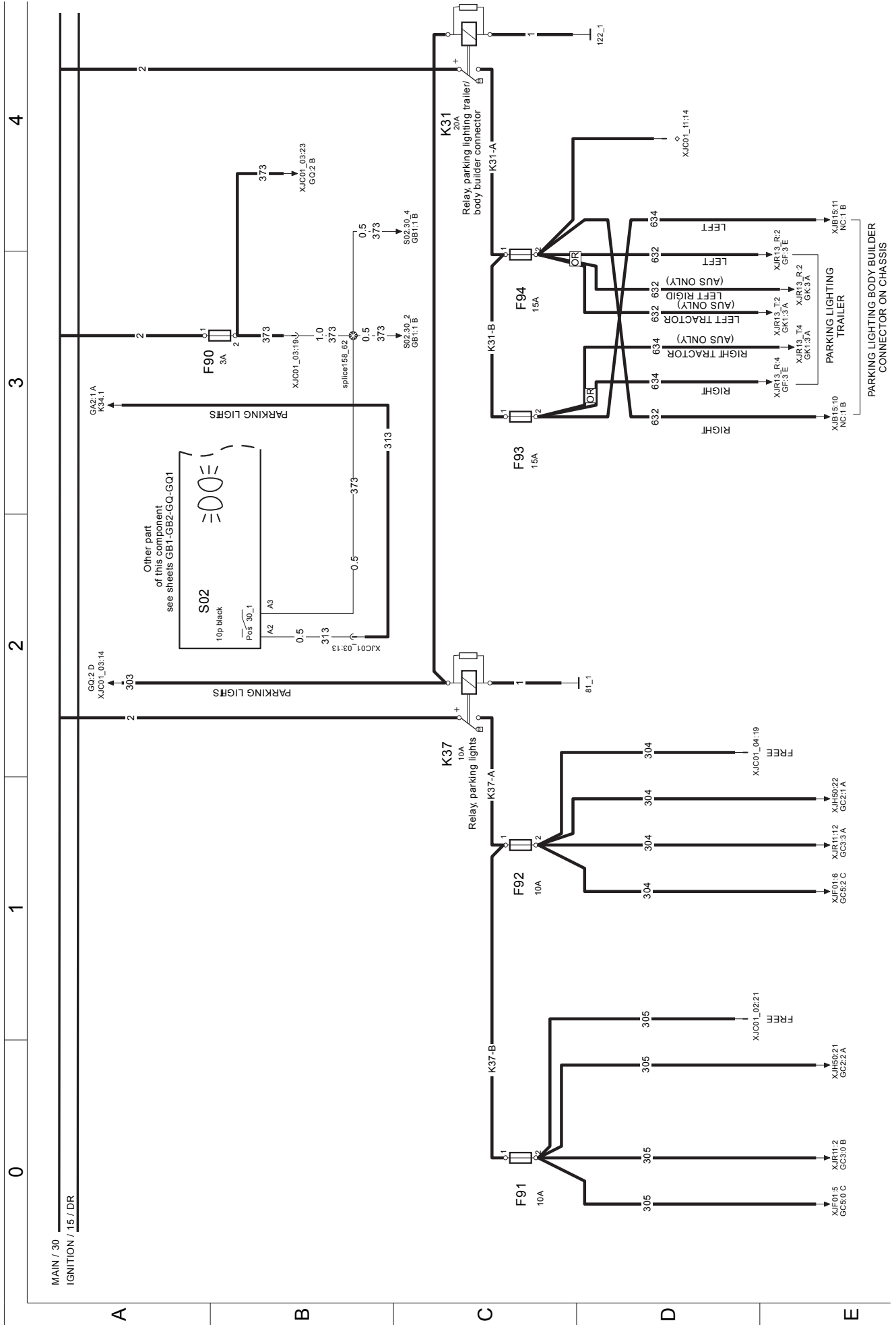

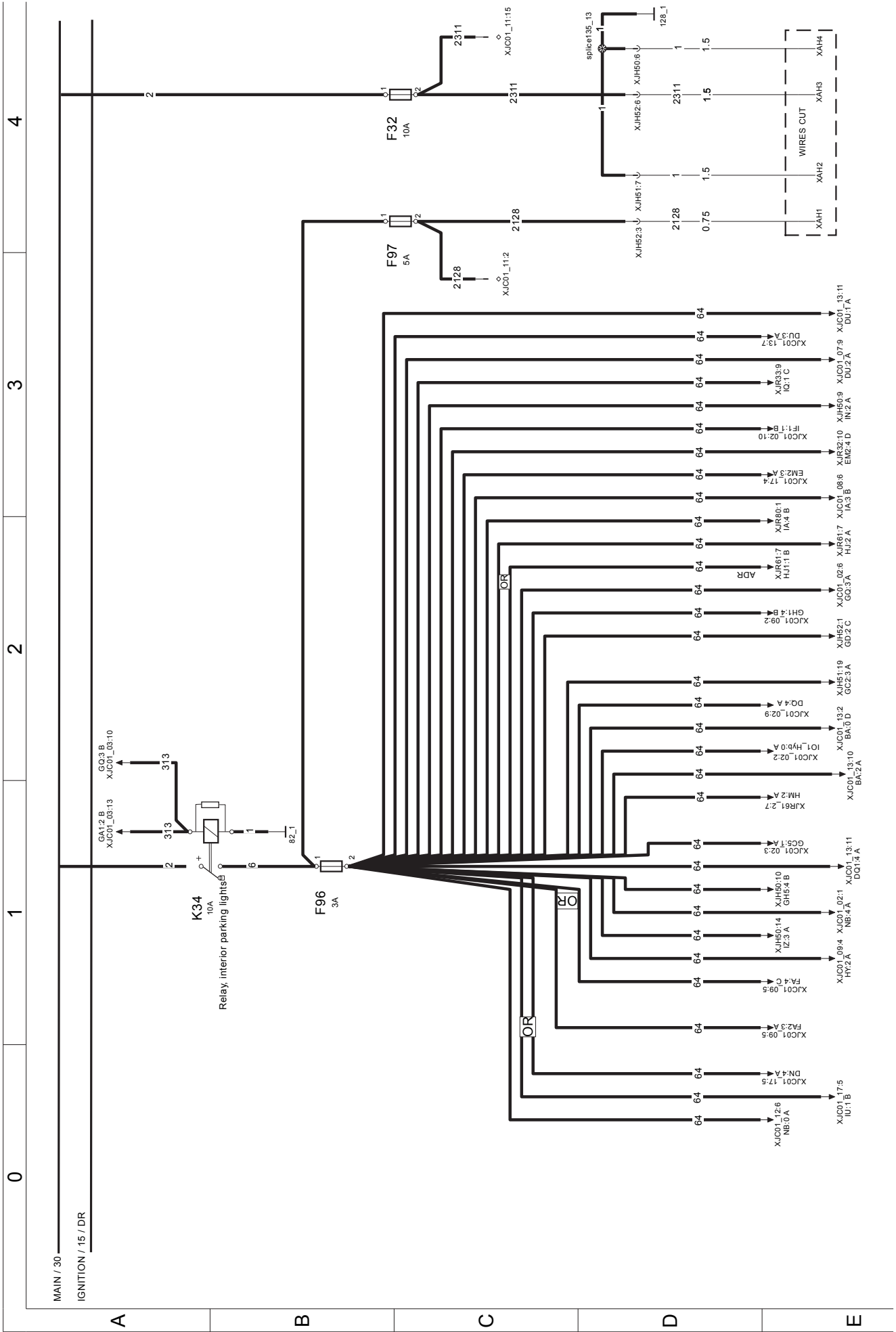

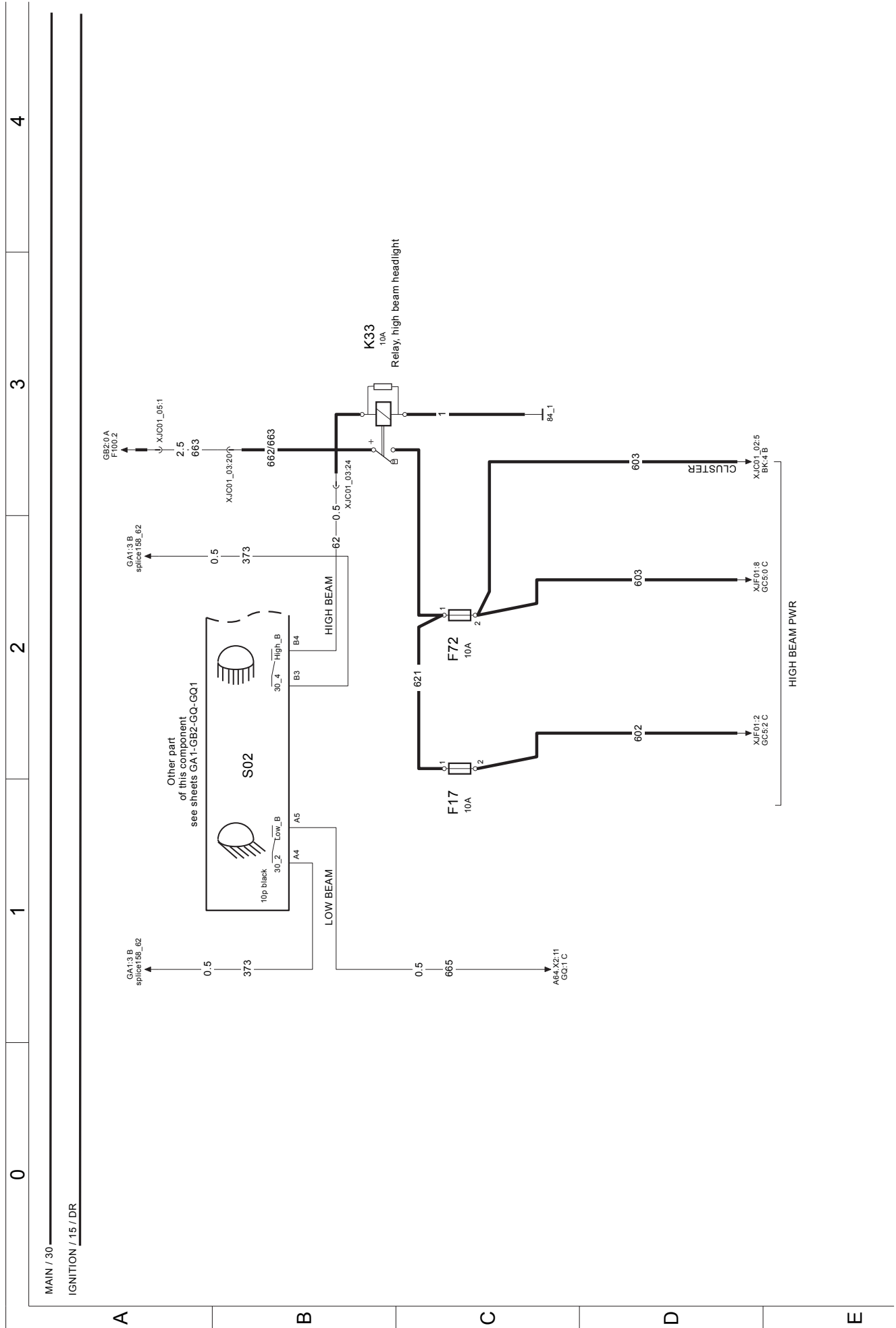

0

1

2

3

4

MAIN / 30

IGNITION / 15 / DR

A

B

C

D

E

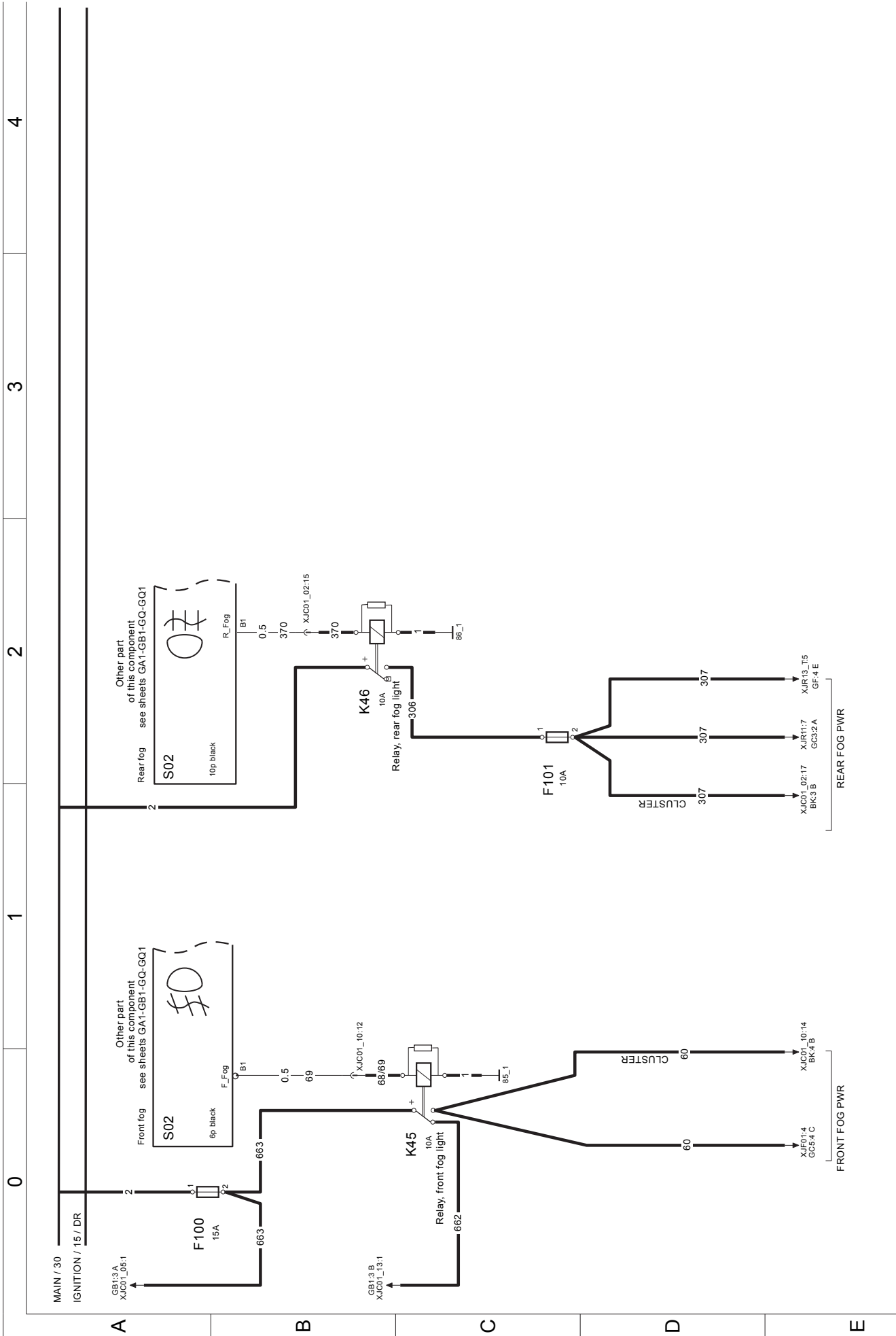

WIRING DIAGRAM GC2

Side lights and beacon warning lights

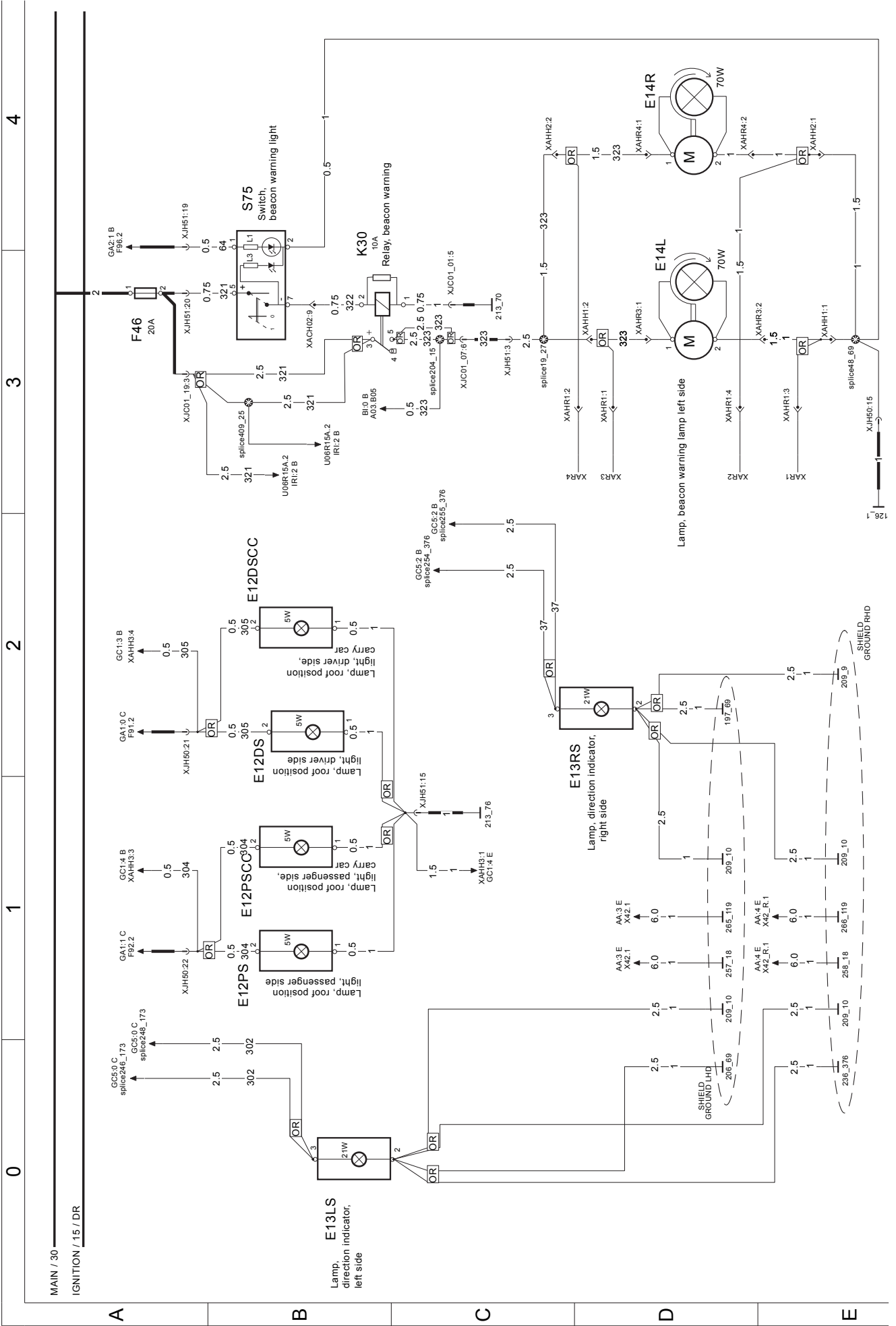

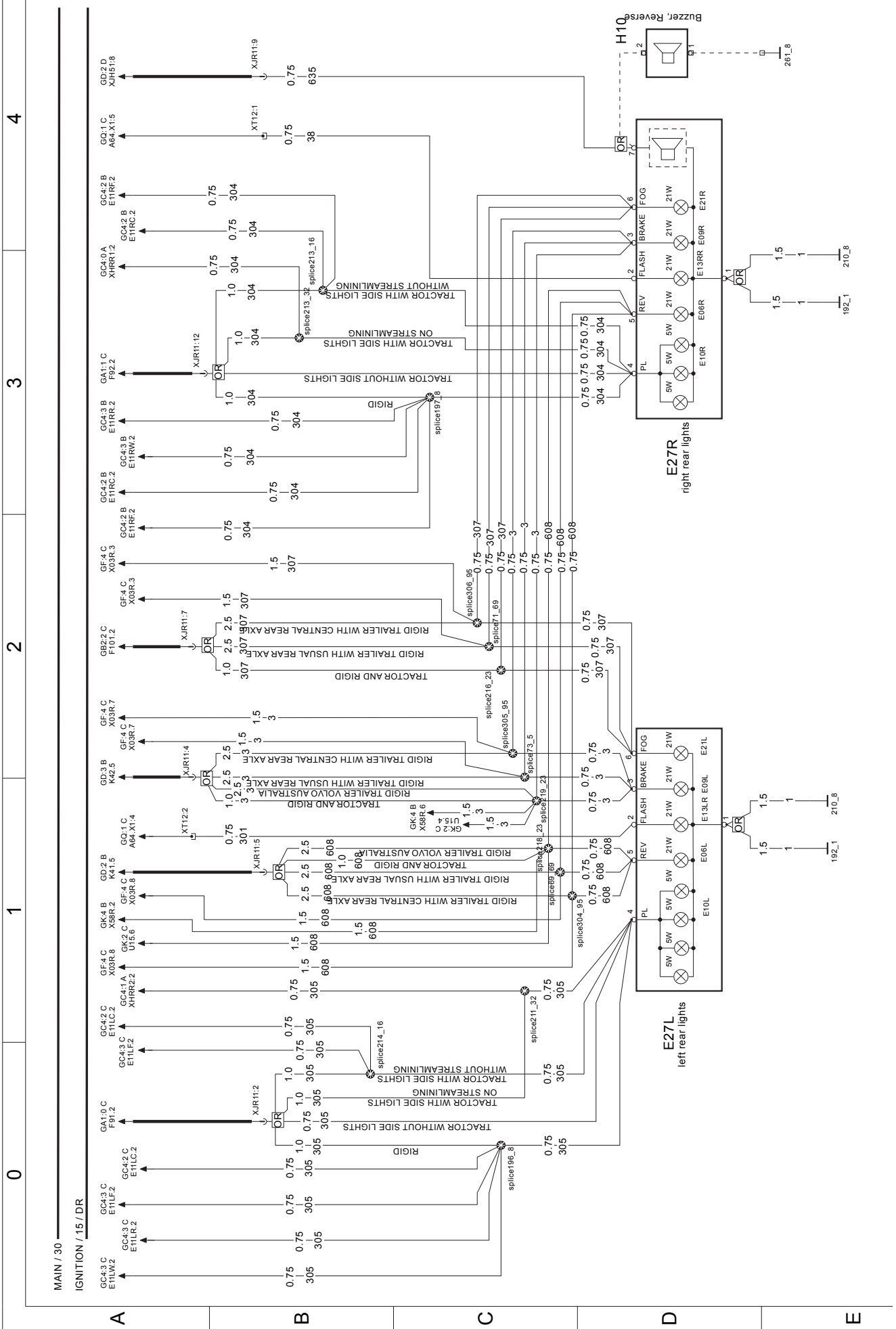

MAIN/ 30

IGNITION / 15 / DR

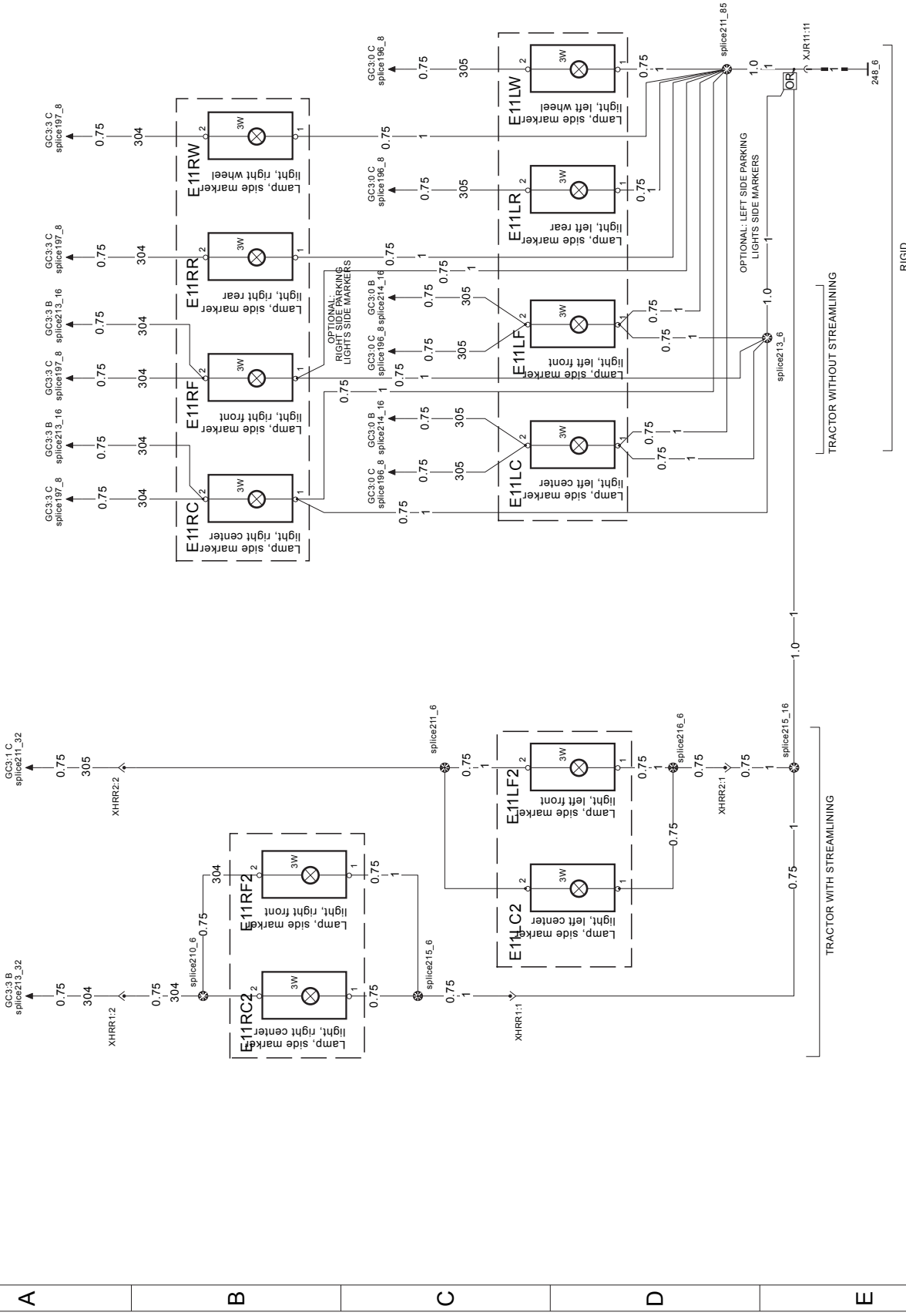

TRACTOR WITHOUT STREAMLINING

TRACTOR WITH STREAMLINING

RIGID

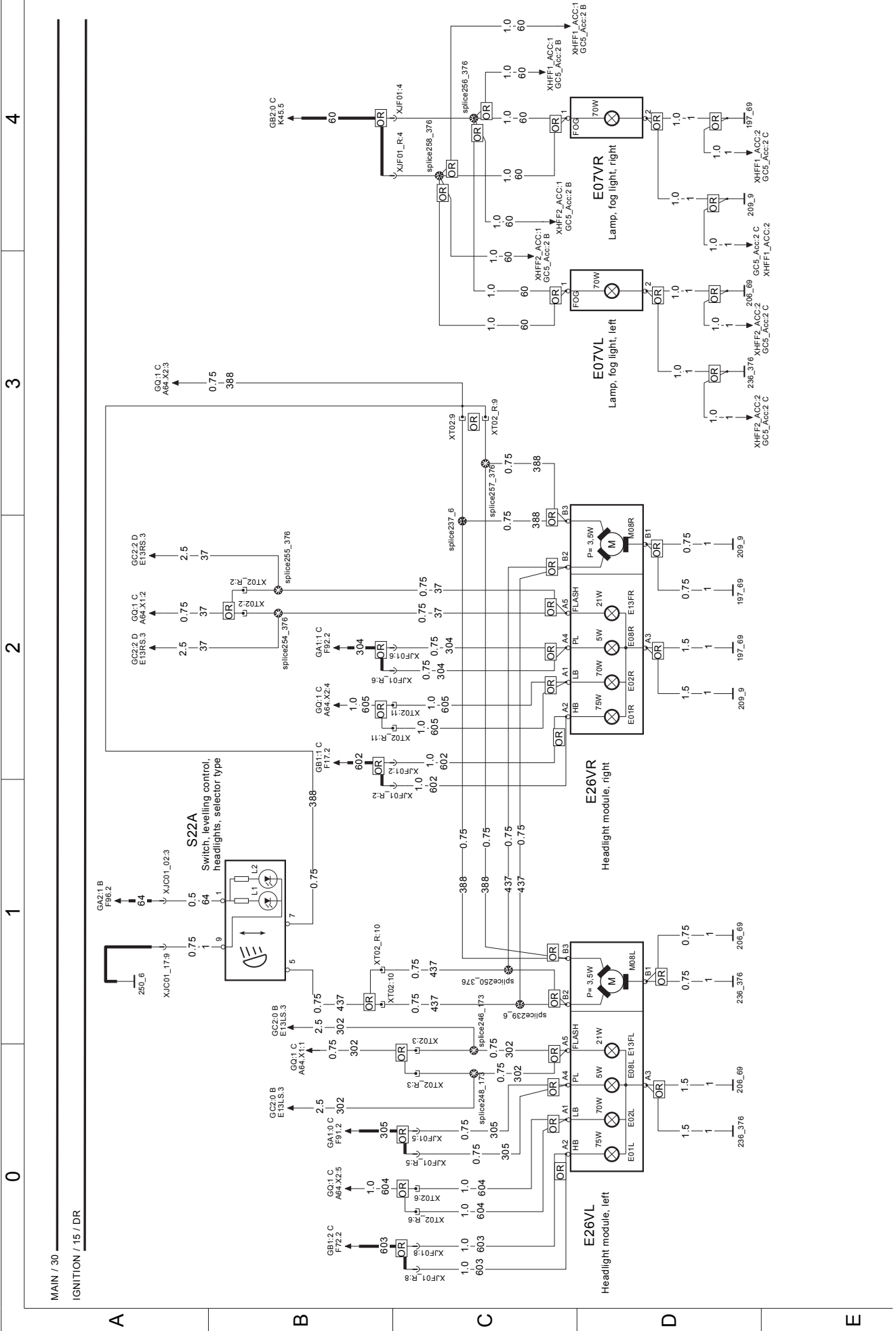

Reverse lights/brake lights

WIRING DIAGRAM GD

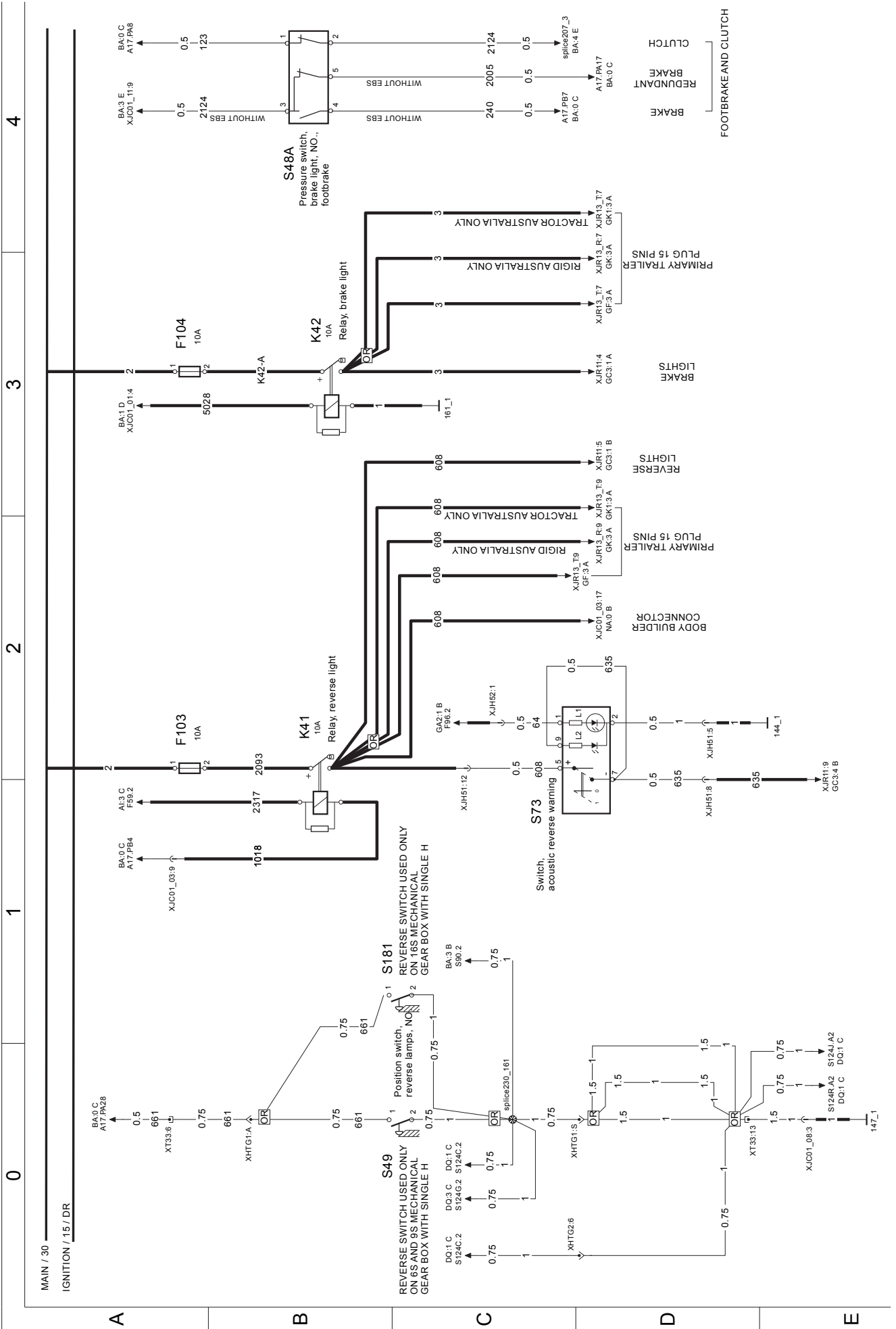

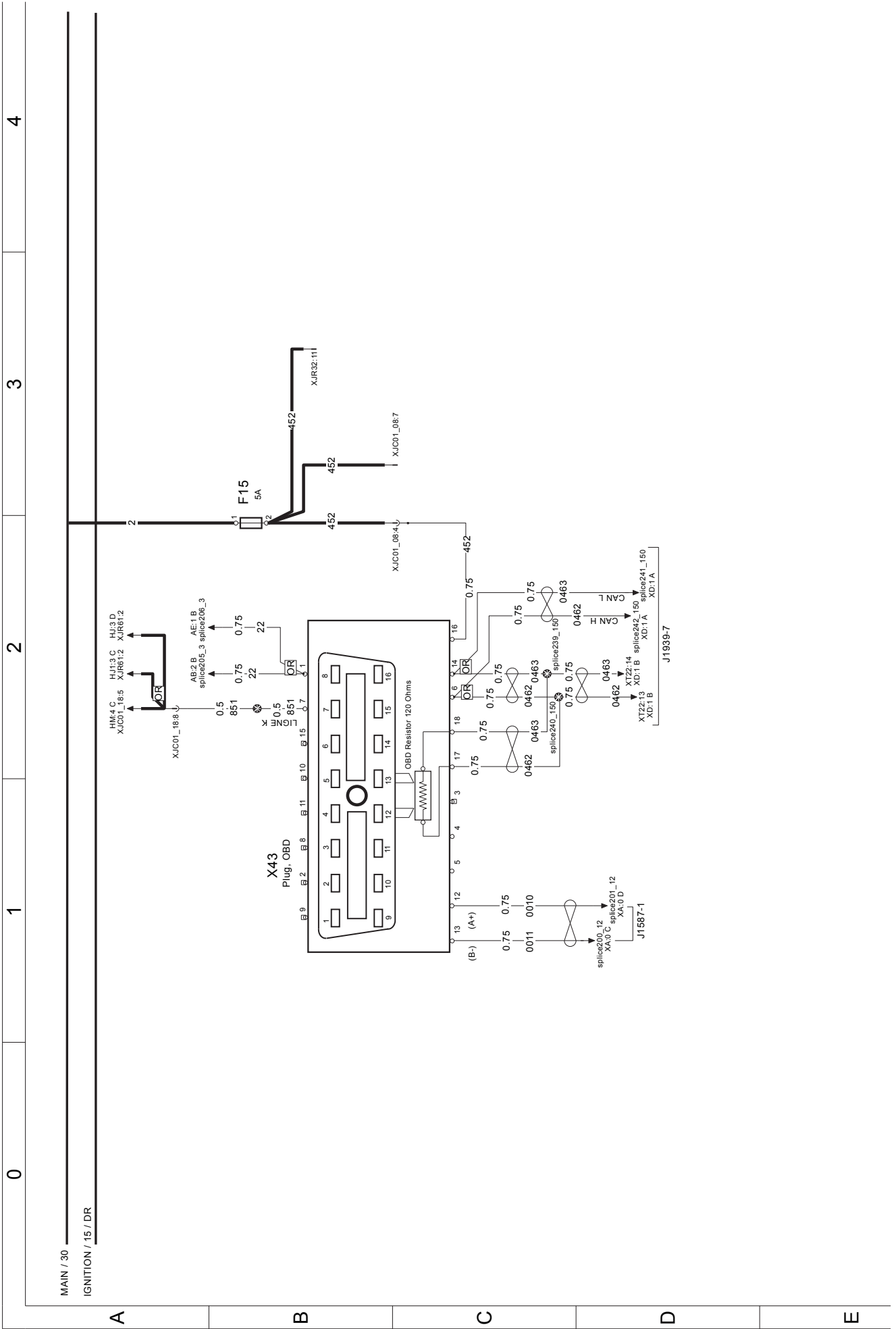

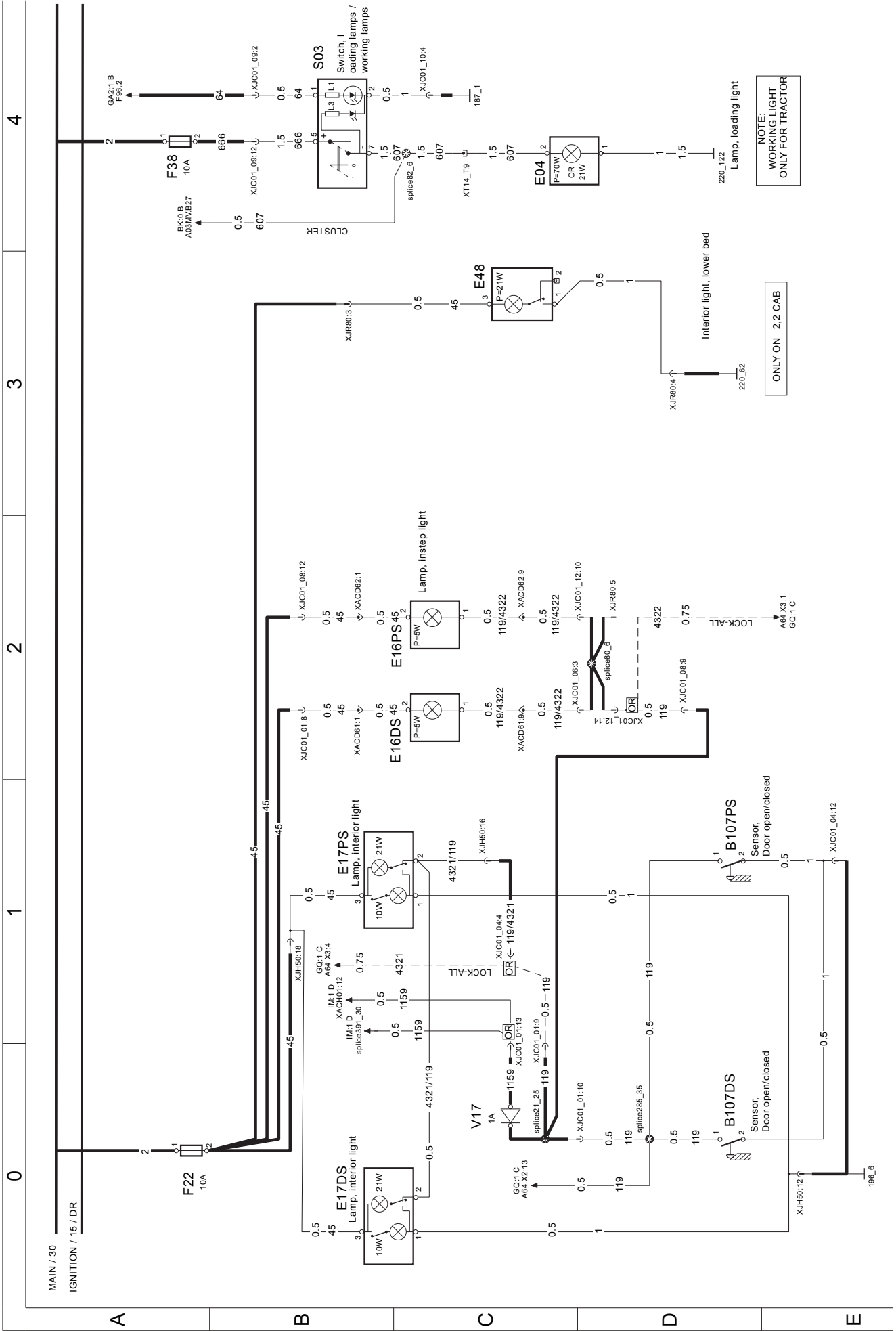

WIRING DIAGRAM GH3

Interior lighting L2H1 back area cab

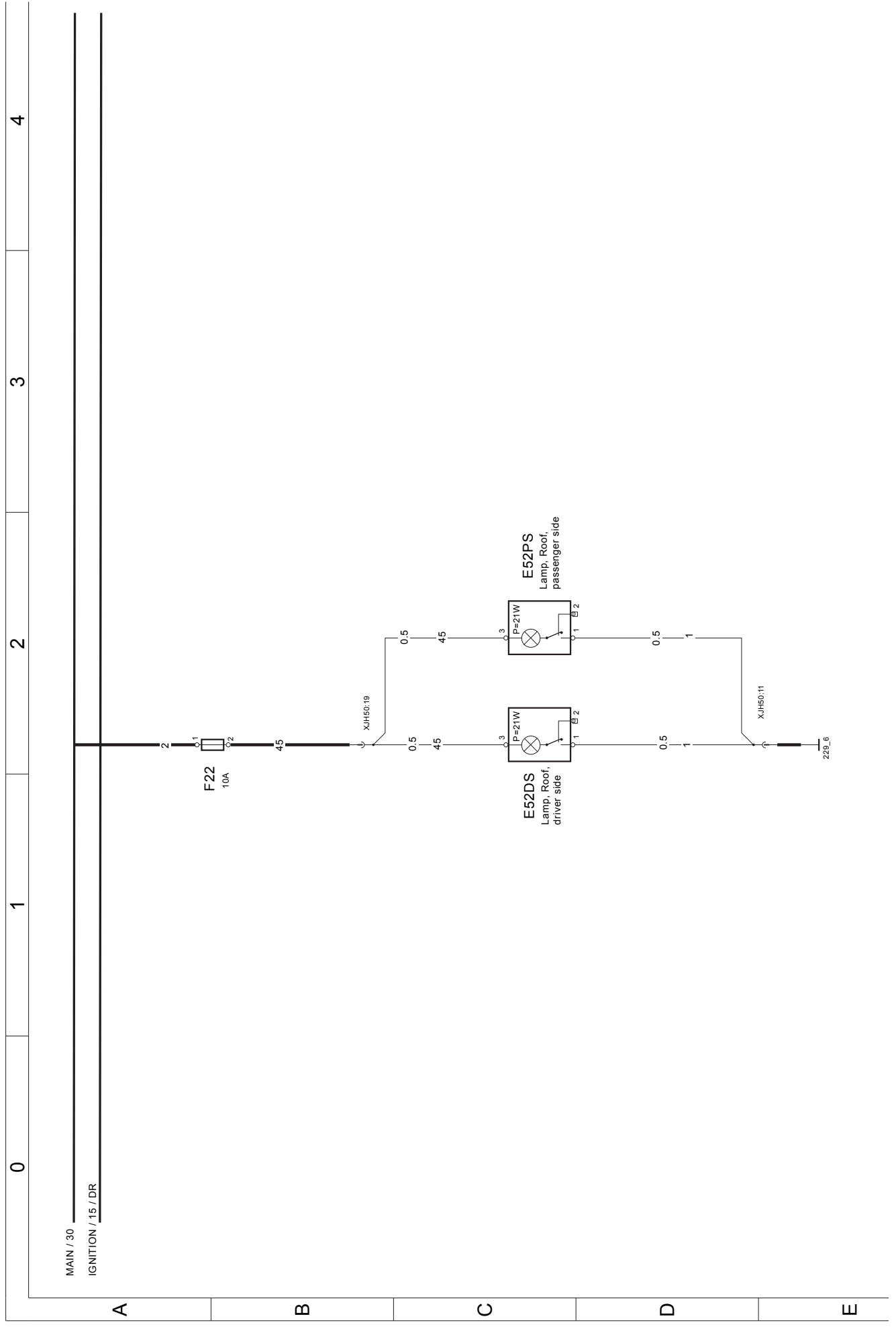

MAIN / 30
IGNITION / 15 / DR

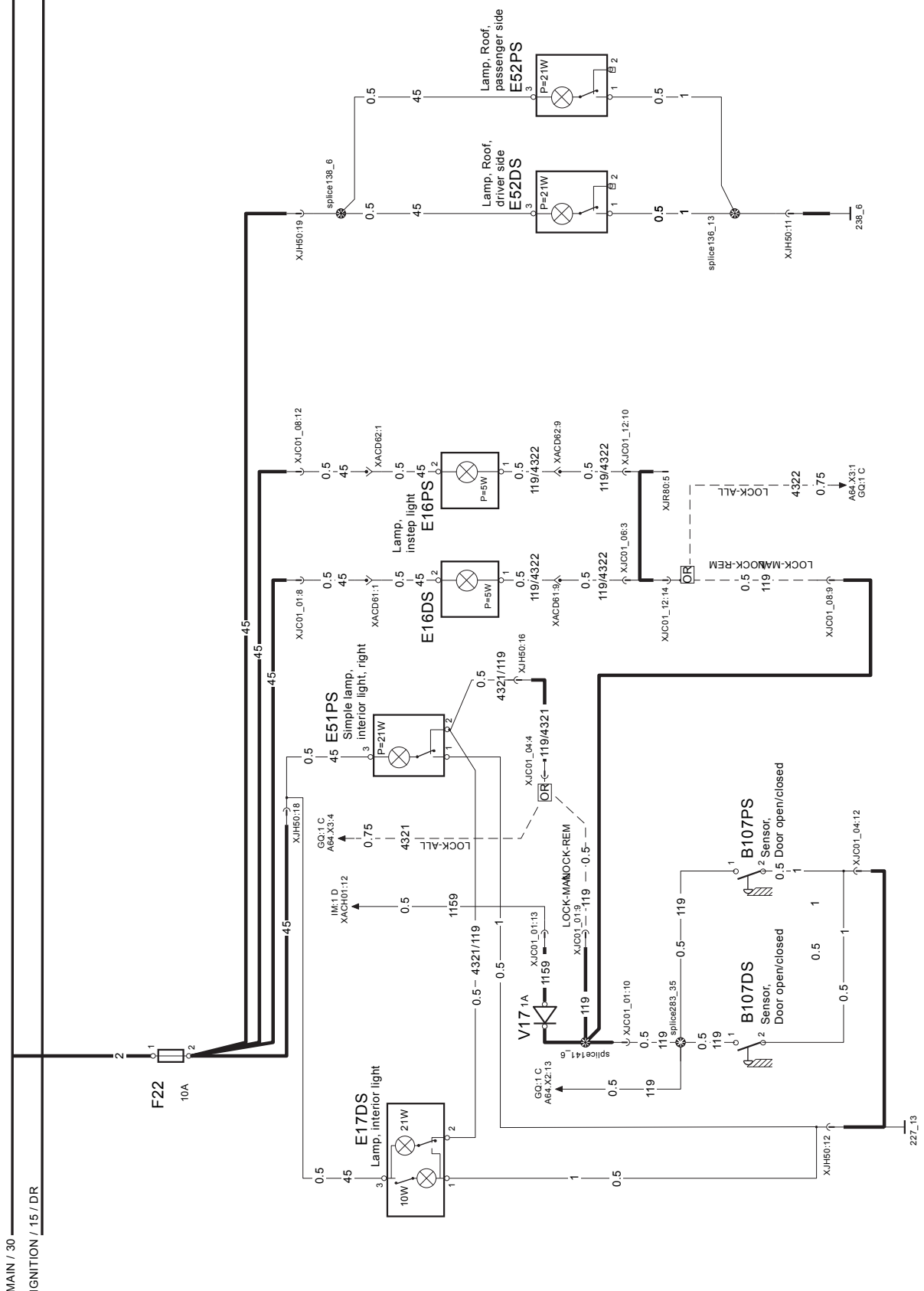

Trailer connections RIGID (Australia)

WIRING DIAGRAM GK

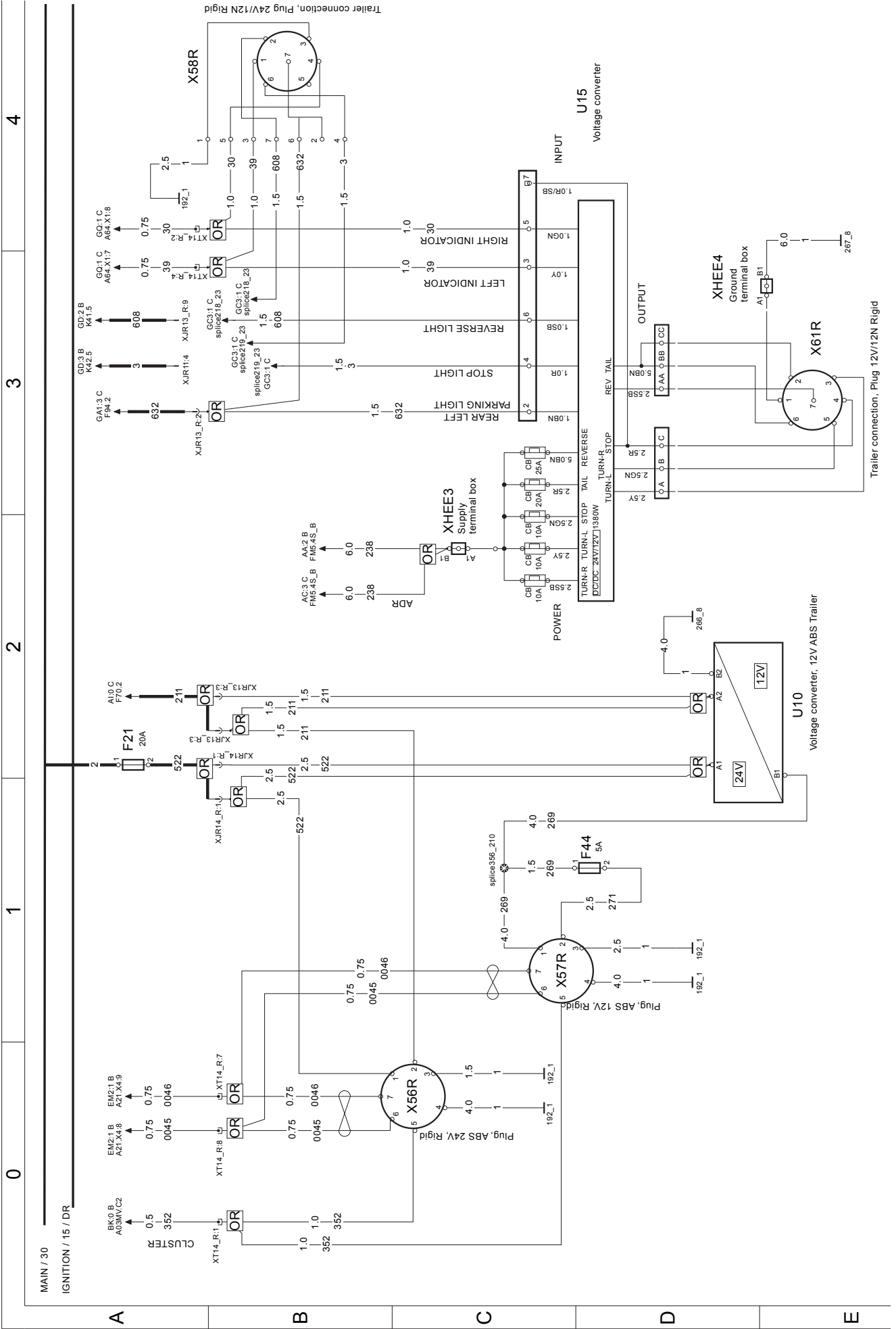

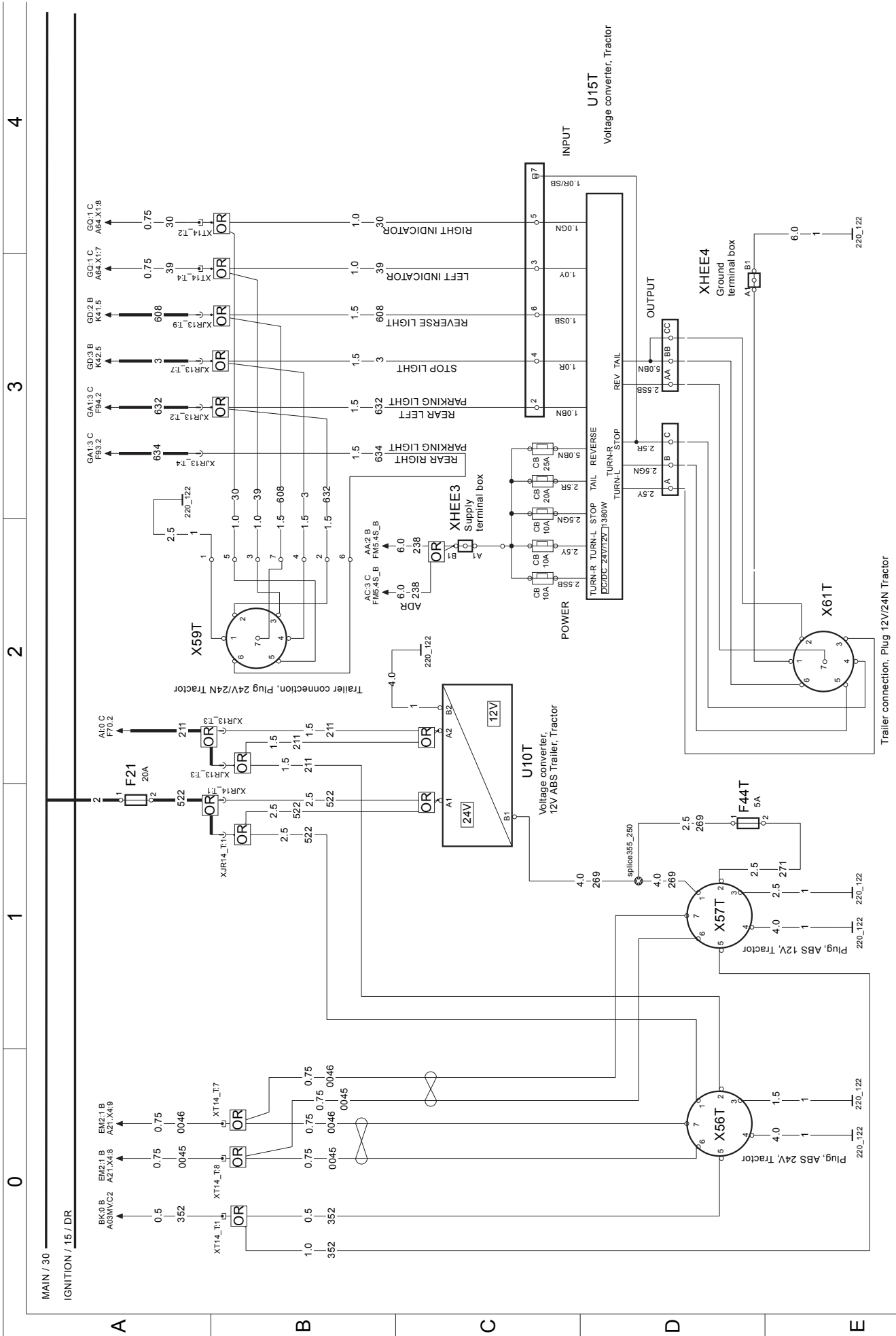

Windscreen wiper washer

WIRING DIAGRAM GM

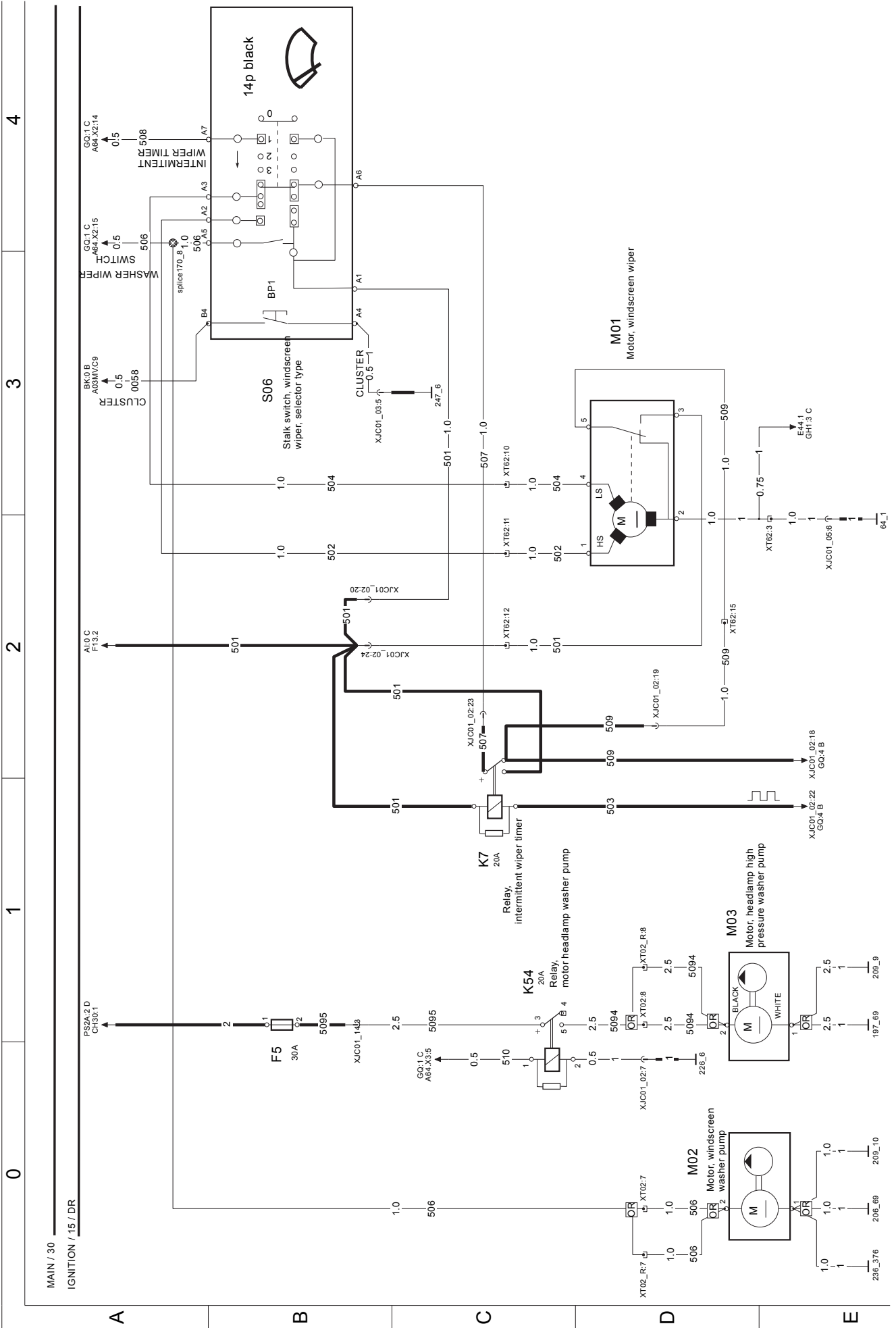

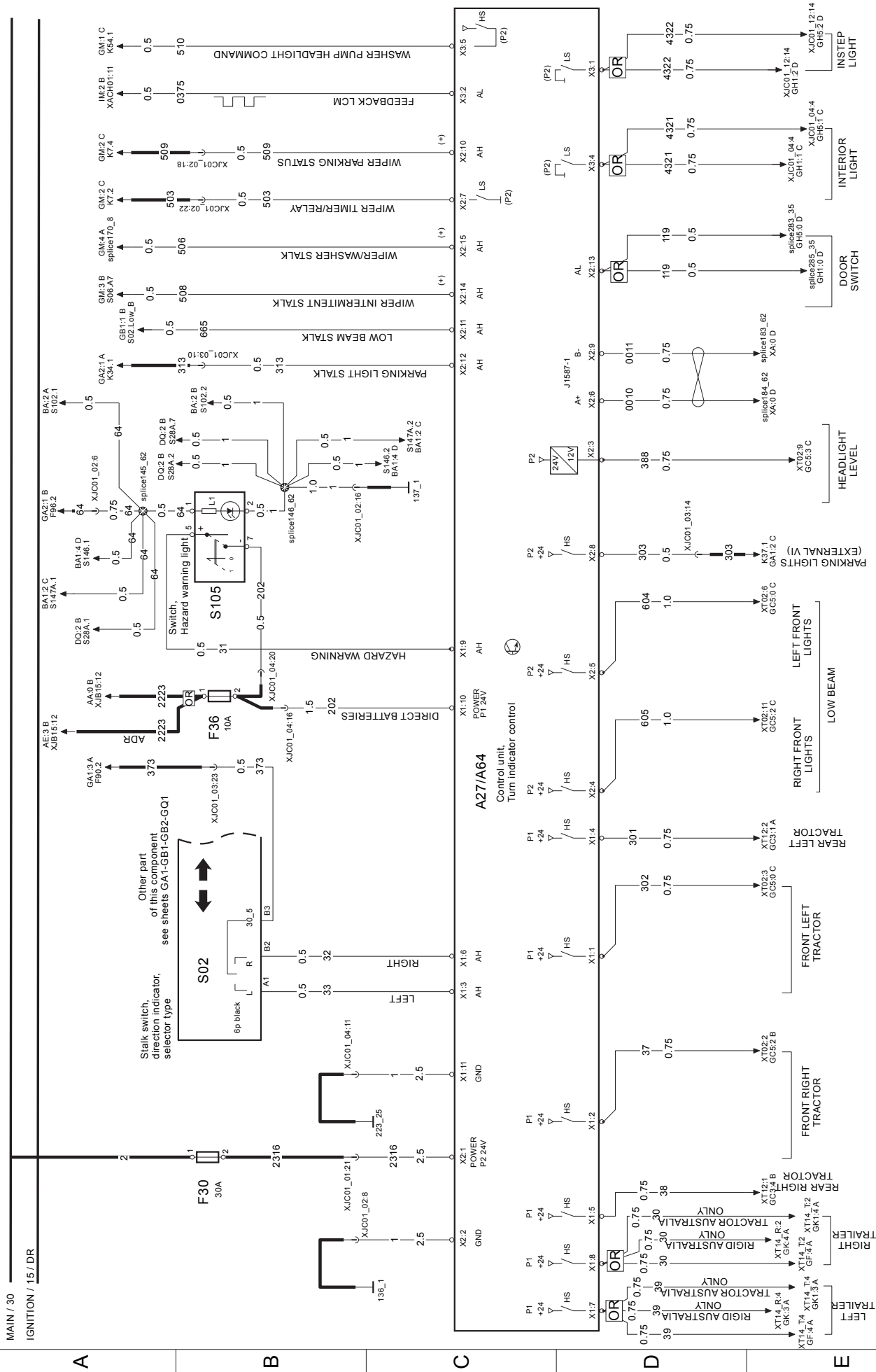

WIRING DIAGRAM GQ1

Horn

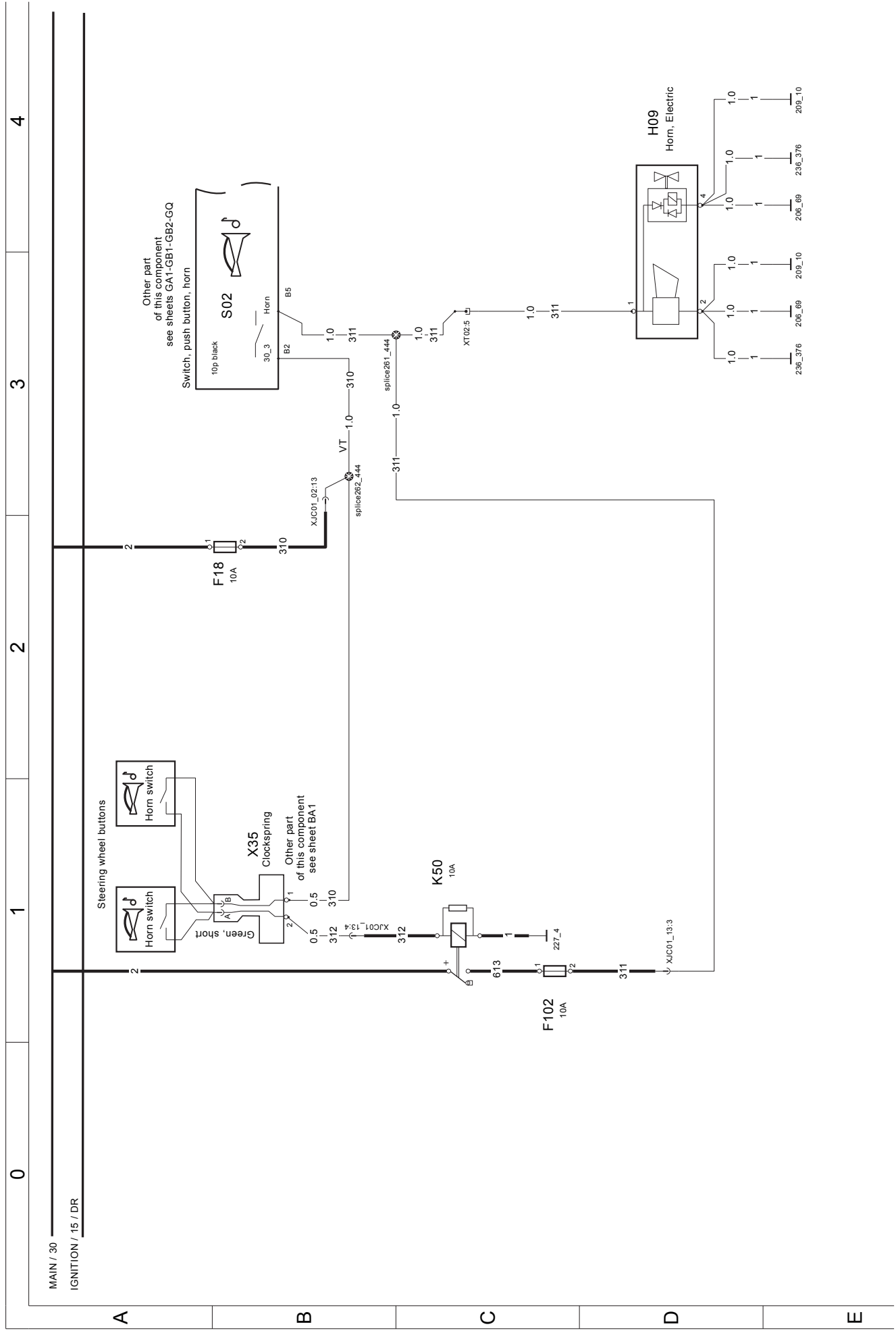

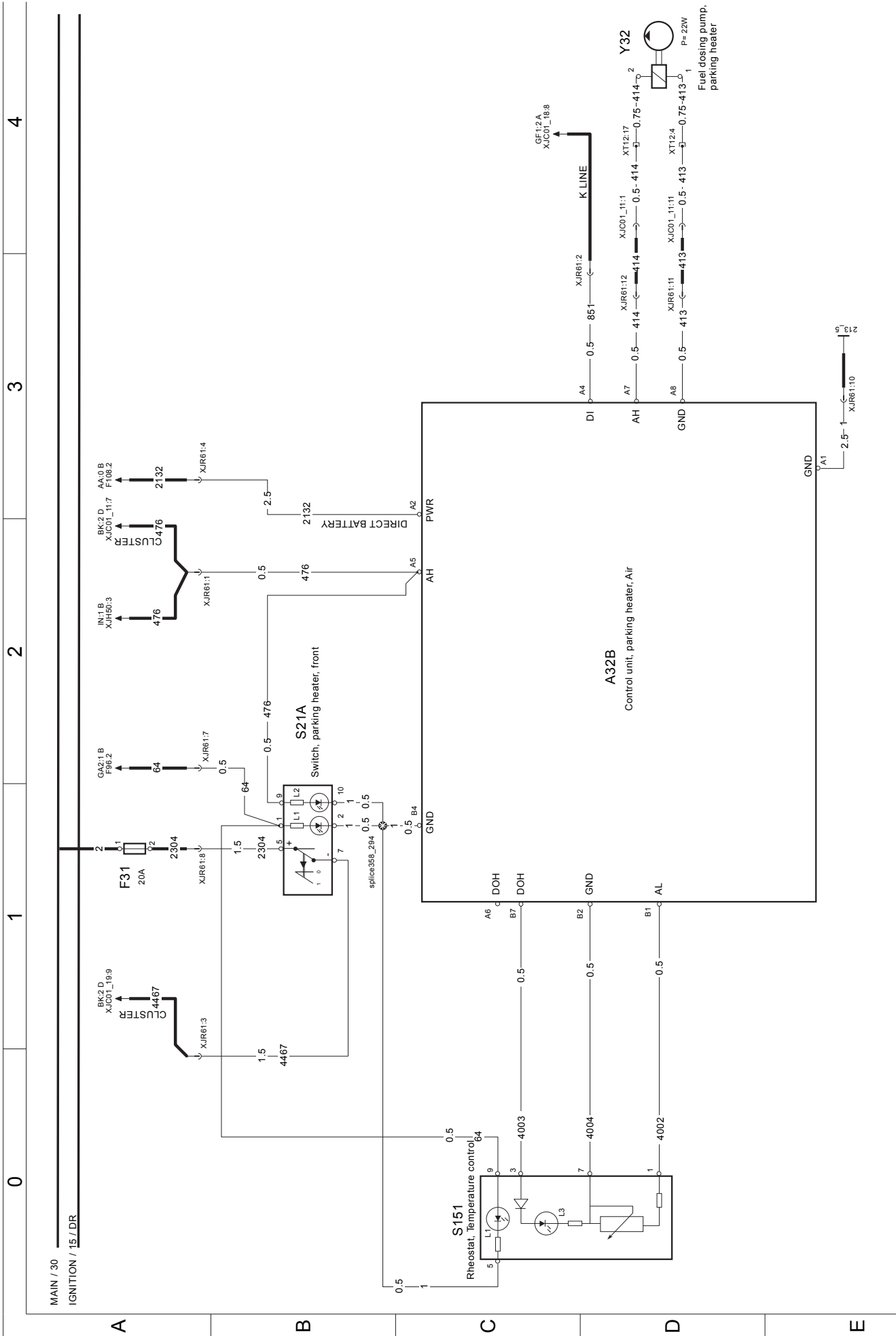

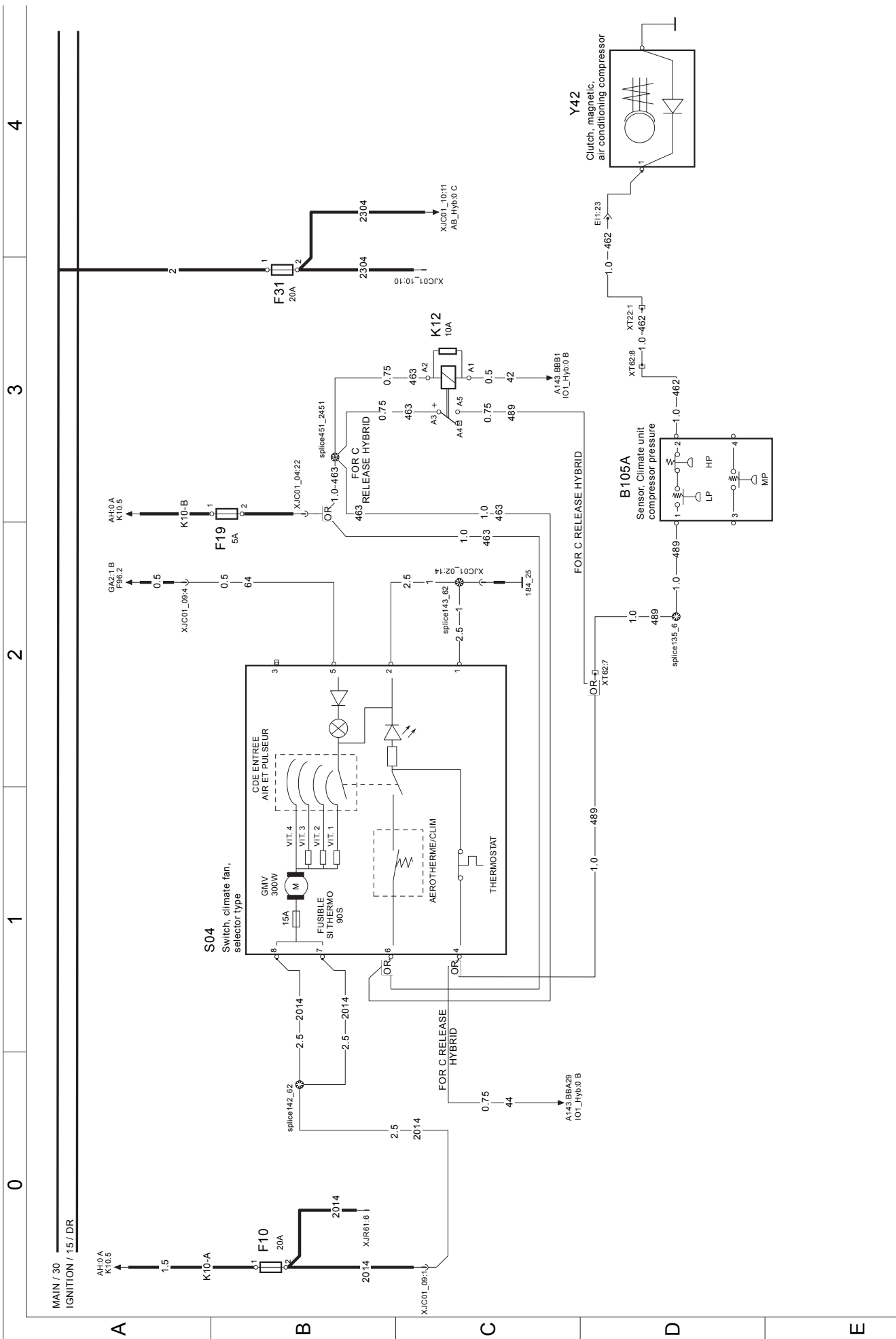

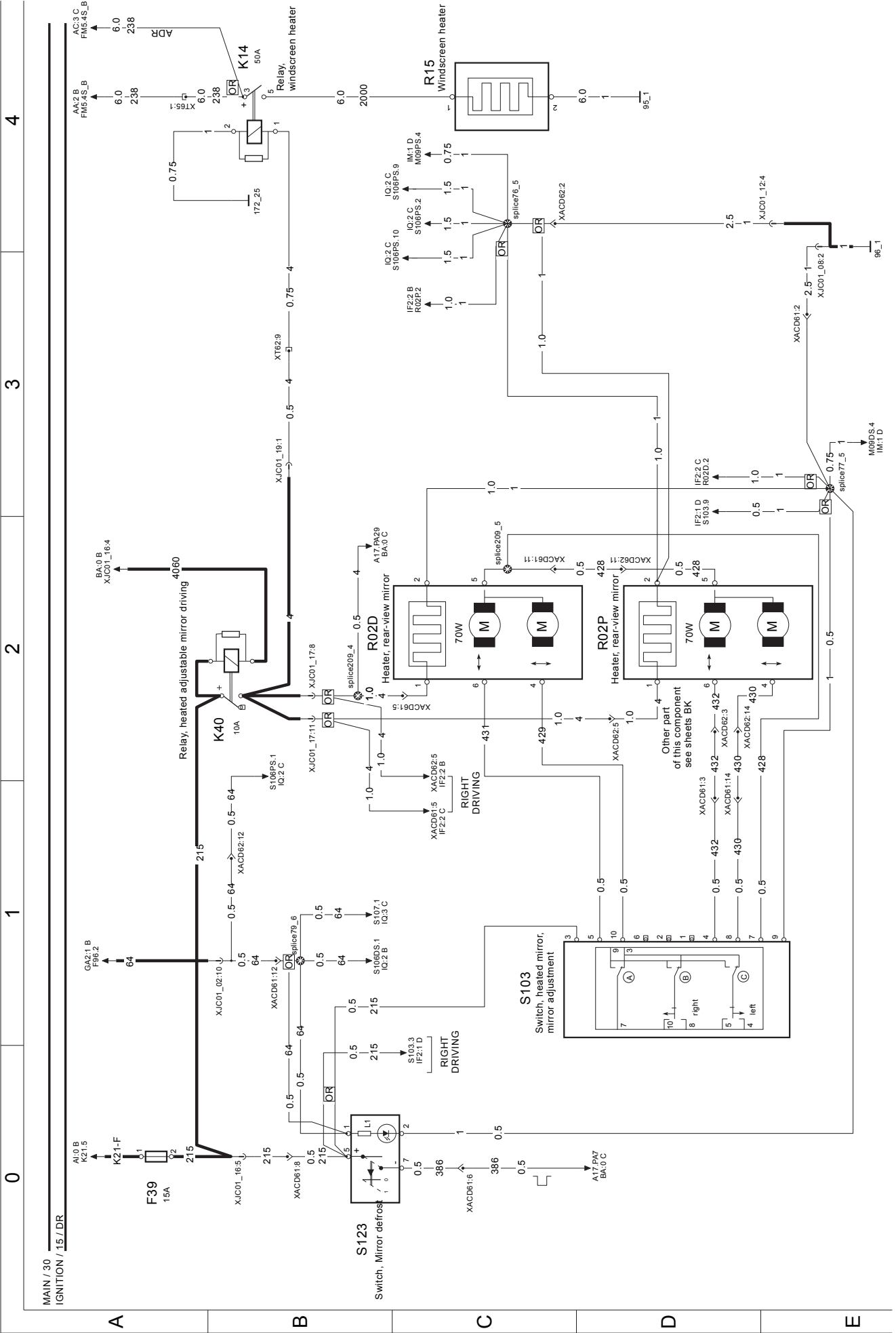

Theft alarm

WIRING DIAGRAM IN

4

3

2

1

0

MAIN / 30

IGNITION / 15 / DR

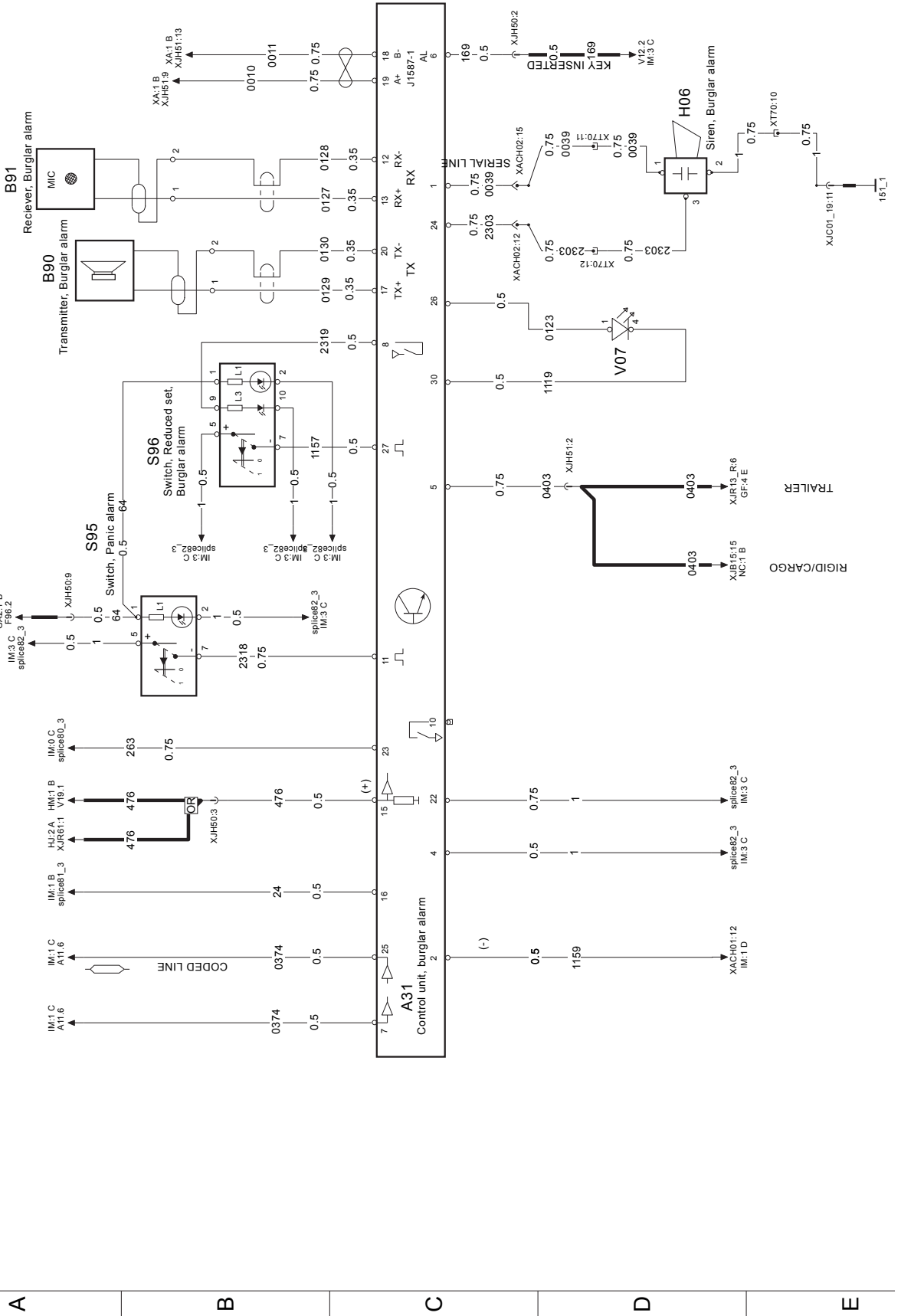

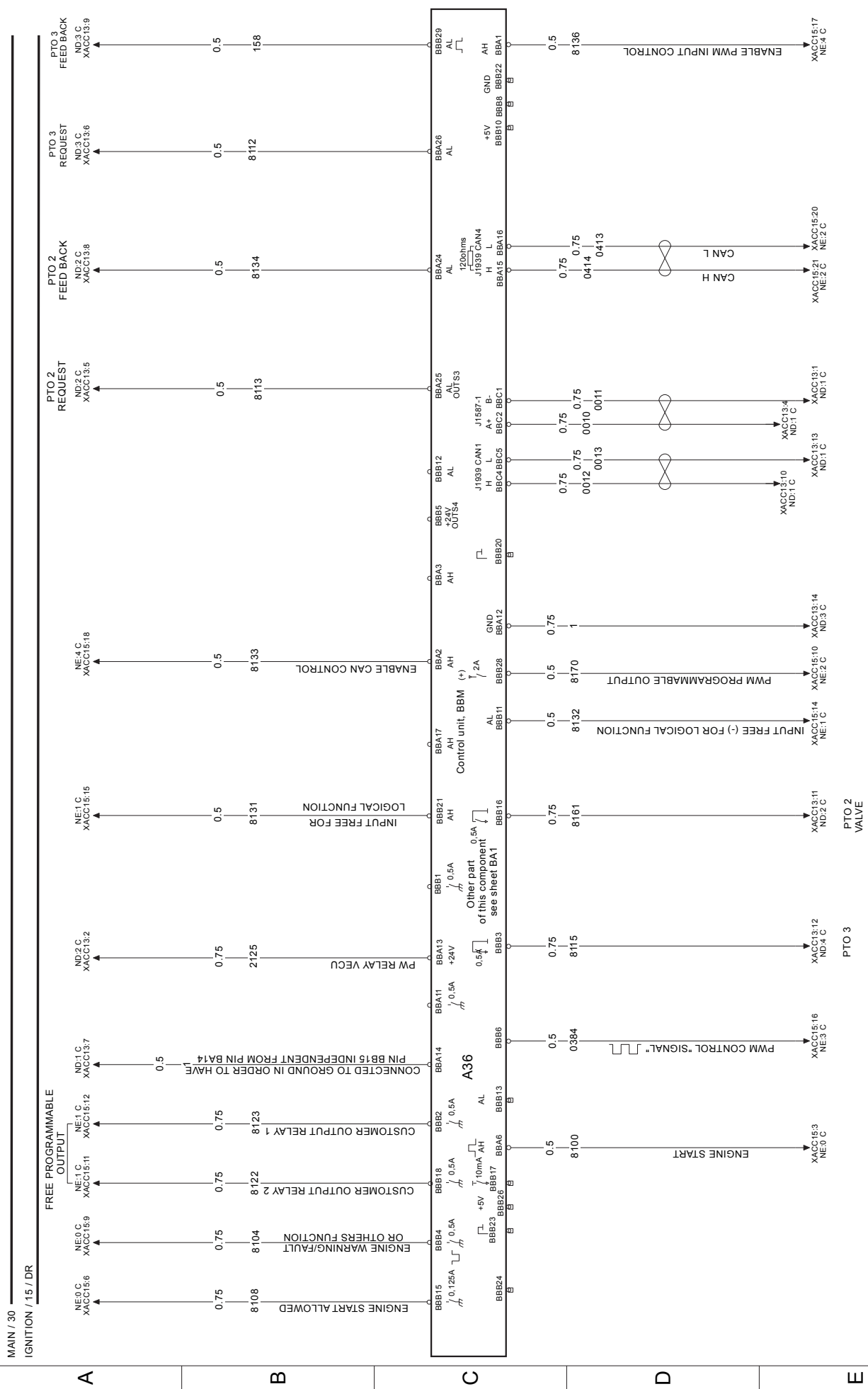

HIOM

WIRING DIAGRAM IO1_Hyb

4

3

2

1

0

MAIN / 30

IGNITION / 15

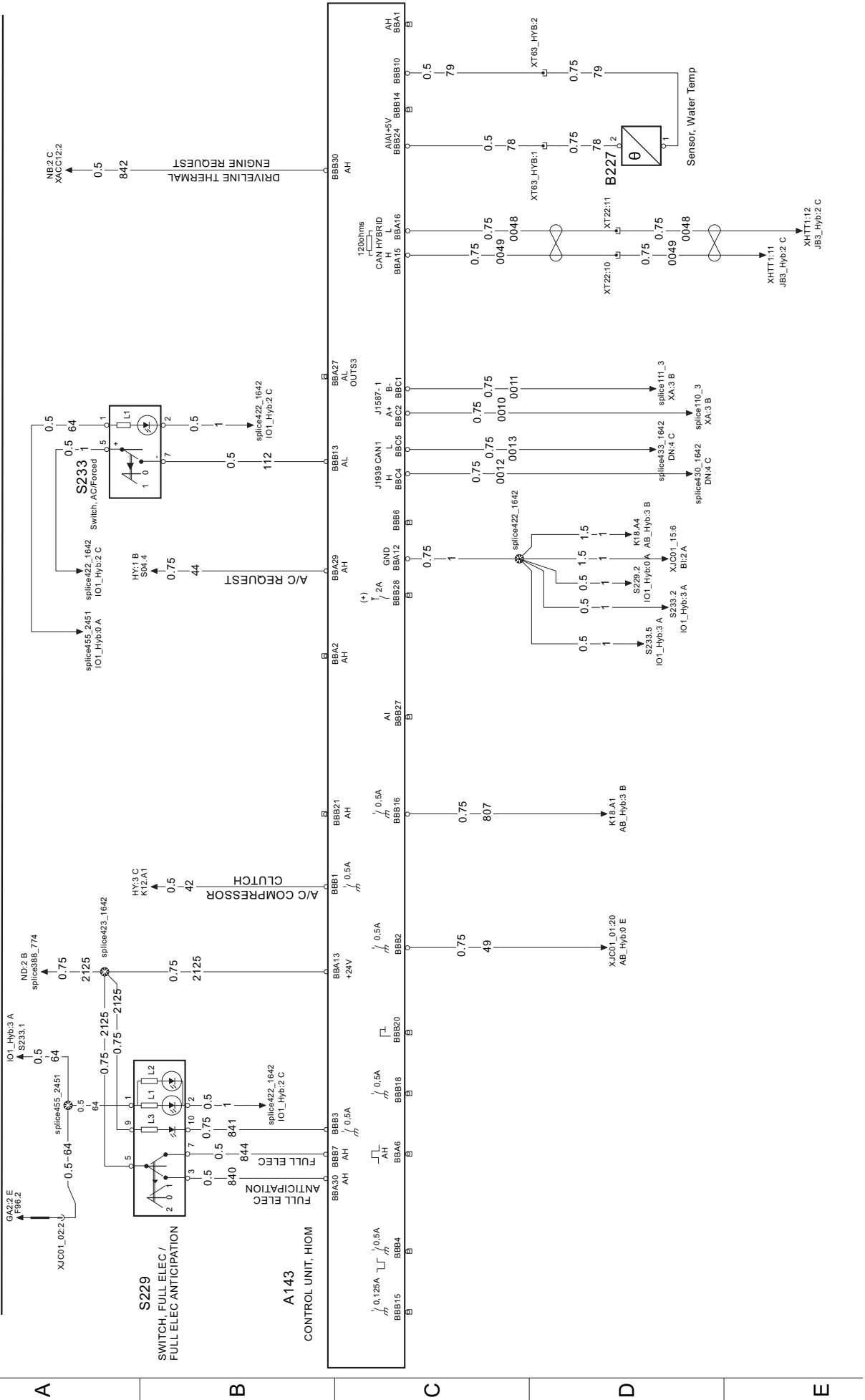

WIRING DIAGRAM IR

12 V power supply

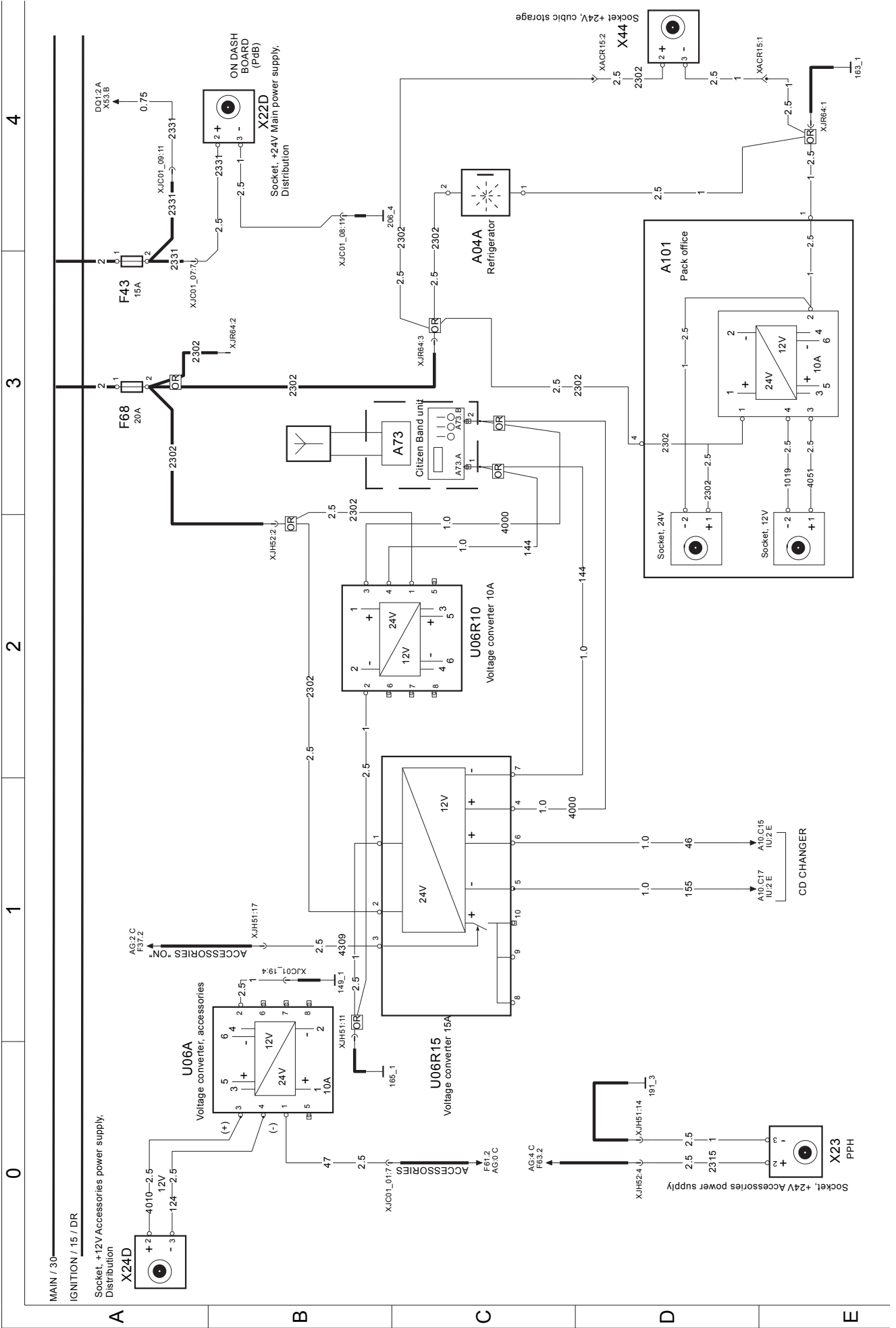

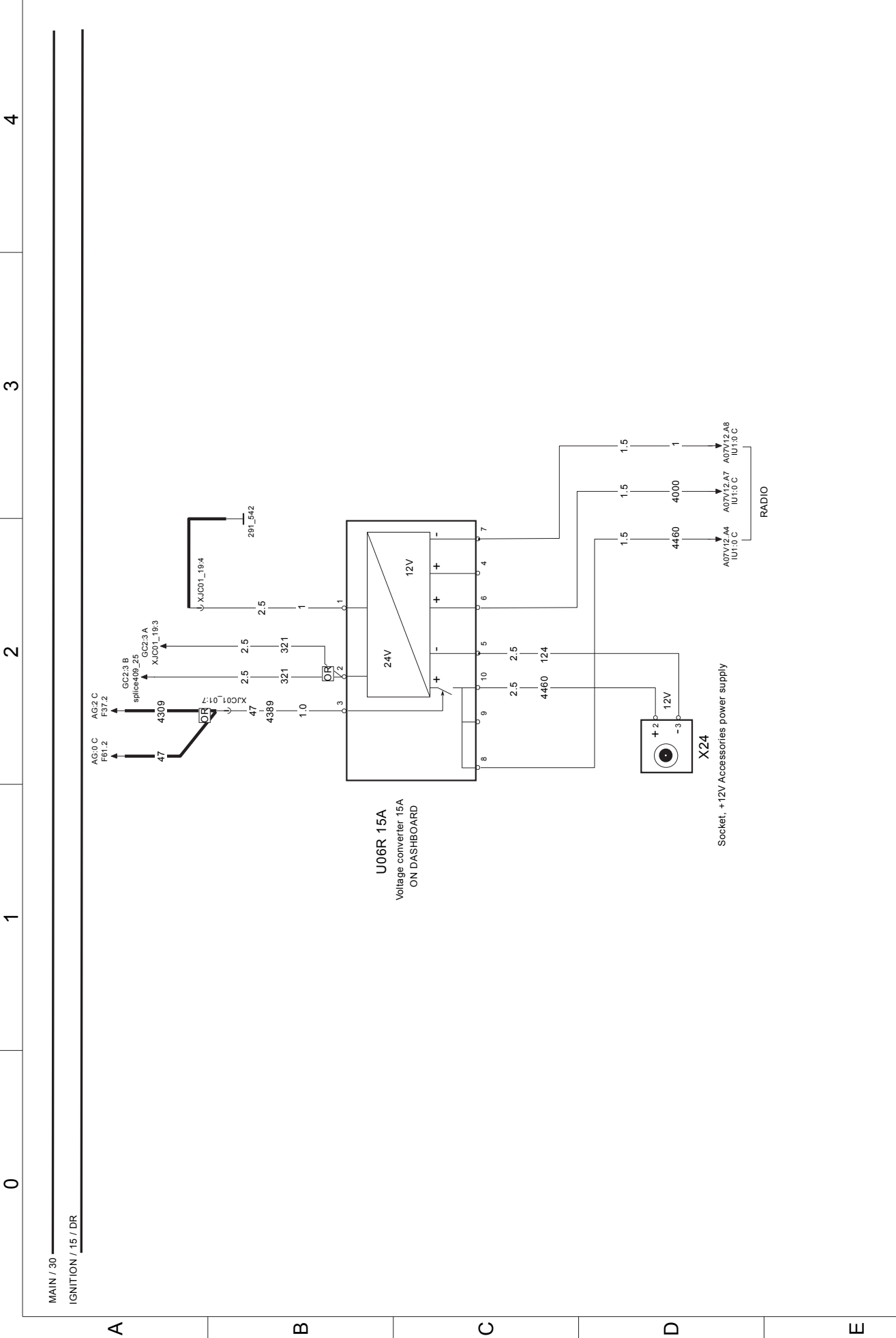

Radio (Before w837)

WIRING DIAGRAM IU

4

3

2

1

0

MAIN / 30

IGNITION / 15 / DR

A

B

C

D

E

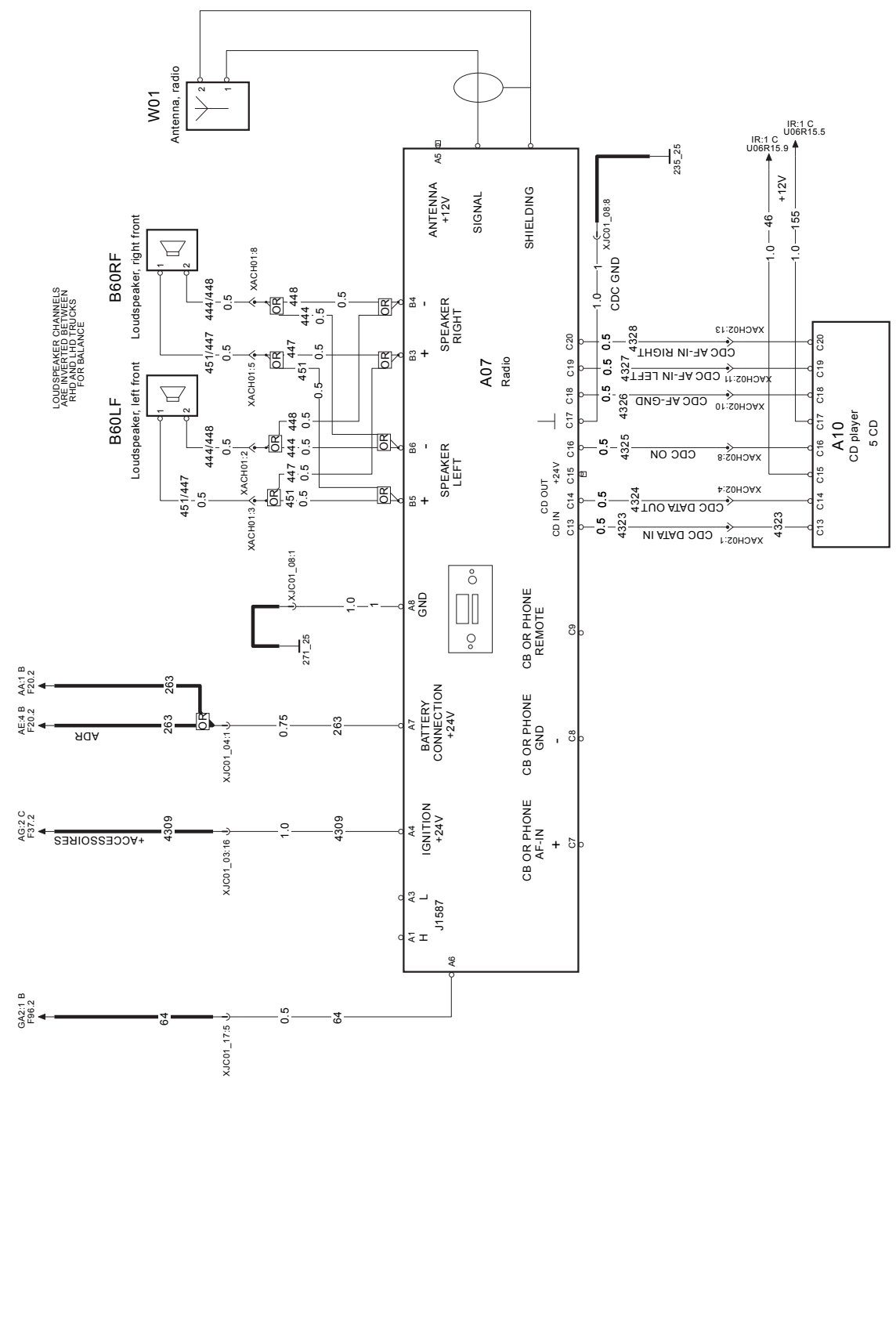

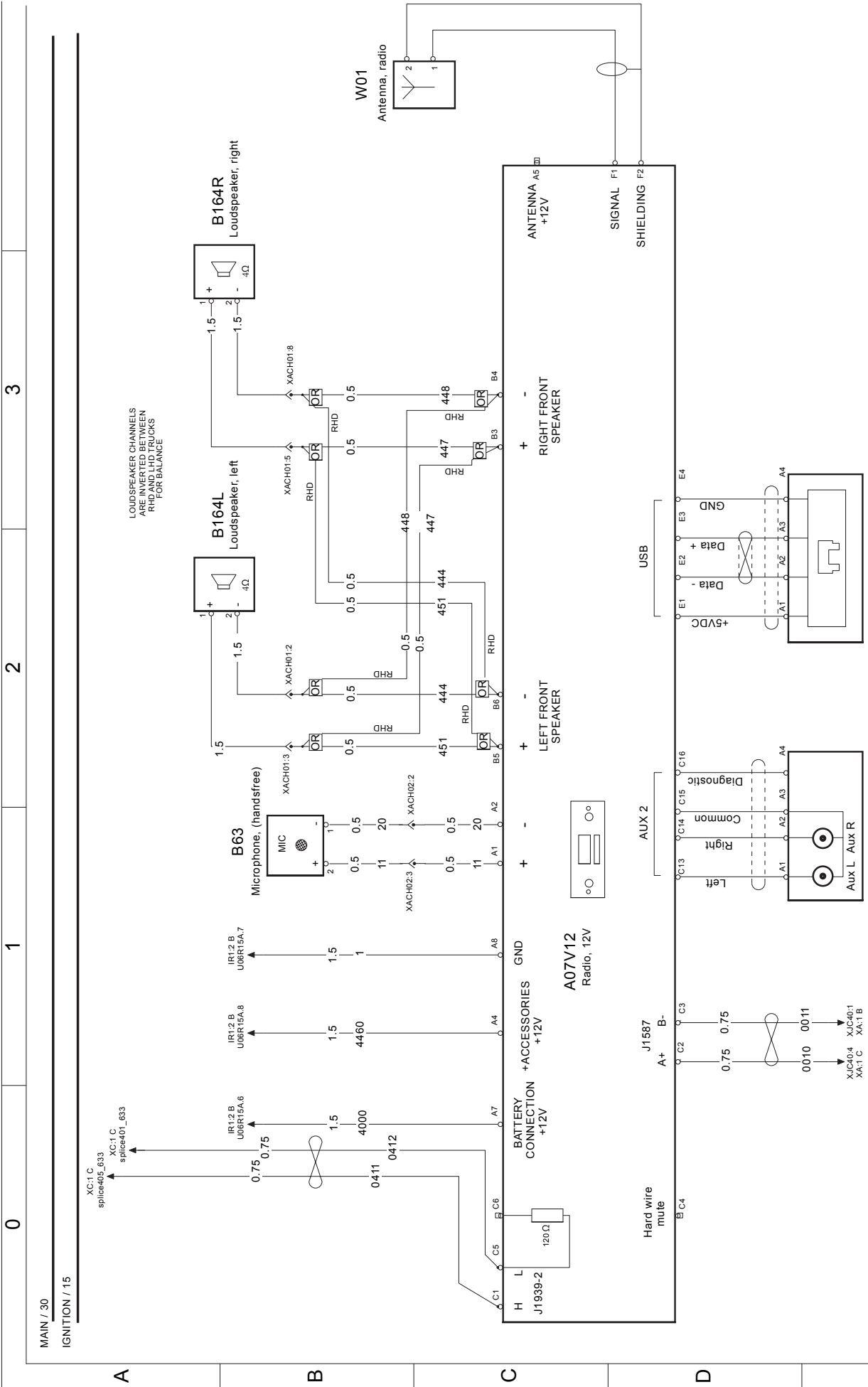

24V Junction Box Hybrid Area

WIRING DIAGRAM JB1_Hyb

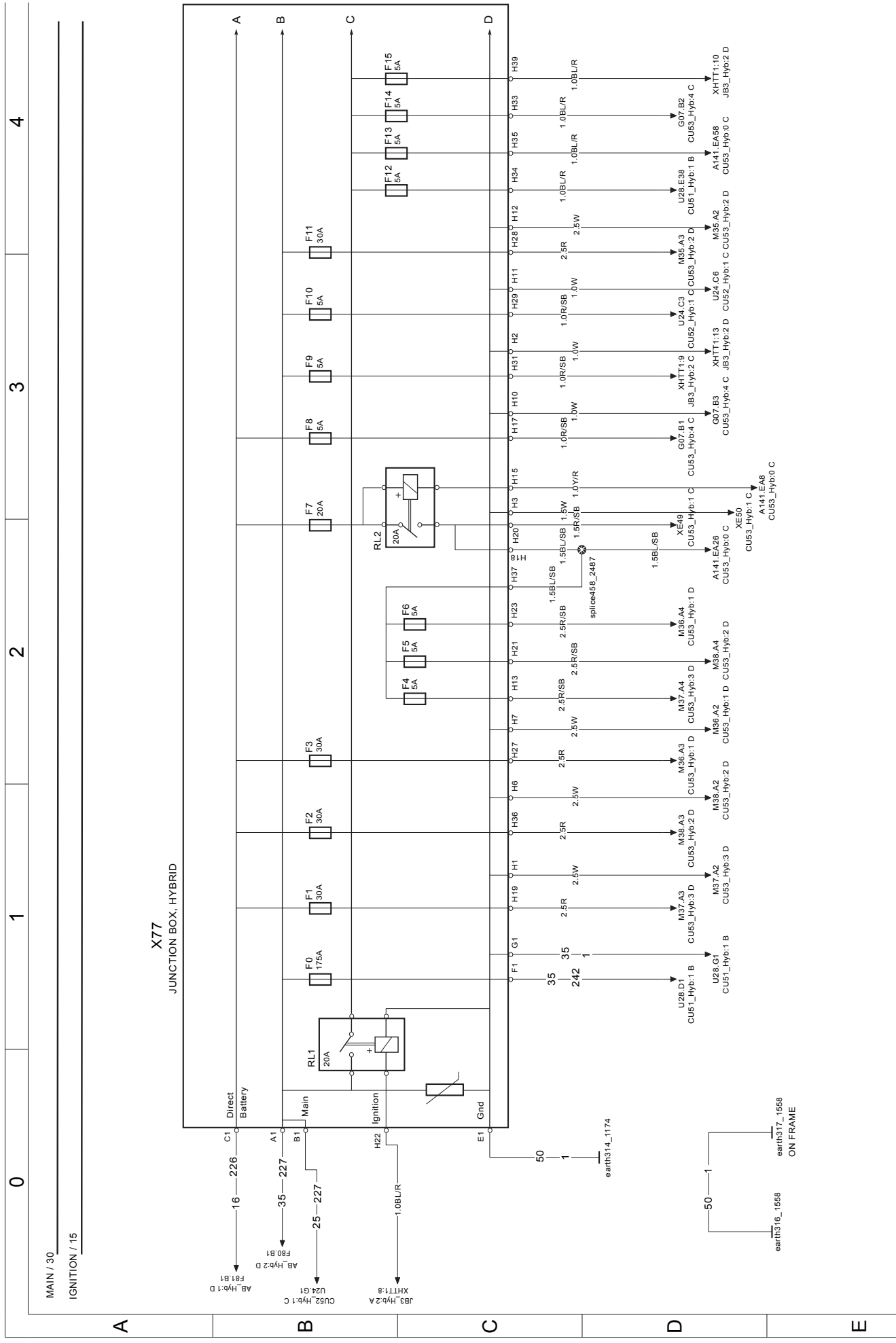

MAIN / 30
IGNITION / 15

A

B

C

D

E

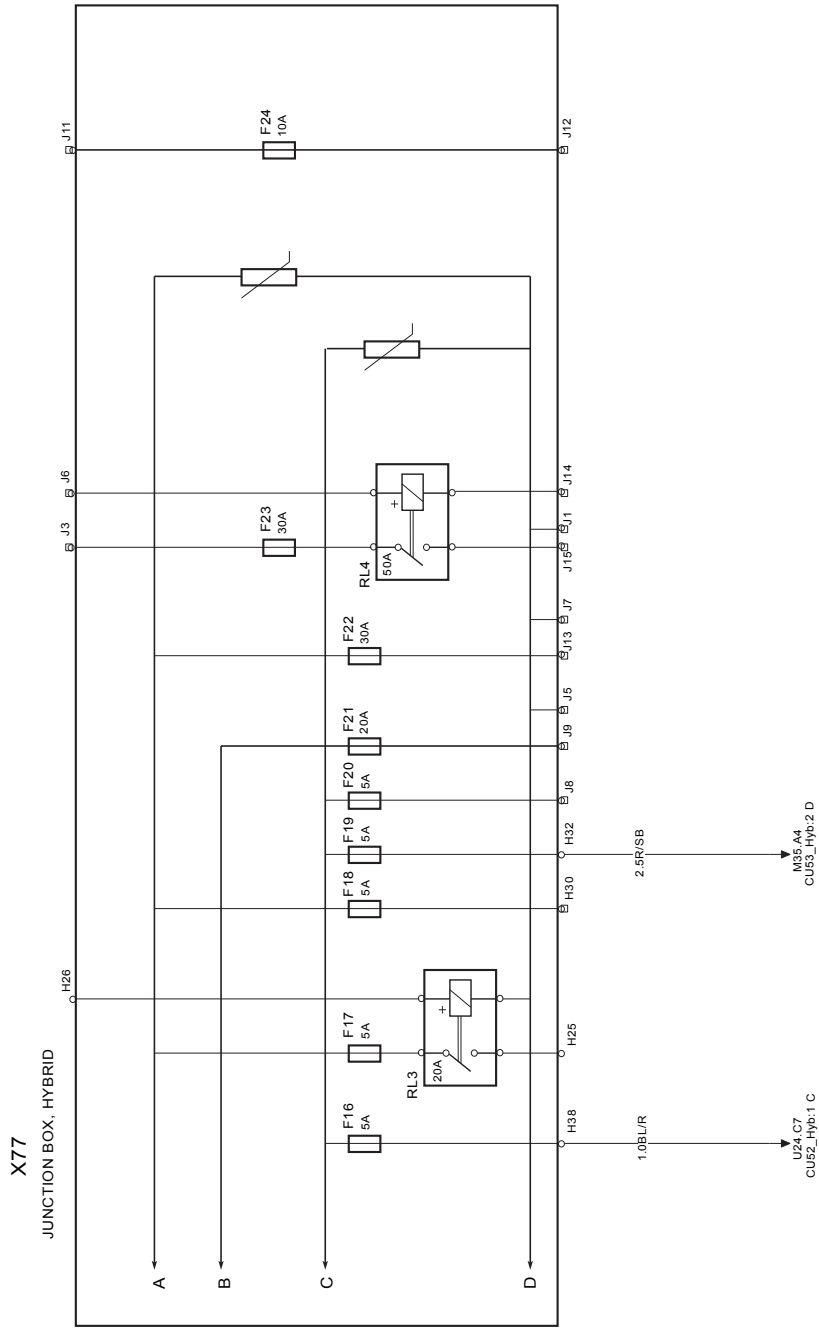

0

1

2

3

4

MAIN / 30

IGNITION / 15

HIC

Other part
of this component
see sheet JB3_Hyb

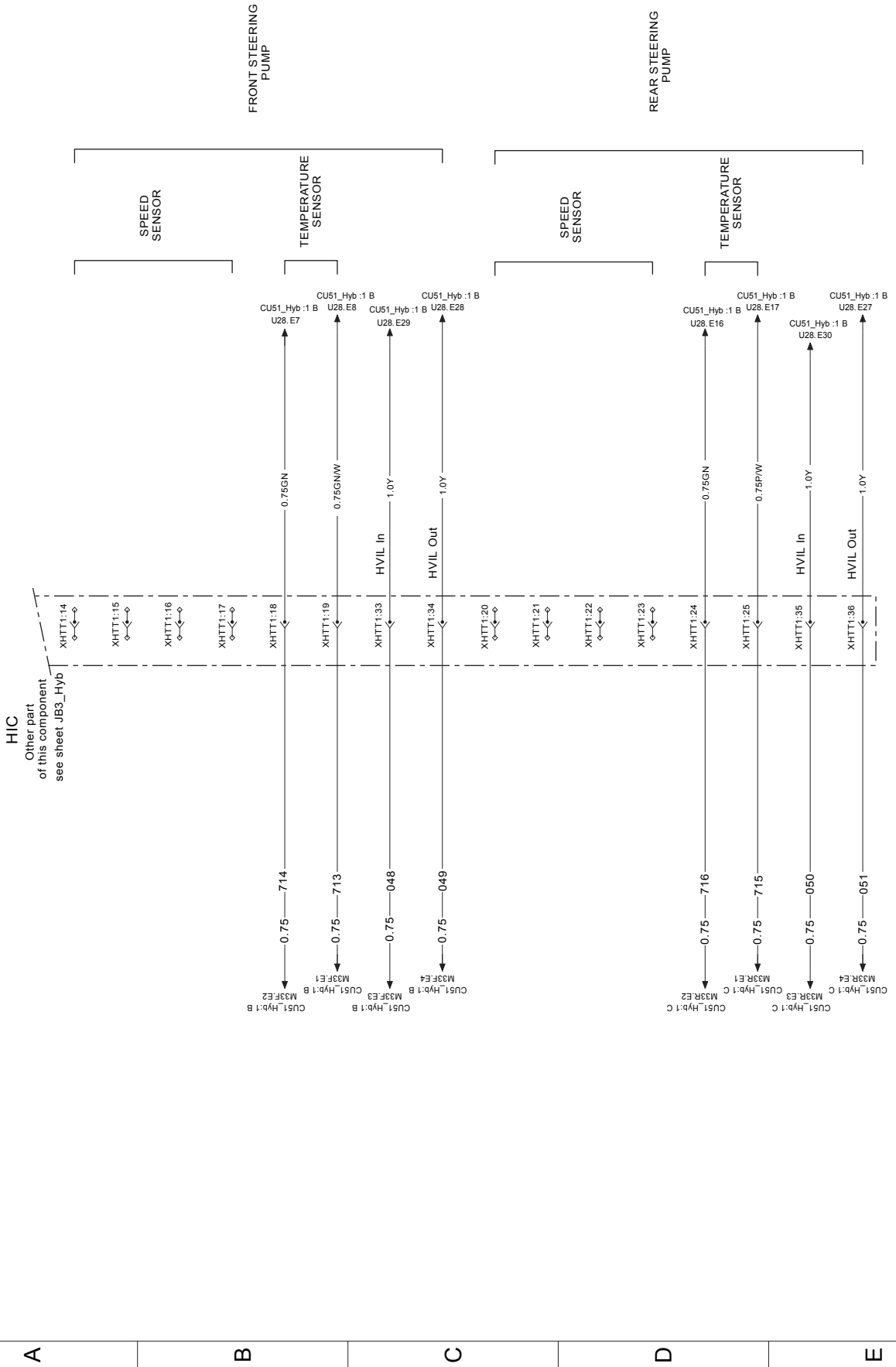

Ground bar/Radiators and Grid Hybrid Area

WIRING DIAGRAM JB5_Hyb

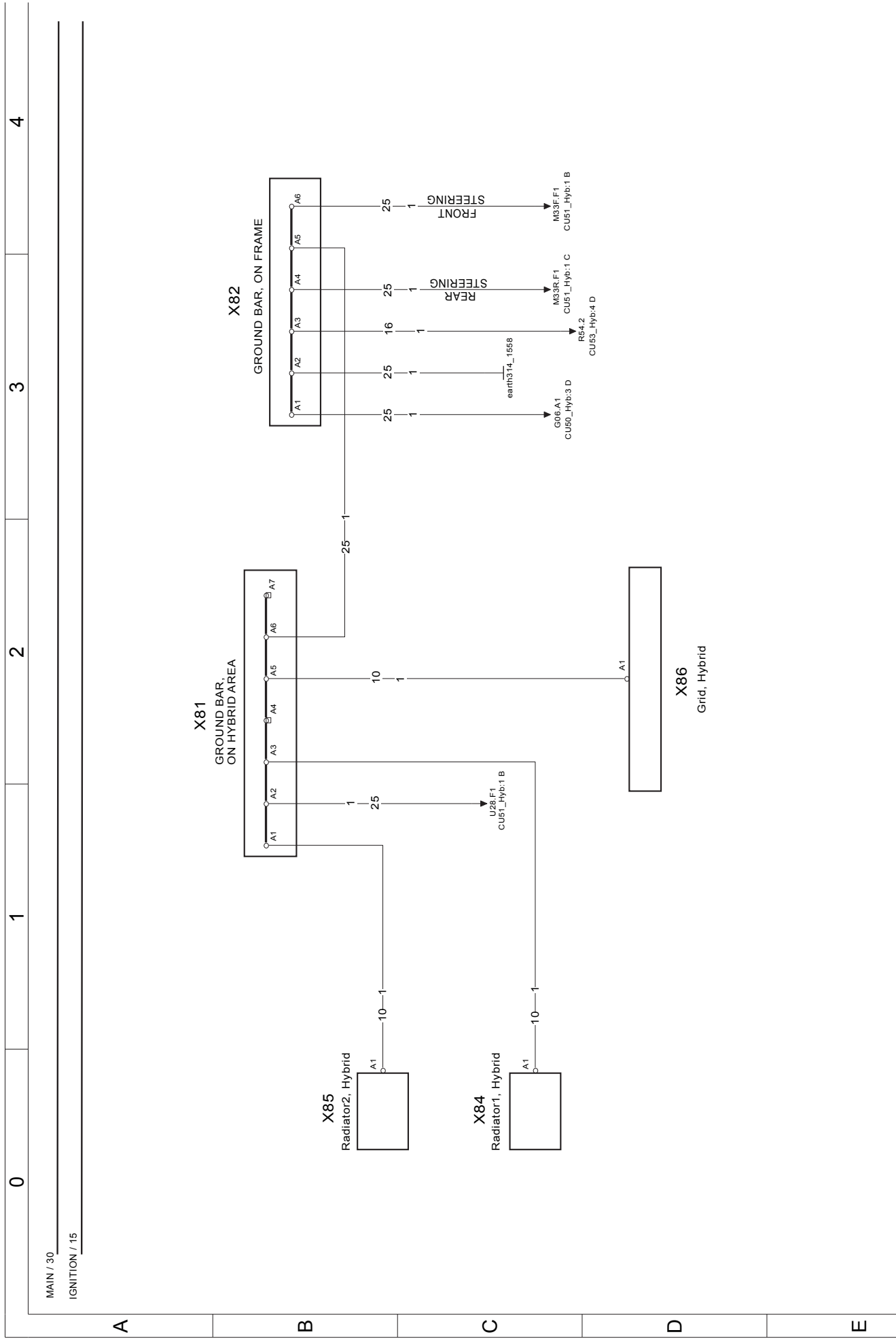

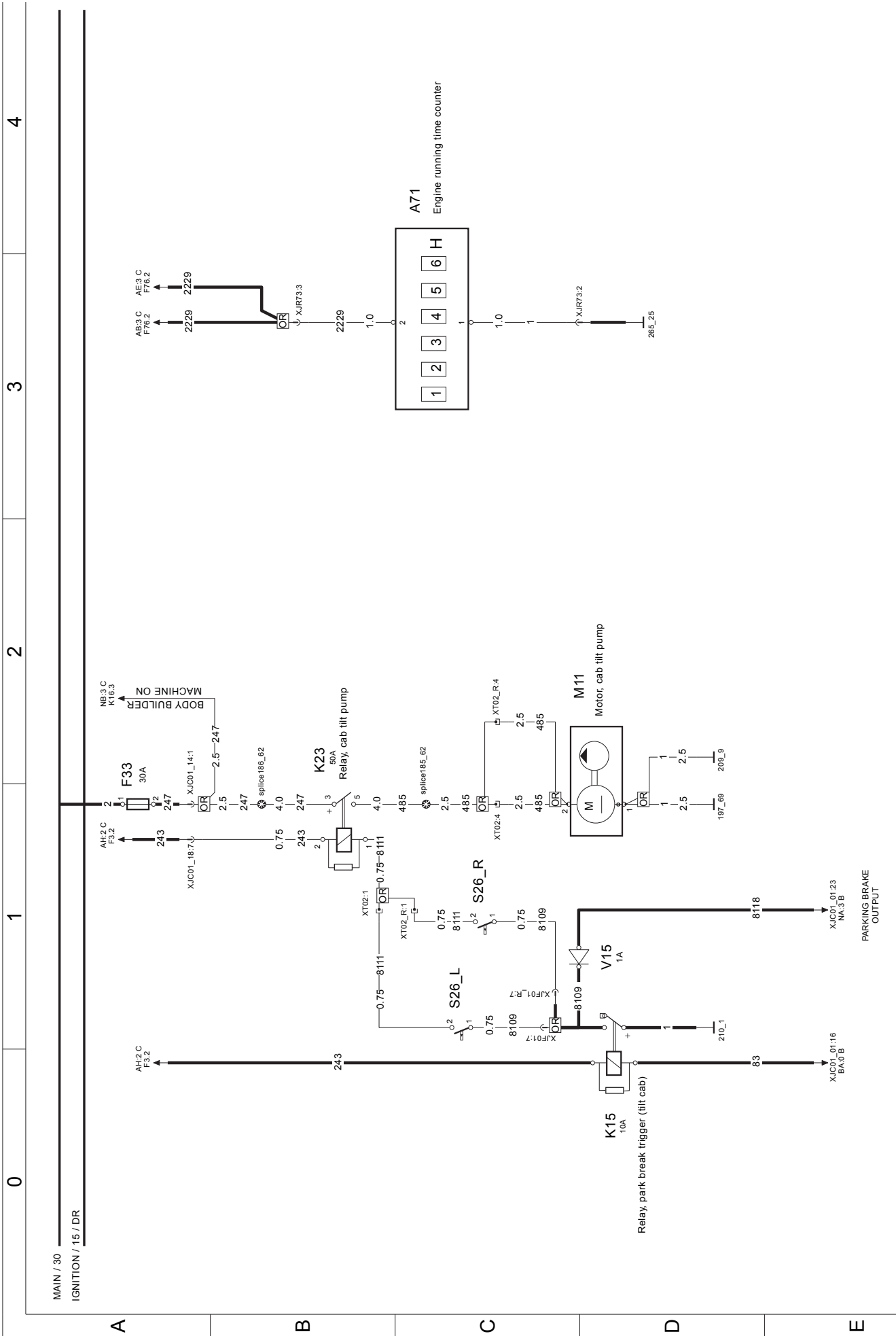

Body builder connector PB3 WIRING DIAGRAM NC

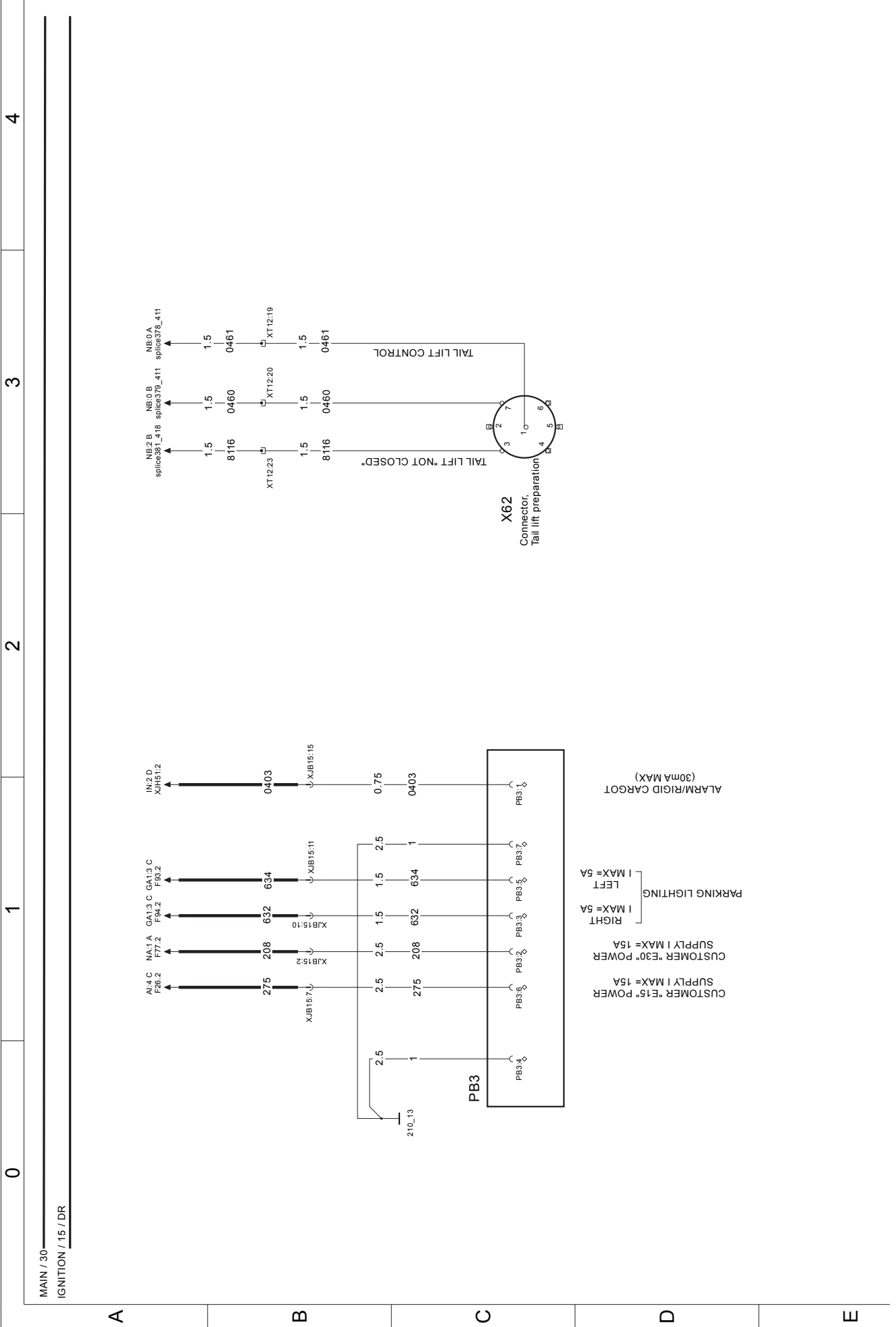

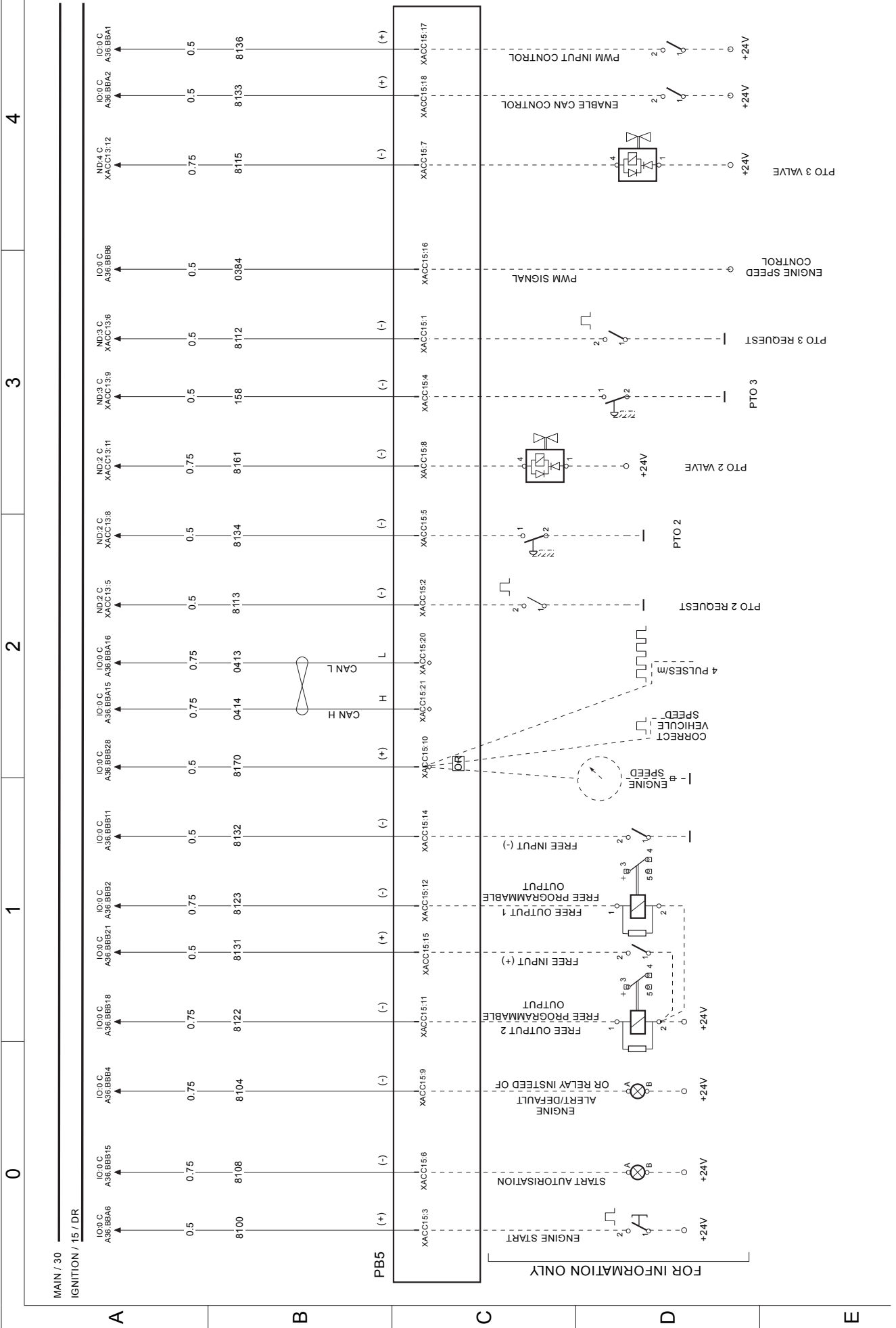

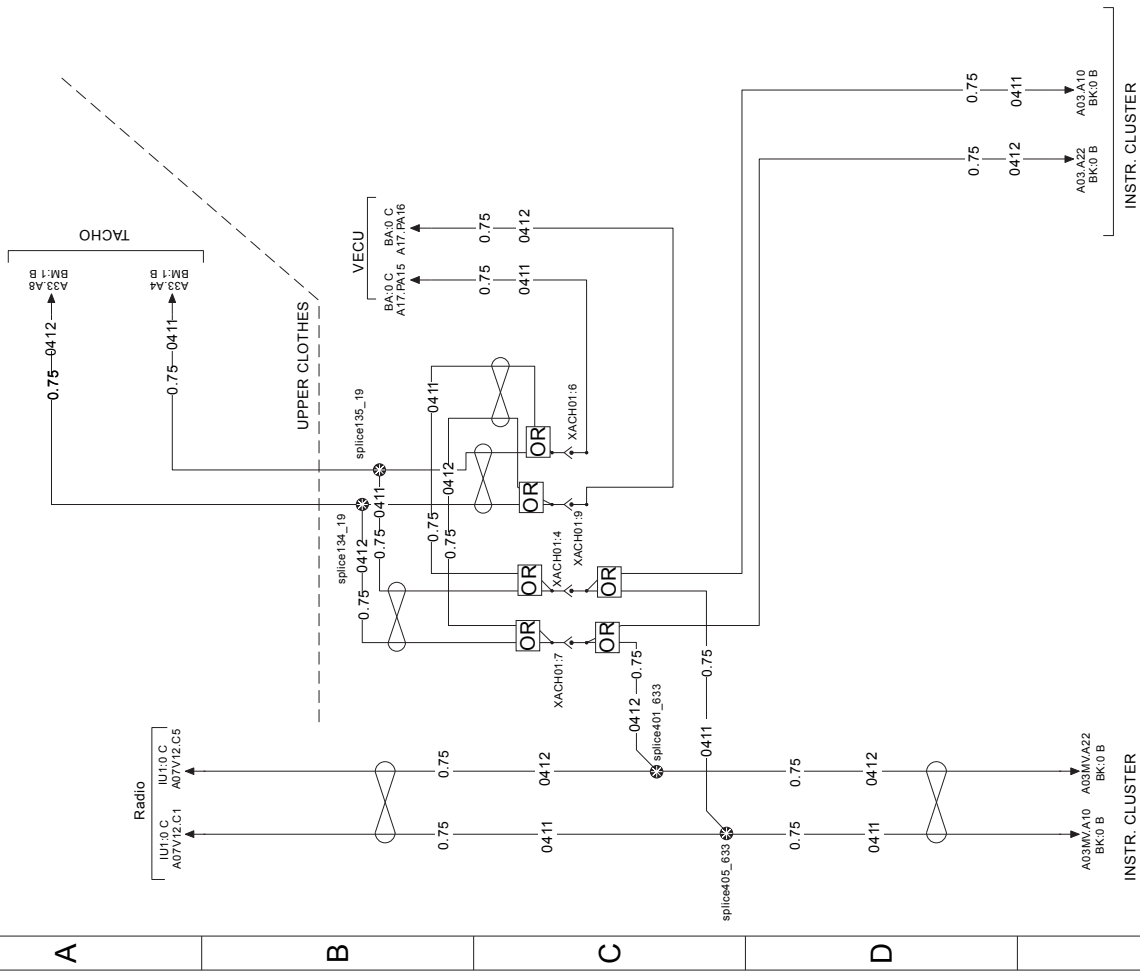

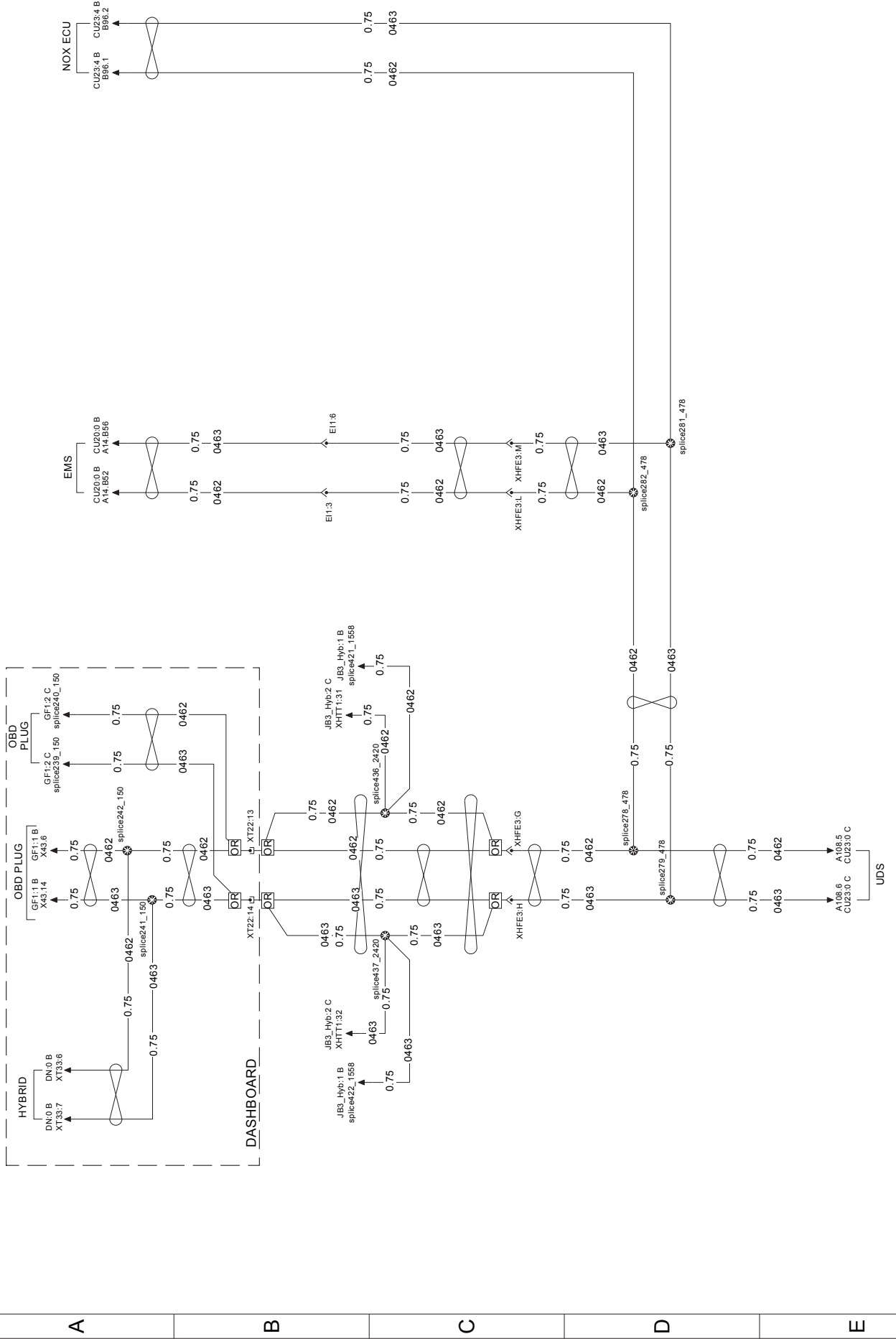

Illustrations index

-	Antenna	“” , page 97
-	Battery cables	“” , page 98
-	Cab inlets	“” , page 102
-	ECU in cab	“” , page 103
-	Electrical junction box.....	“” , page 104
-	Switches	“” , page 108
1000	Wiring harness, instruments.....	“” , page 110
1006	Wiring harness, roof	“” , page 115
1007	Wiring harness, floor	“” , page 119
1030	Wiring harness, engine	“” , page 121
1040	Wiring harness, frame	“” , page 123
1047	Wiring harness, roof beacon light	“” , page 129
1057	Wiring harness, chassis	“” , page 130
1063	Wiring harness, trailer connections.....	“” , page 134
1083	Wiring harness, door	“” , page 137
1435	Wiring harness, main switch	“” , page 139
1447	Wiring harness, bumpers	“” , page 142
1460	Wiring harness, cab-battery box.....	“” , page 139
1494	Wiring harness, gearbox	“” , page 143
1499	Wiring harness, cab-gearbox.....	“” , page 143
1501	Wiring harness, upper front	“” , page 146

Illustrations

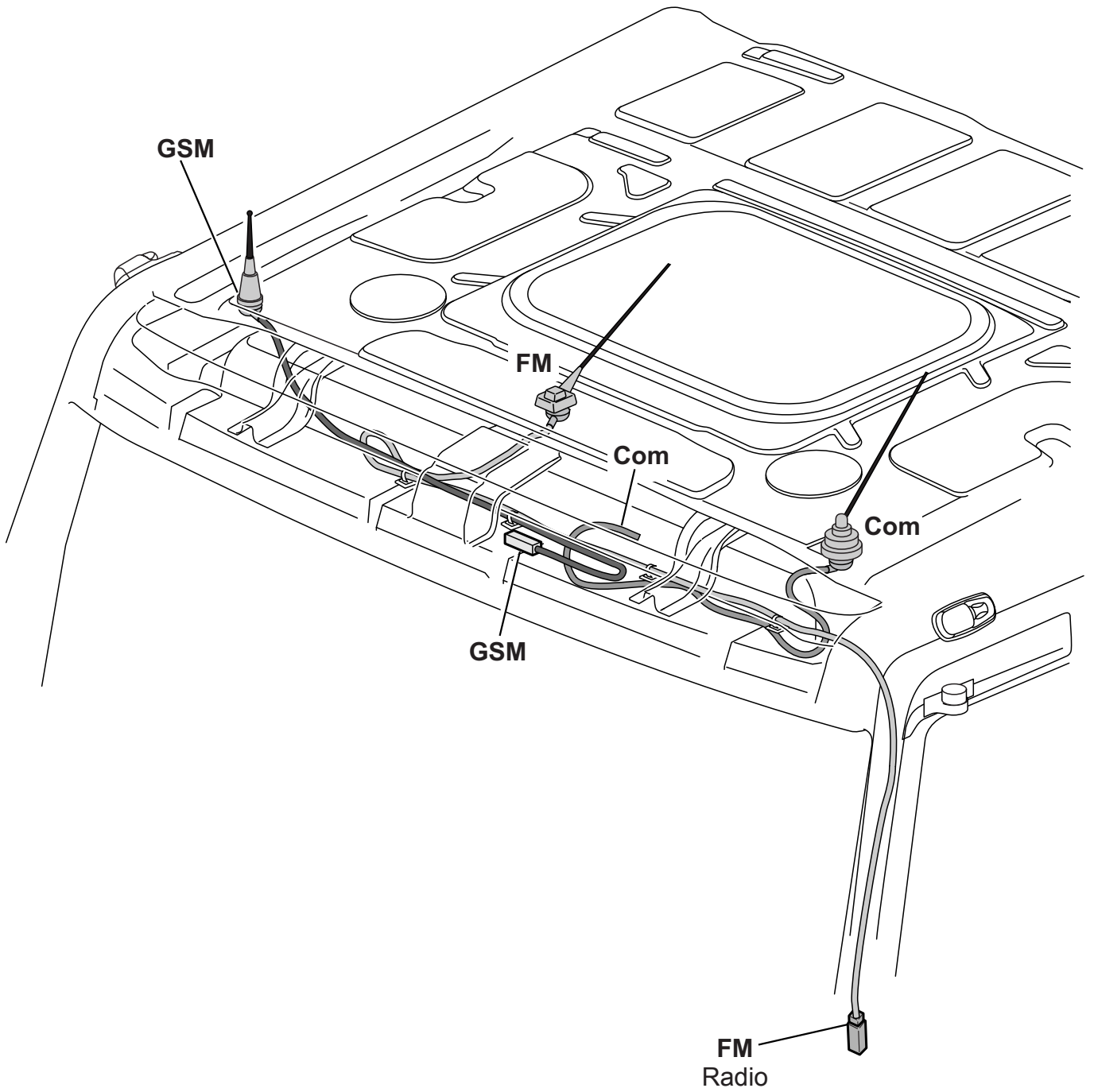

Battery Connections

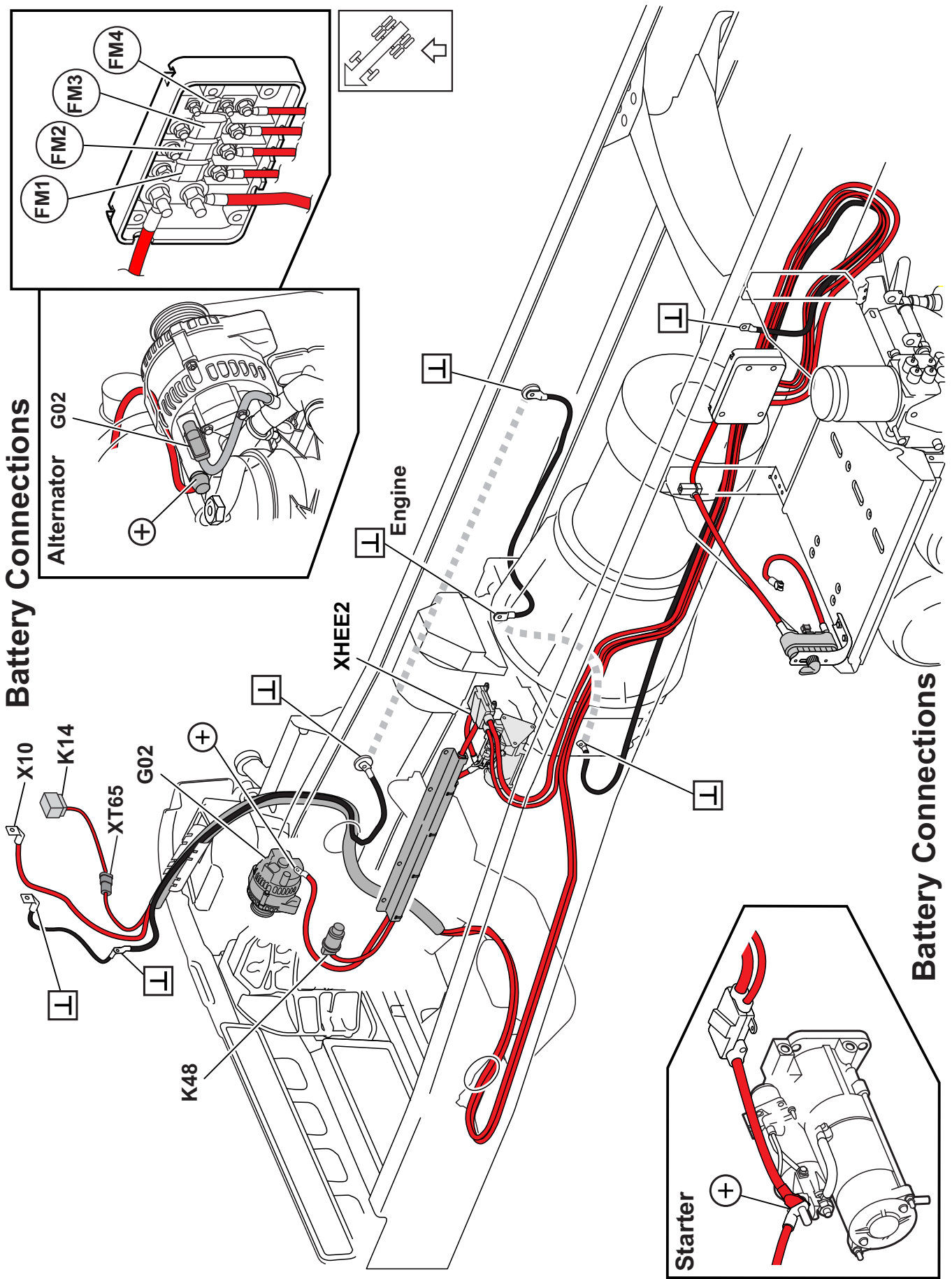

Battery Connections, Hybrid

Battery Connections, Hybrid

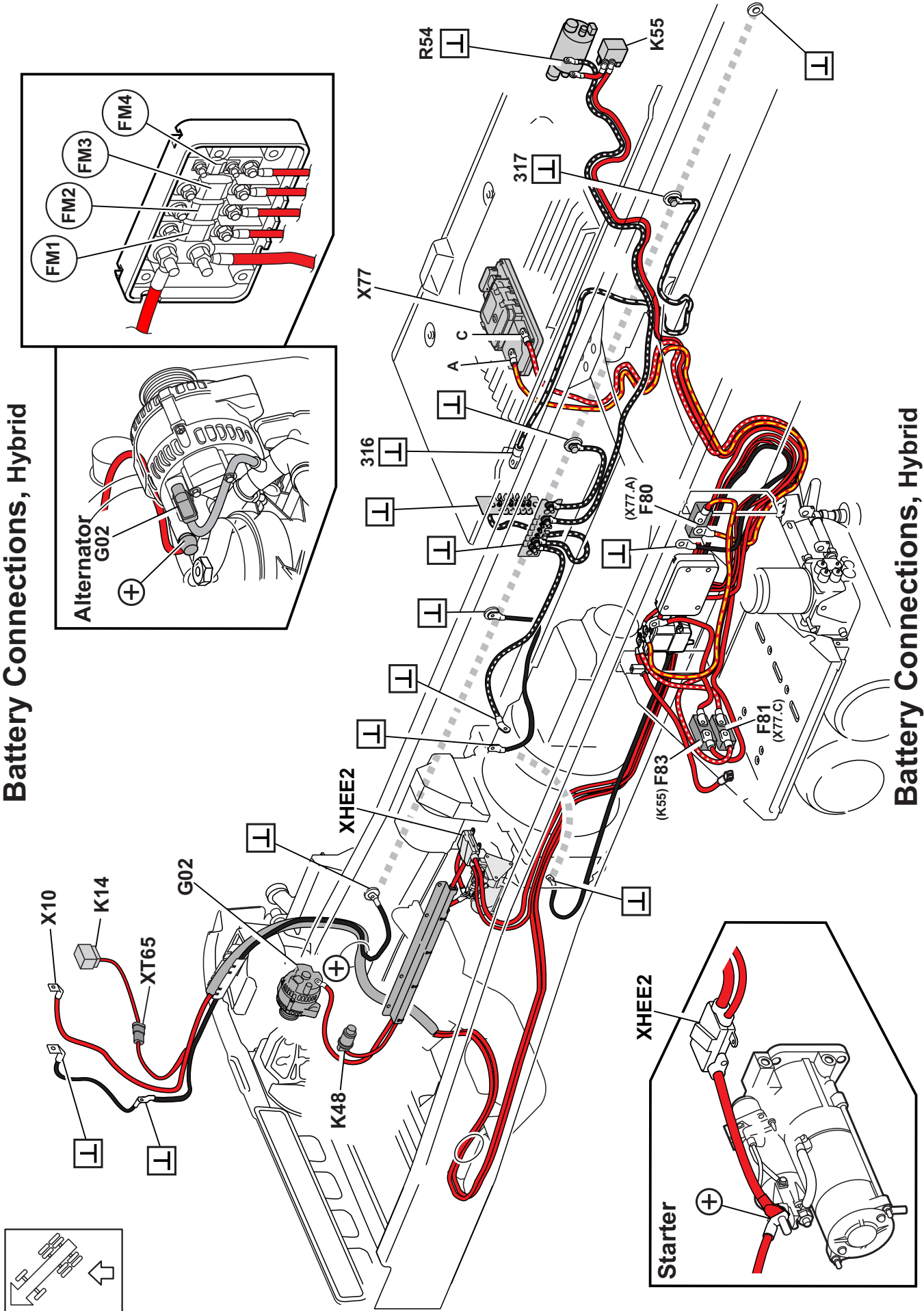

24V Power supply, Hybrid-box

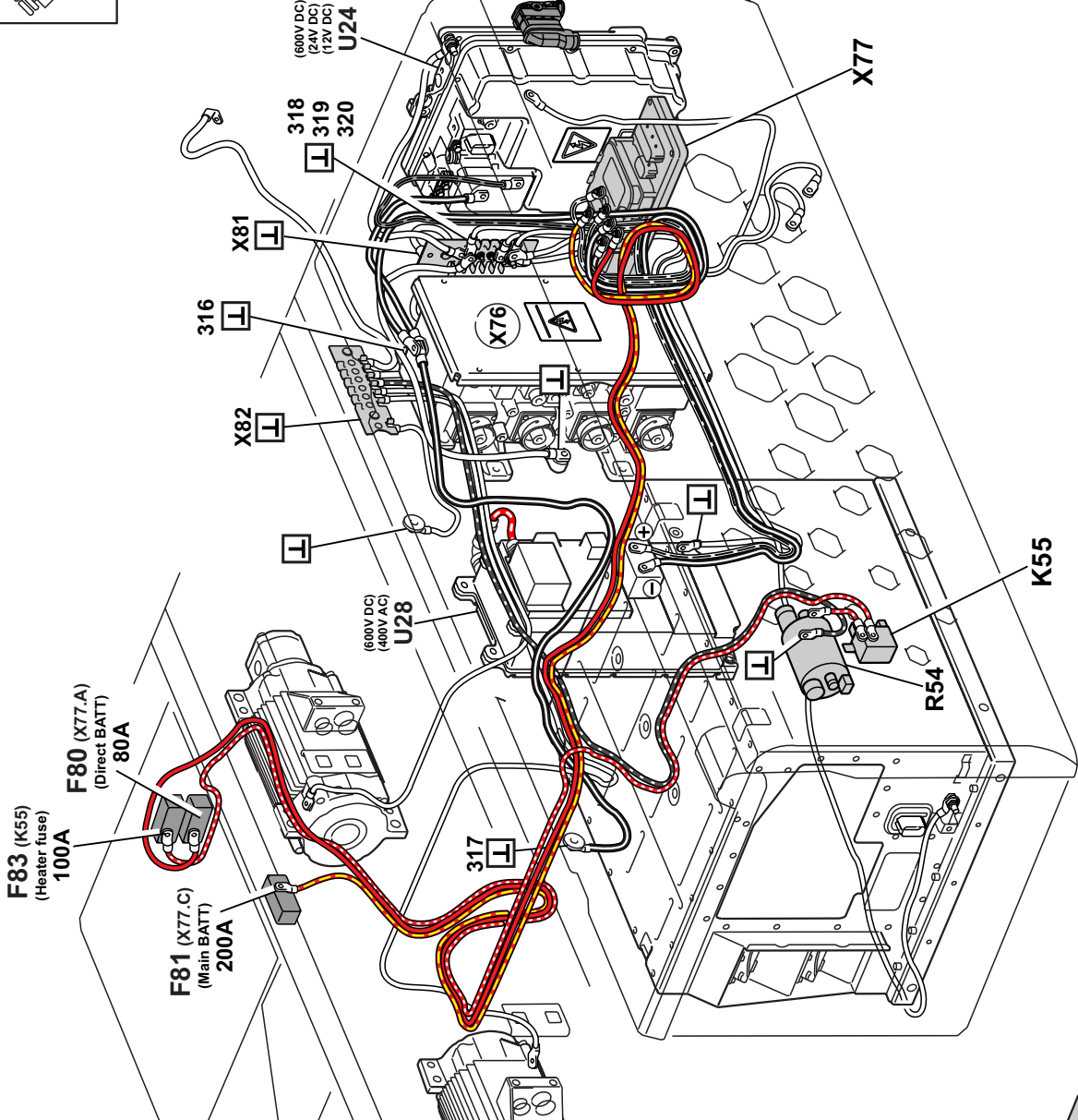
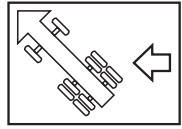

24V Power supply, Hybrid-box

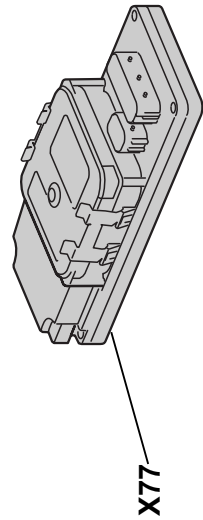
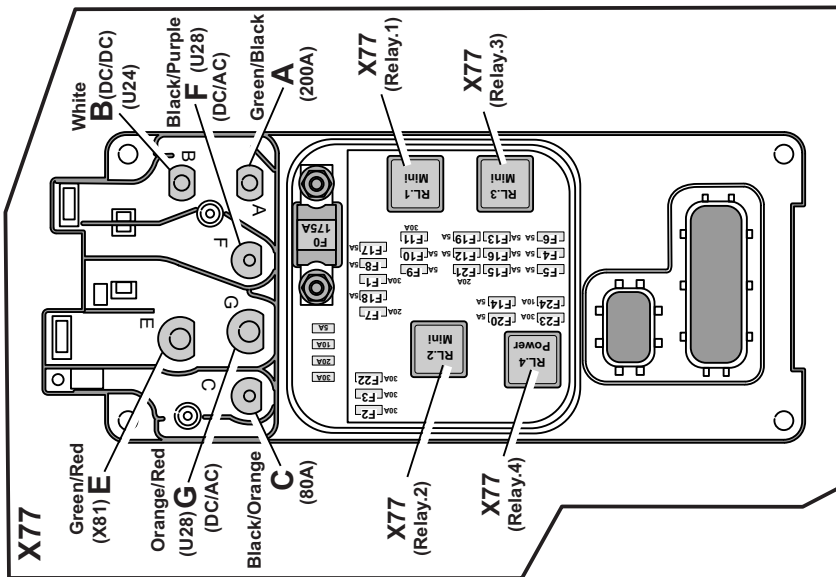

Hybrid-box, 600V DC, 400V AC

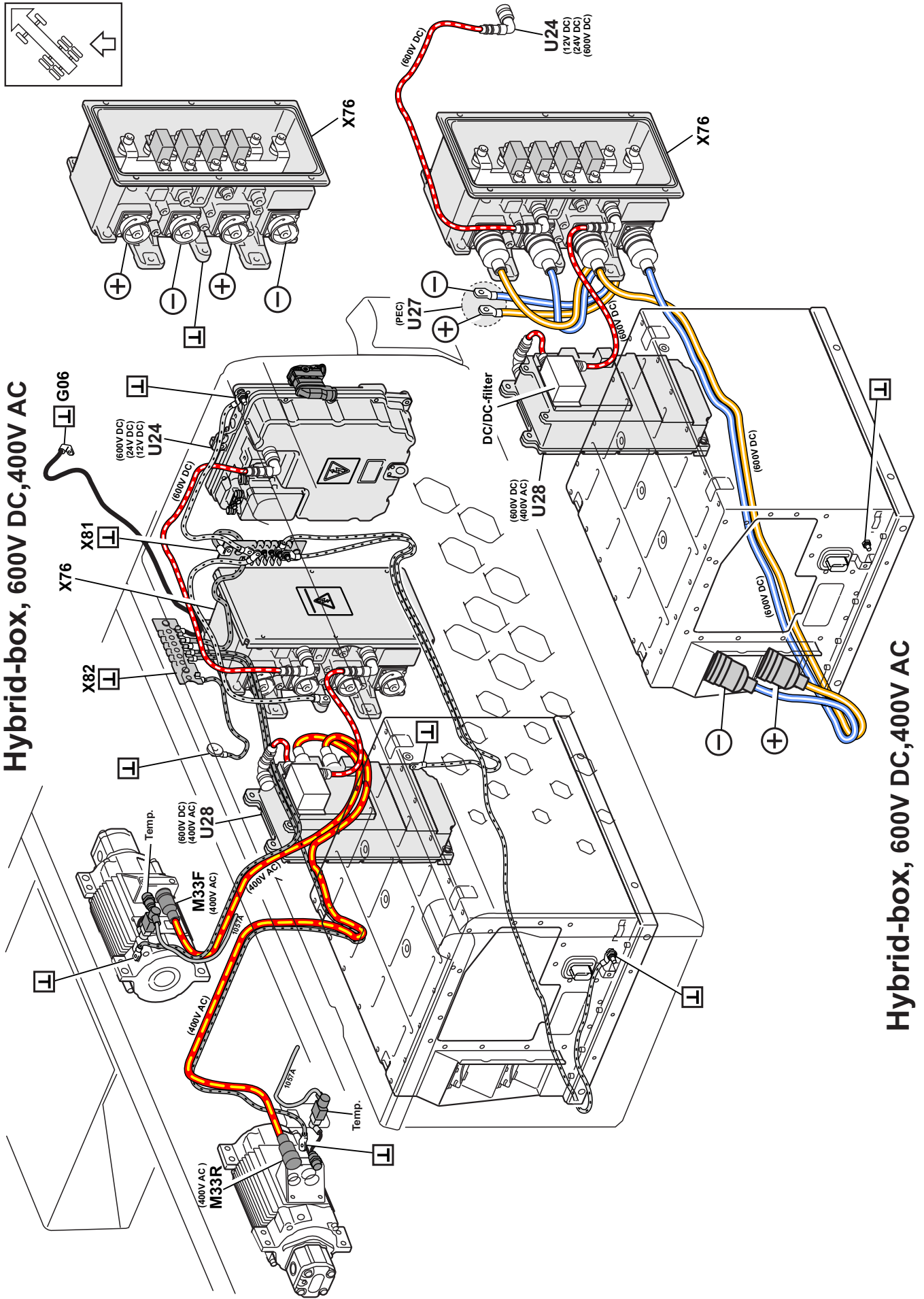

Hybrid-box, 600V DC, 400V AC

CAB Inlets

CAB Inlets

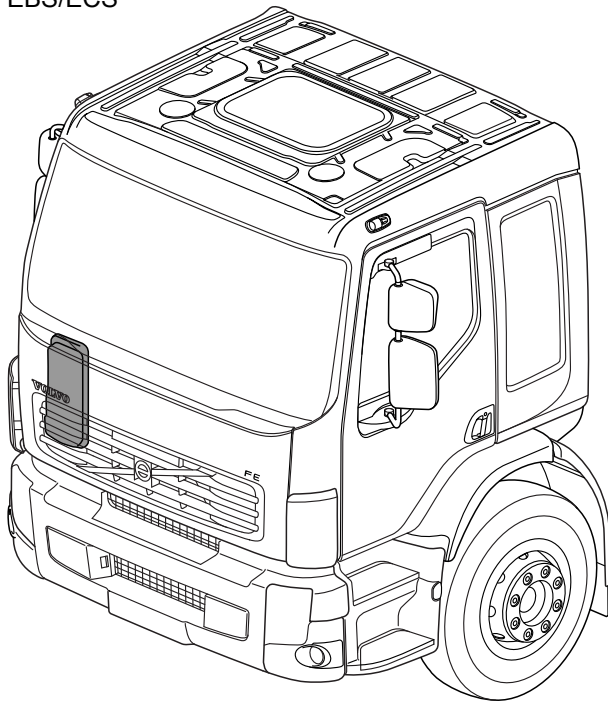
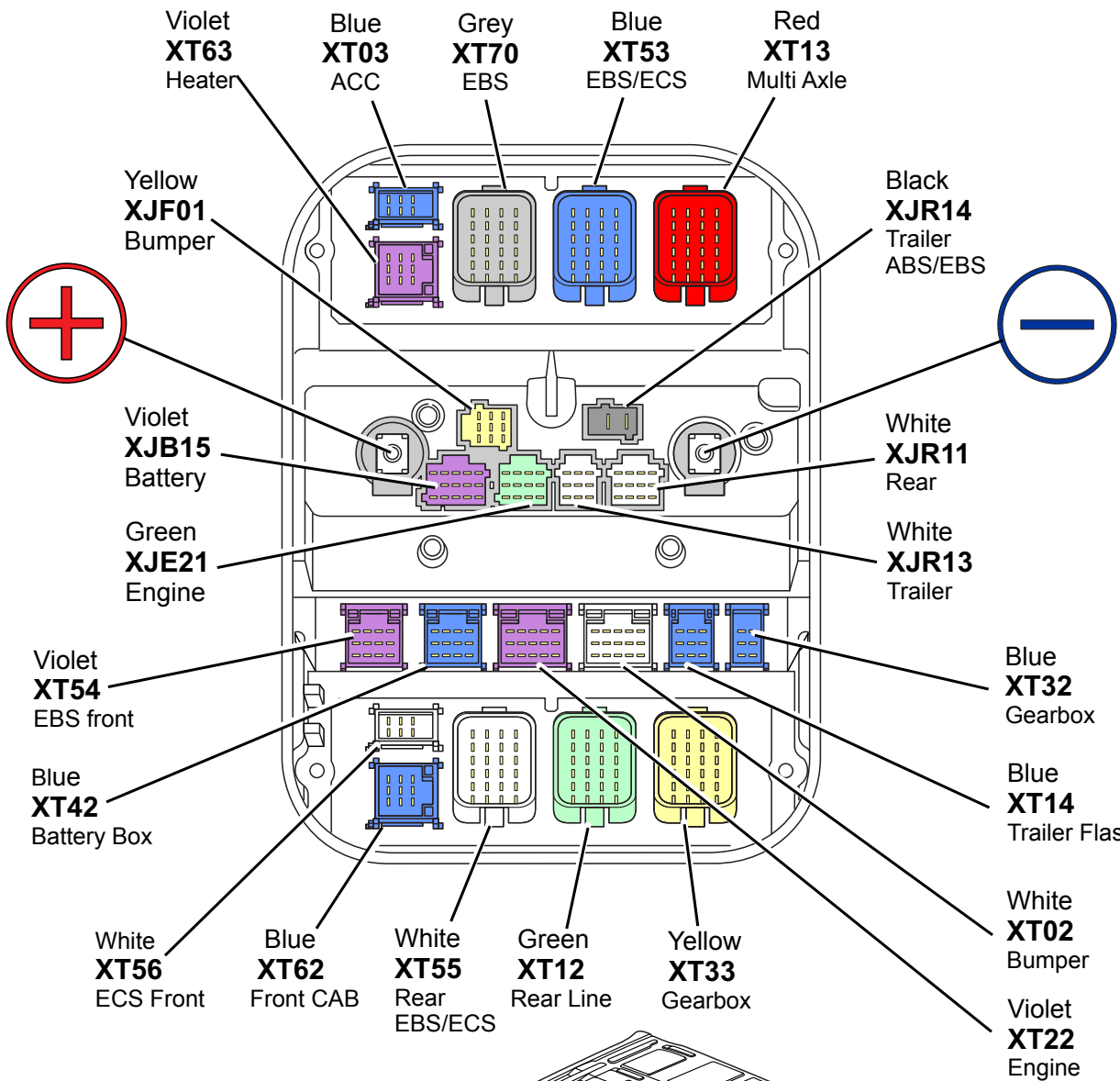

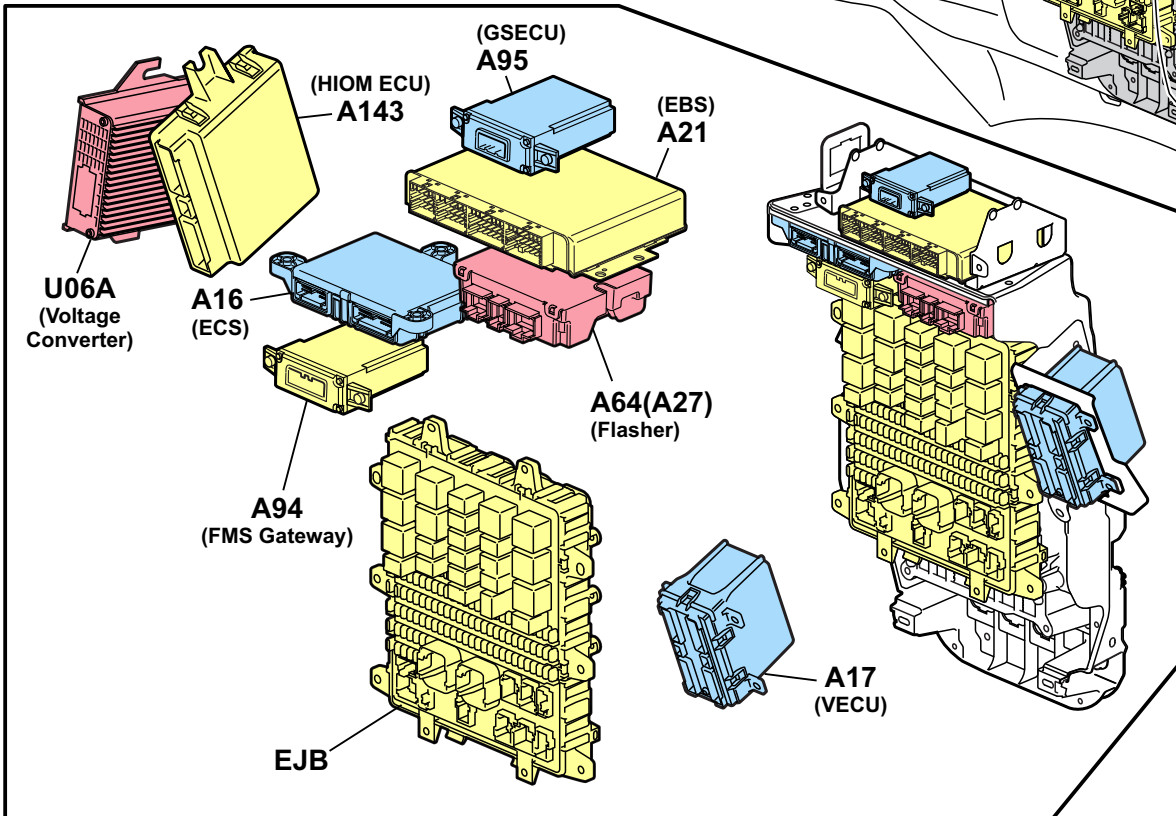
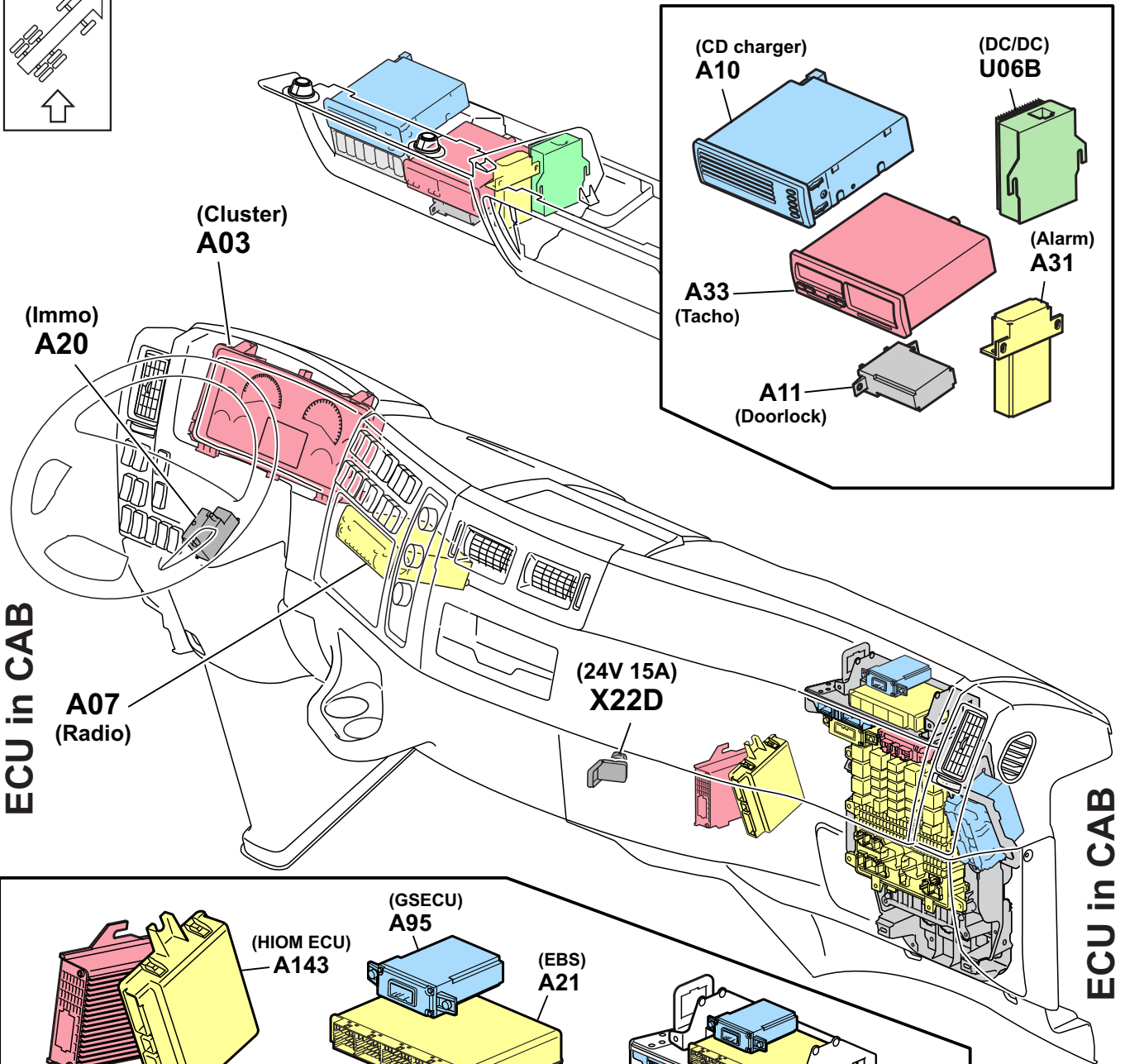
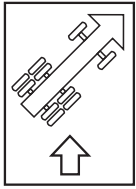

EJB, Electrical Junction Box

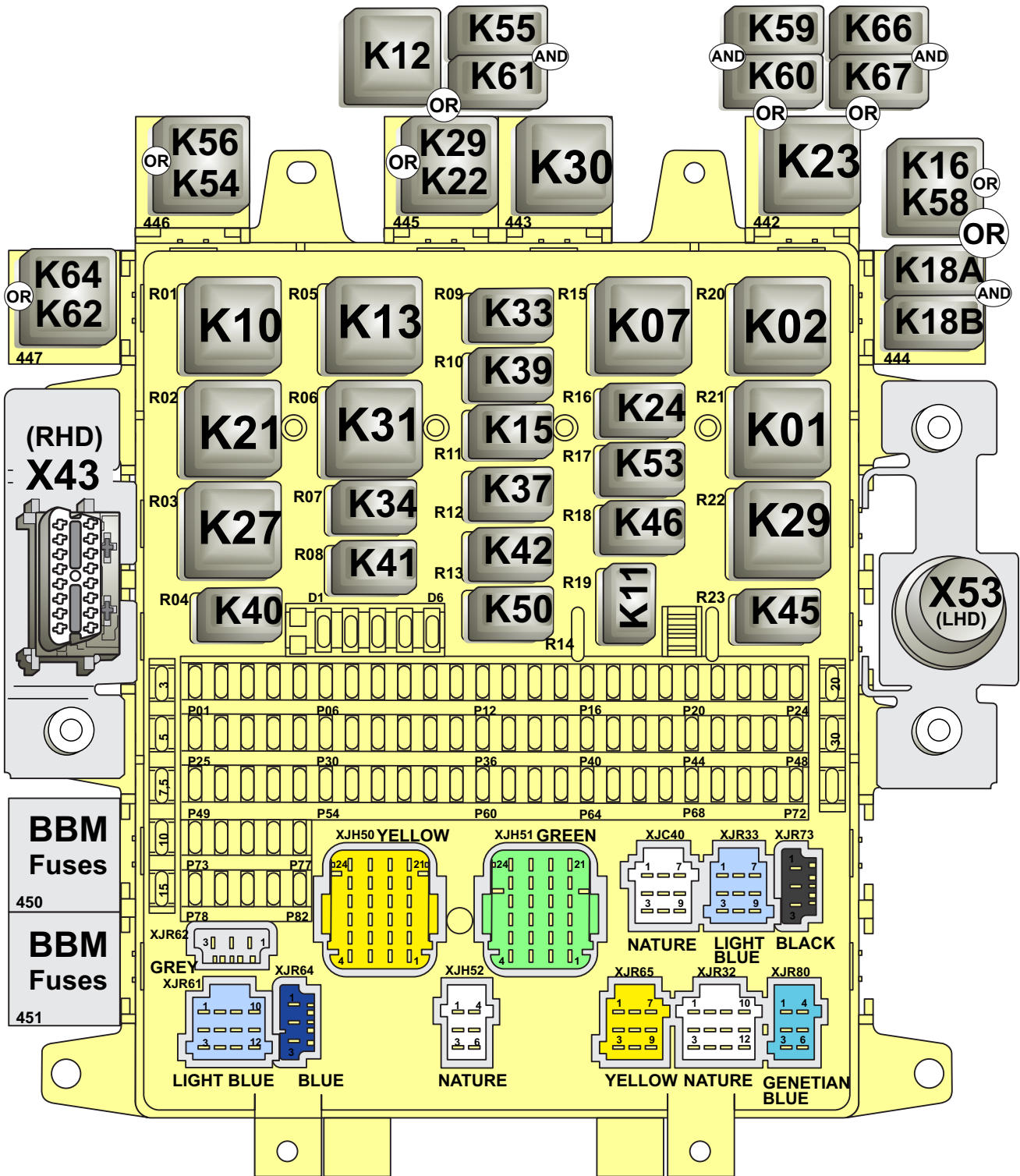

EJB, Electrical Junction Box

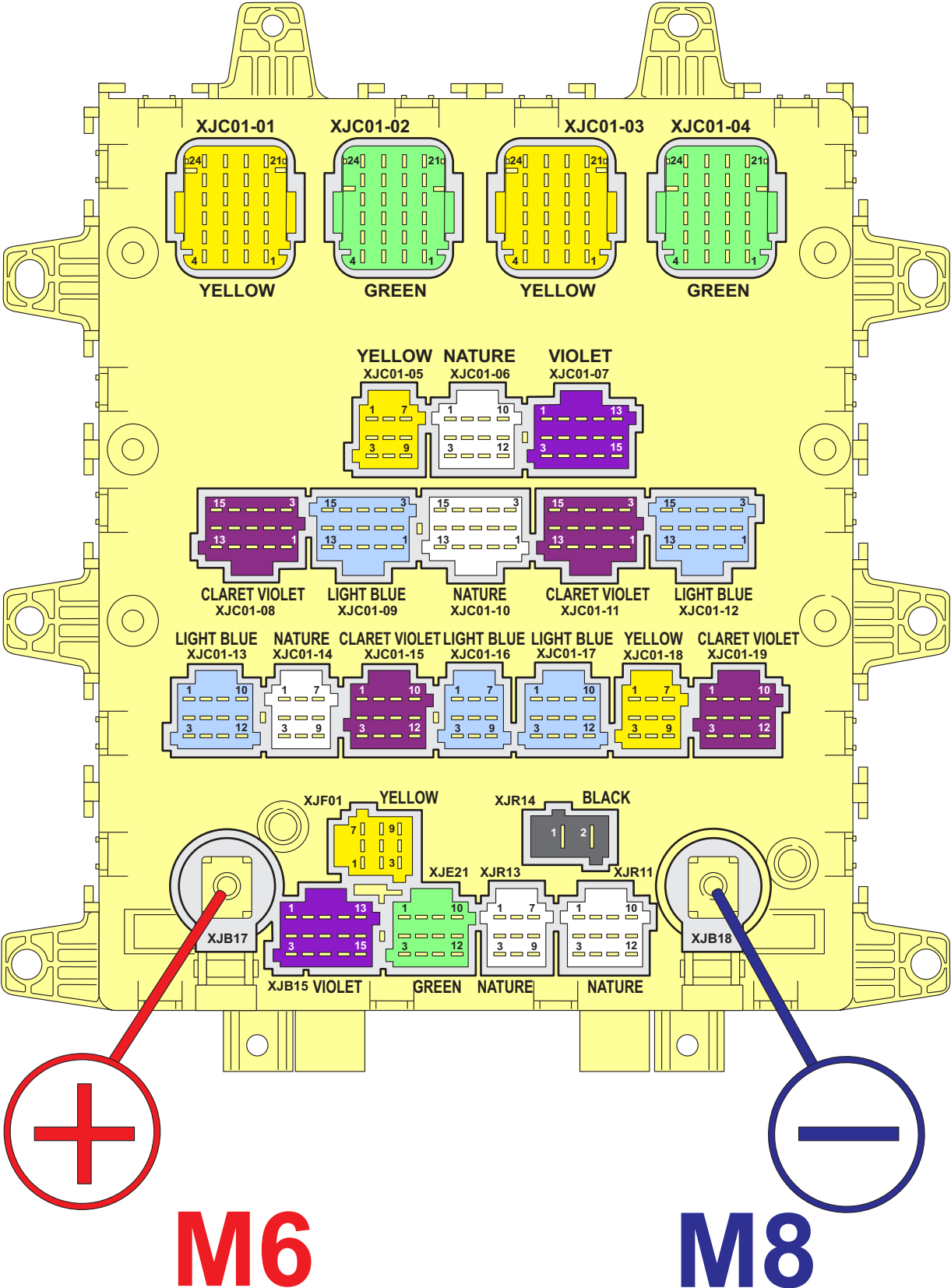

X77, Hybrid-box

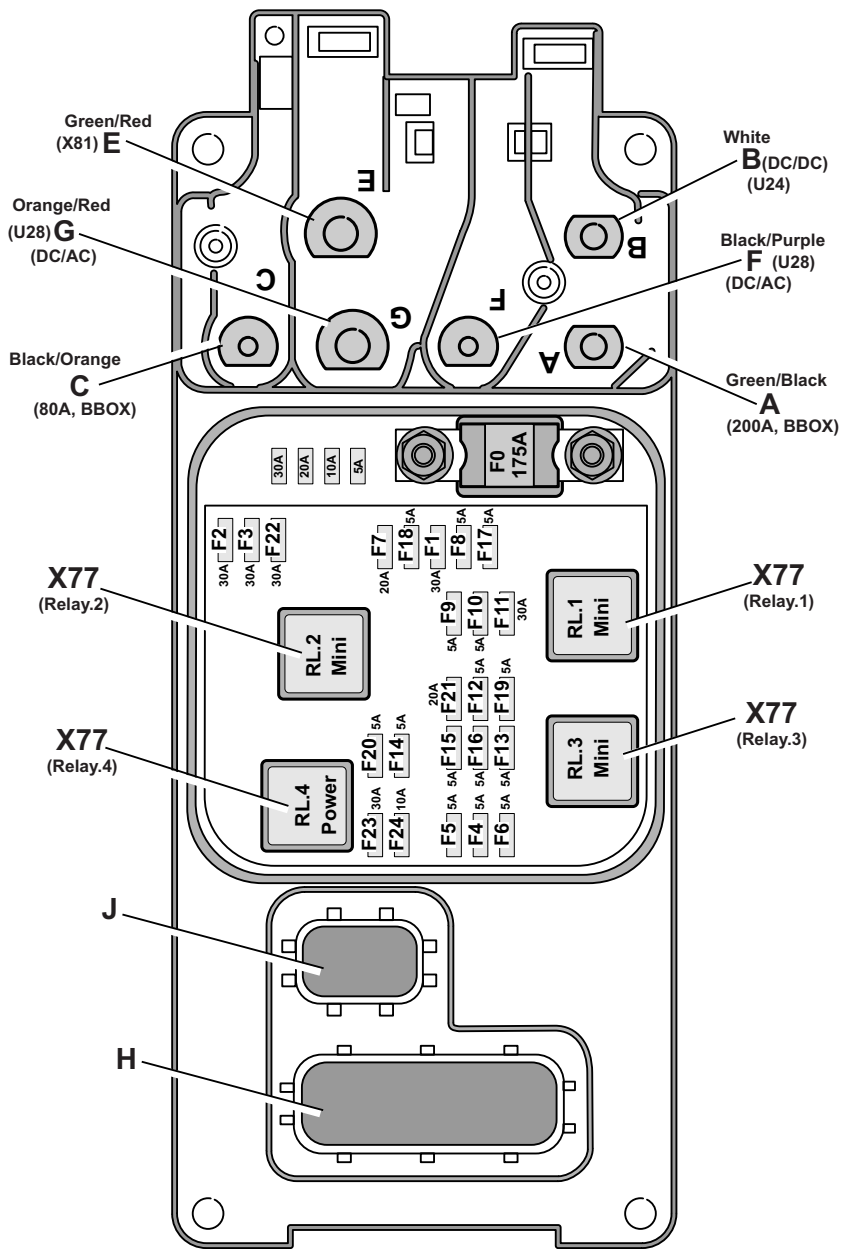

X77, Hybrid-box

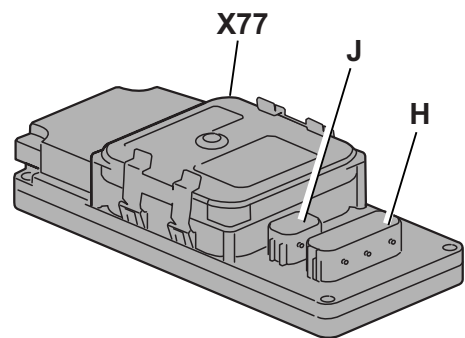
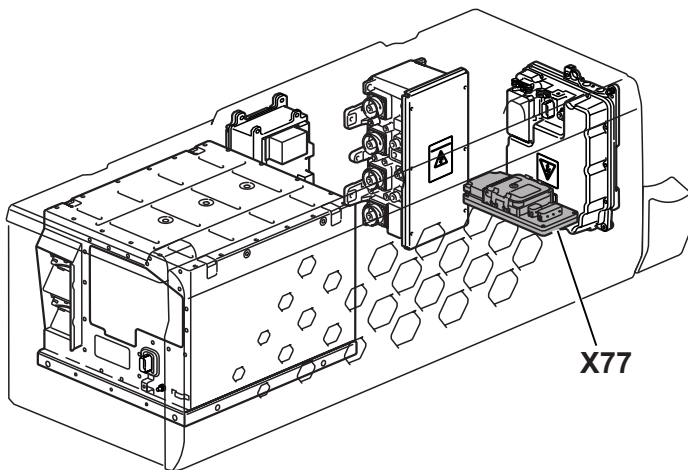

Junction box hybrid (X77)

Fuse	Ampere	Name	Connector
F1	30A	EPS cooling fan 1 supply	H19
F2	30A	EPS cooling fan 2 supply	H36
F3	30A	ESS cooling pump supply	H27
F4	5A	EPS cooling fan 1 HPCU ignition	H13
F5	5A	EPS cooling fan 2 HPCU ignition	H21
F6	5A	ESS cooling pump HPCU ignition	H23
F7	20A	HPCU power relay	–
F8	5A	ESS 24V power supply	H17
F9	5A	PEC powersupply	H31
F10	5A	600V DC/DC ECU power supply	H29
F11	30A	MDS cooling pump supply	H28
F12	5A	Auxiliary converter ignition	H34
F13	5A	HPCU ignition (DR signal)	H35
F14	5A	ESS ignition (DR signal)	H33
F15	5A	PEC ignition (DR signal)	H39
F16	5A	600/24V or 600/12 DC/DC (1) ignition	H38
F17	5A	Mini relay 3	–
F18	5A	Auxiliary converter DB (spare)	H30
F19	5A	MDS cooling pump HPCU ignition	H32
F20	5A	Spare fuse ignition	J8
F21	20A	Spare fuse after main switch	J9
F22	30A	Spare fuse DB	J13
F23	30A	Power relay 4	–
F24	10A	Free fuse	J12

SWITCH LHD

SWITCH LHD

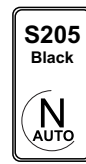
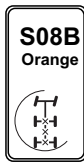
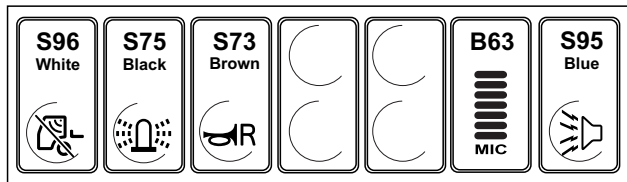

S146
Orange

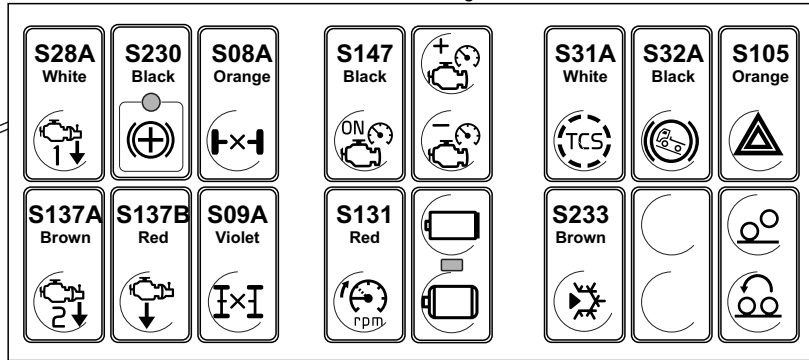

S229
Violet

S185
Violet

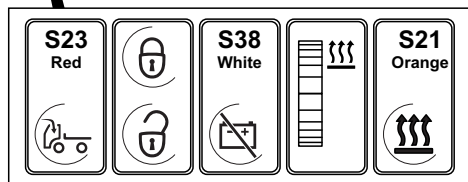
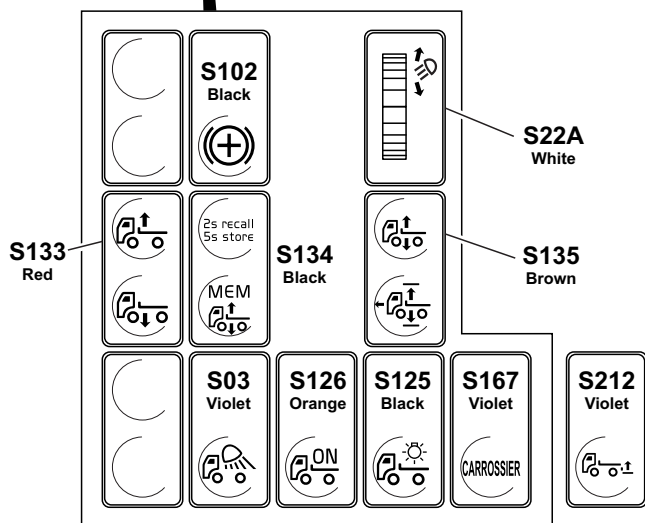
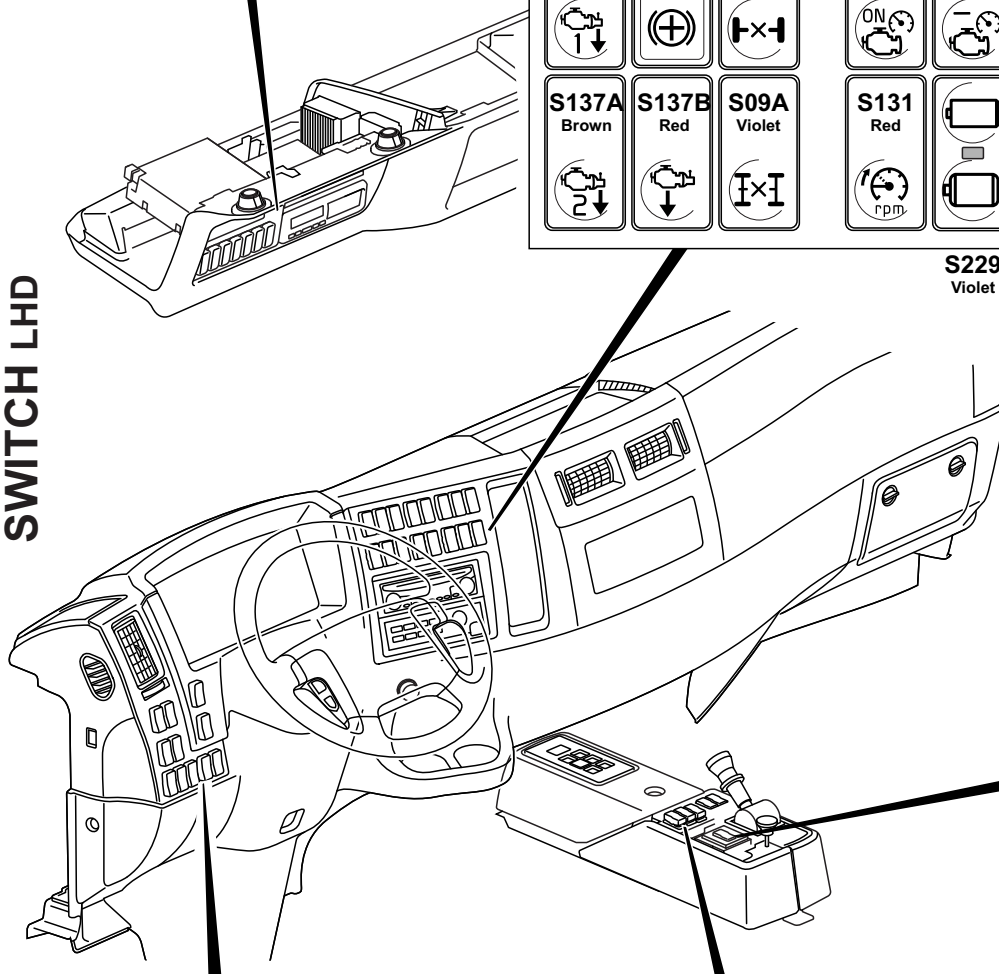

S115
Black

S151
Black

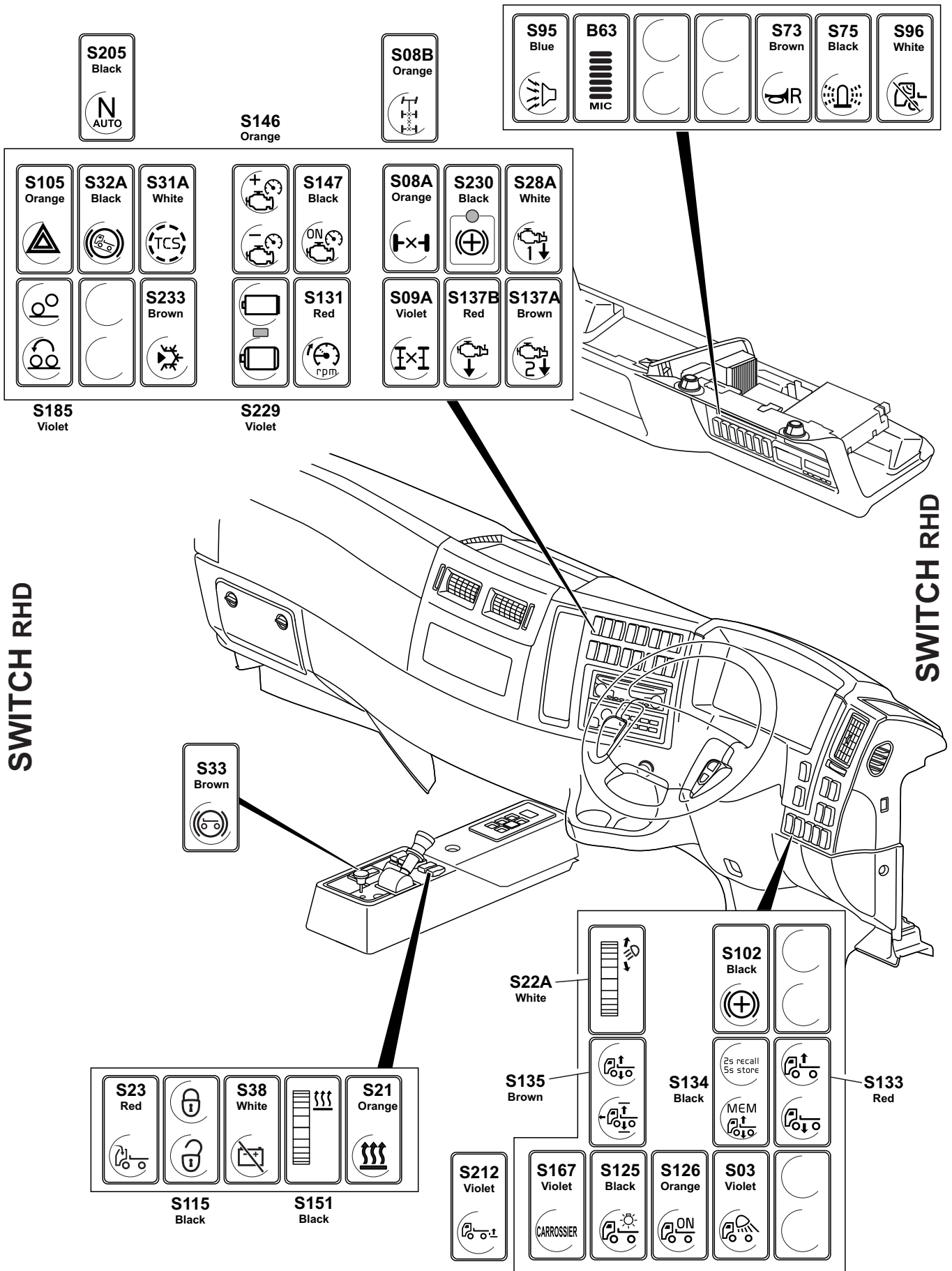

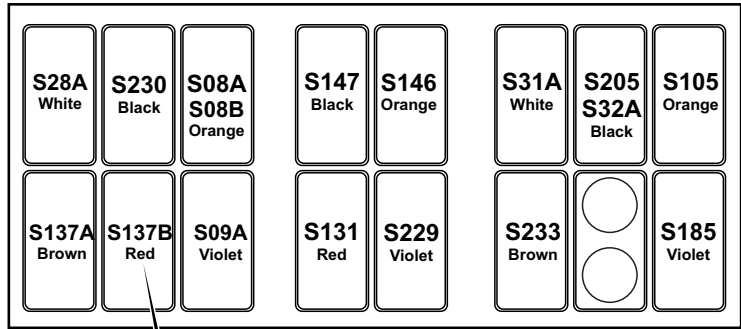
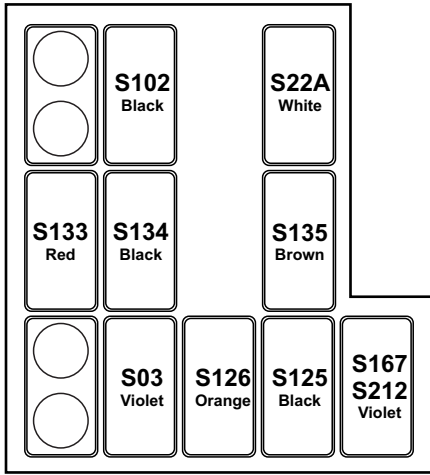
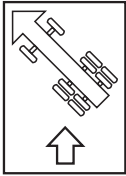

Only connector is supplied by Volvo

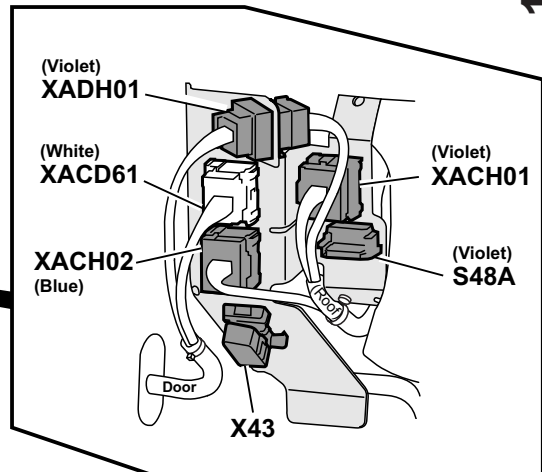
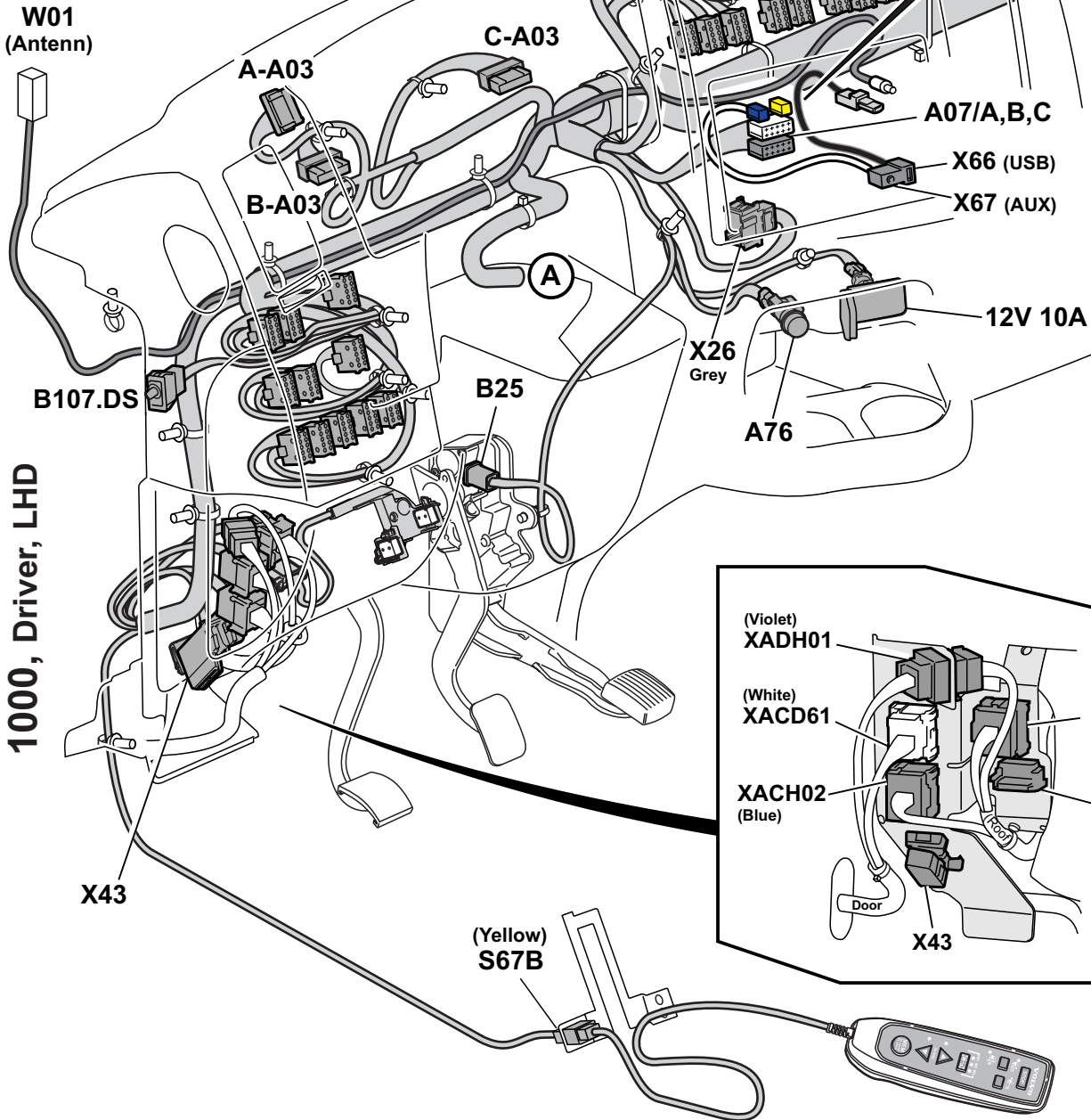
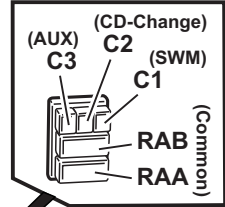

1000, Driver, LHD

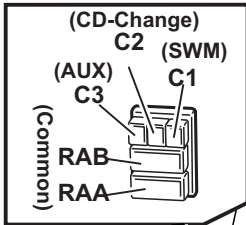
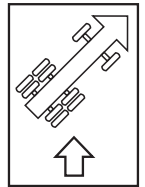
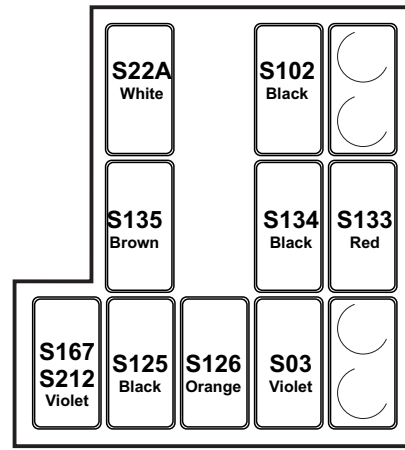
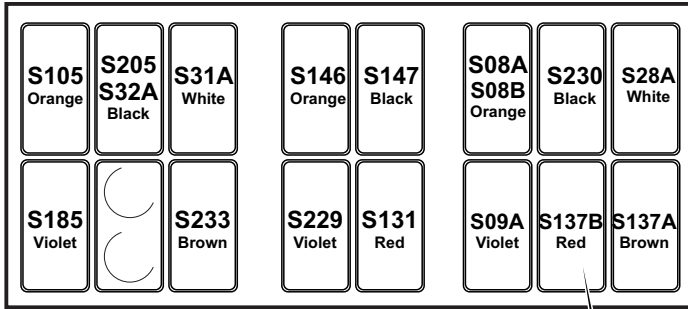

Only connector is supplied by Volvo

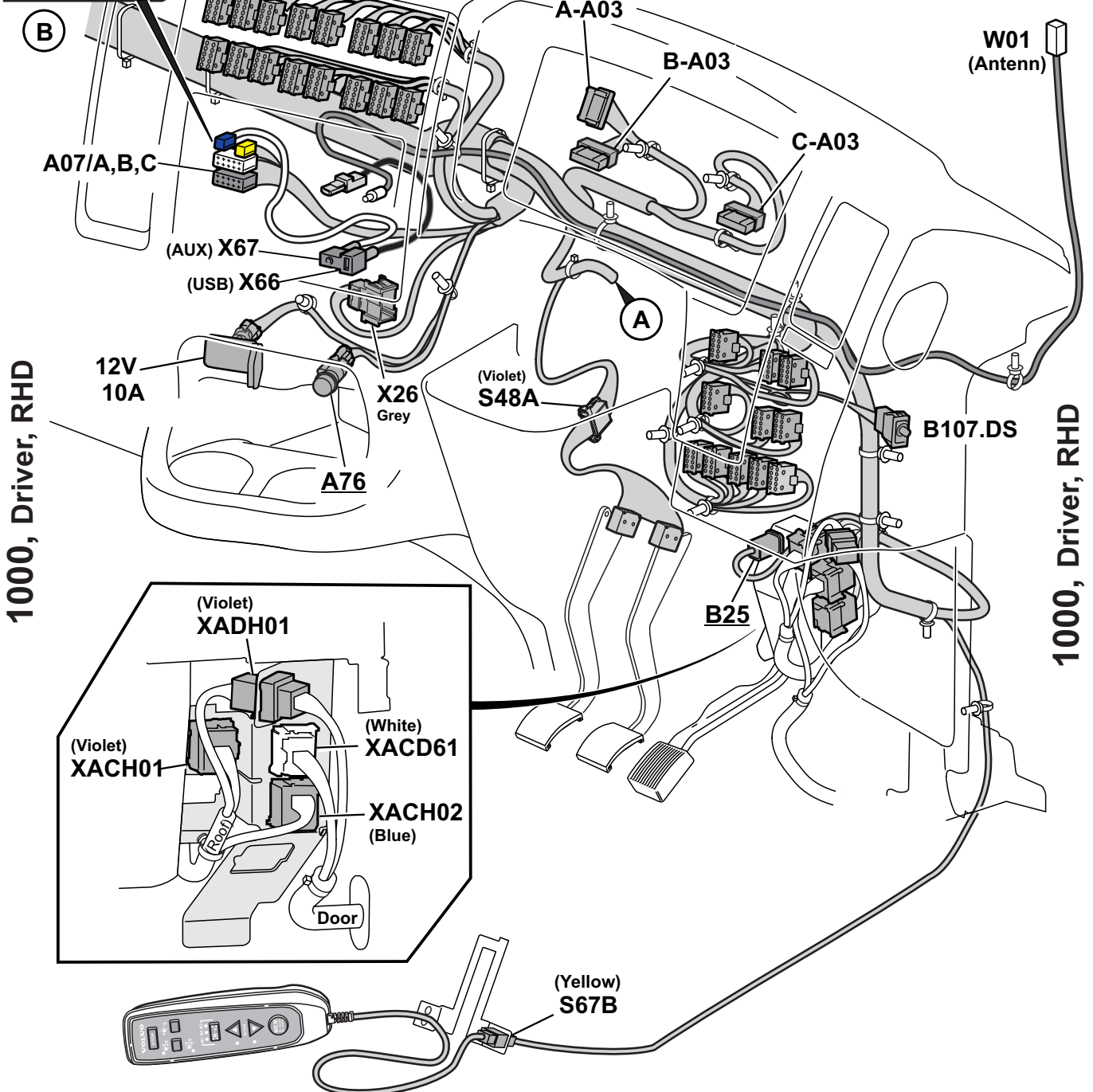

1000, Driver, RHD

1000, Driver, RHD

1000, Steering wheel

1000, Steering wheel

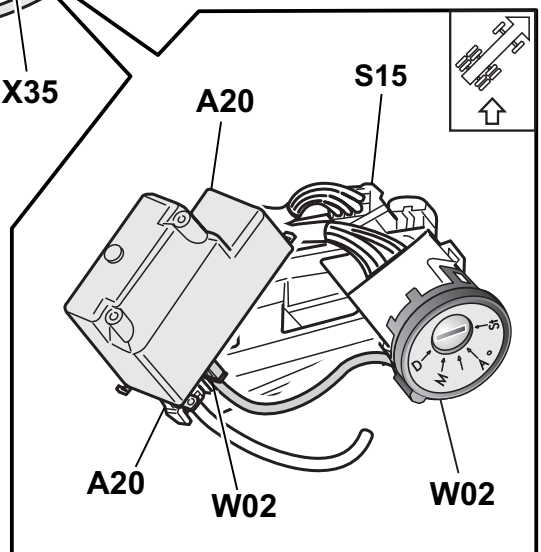
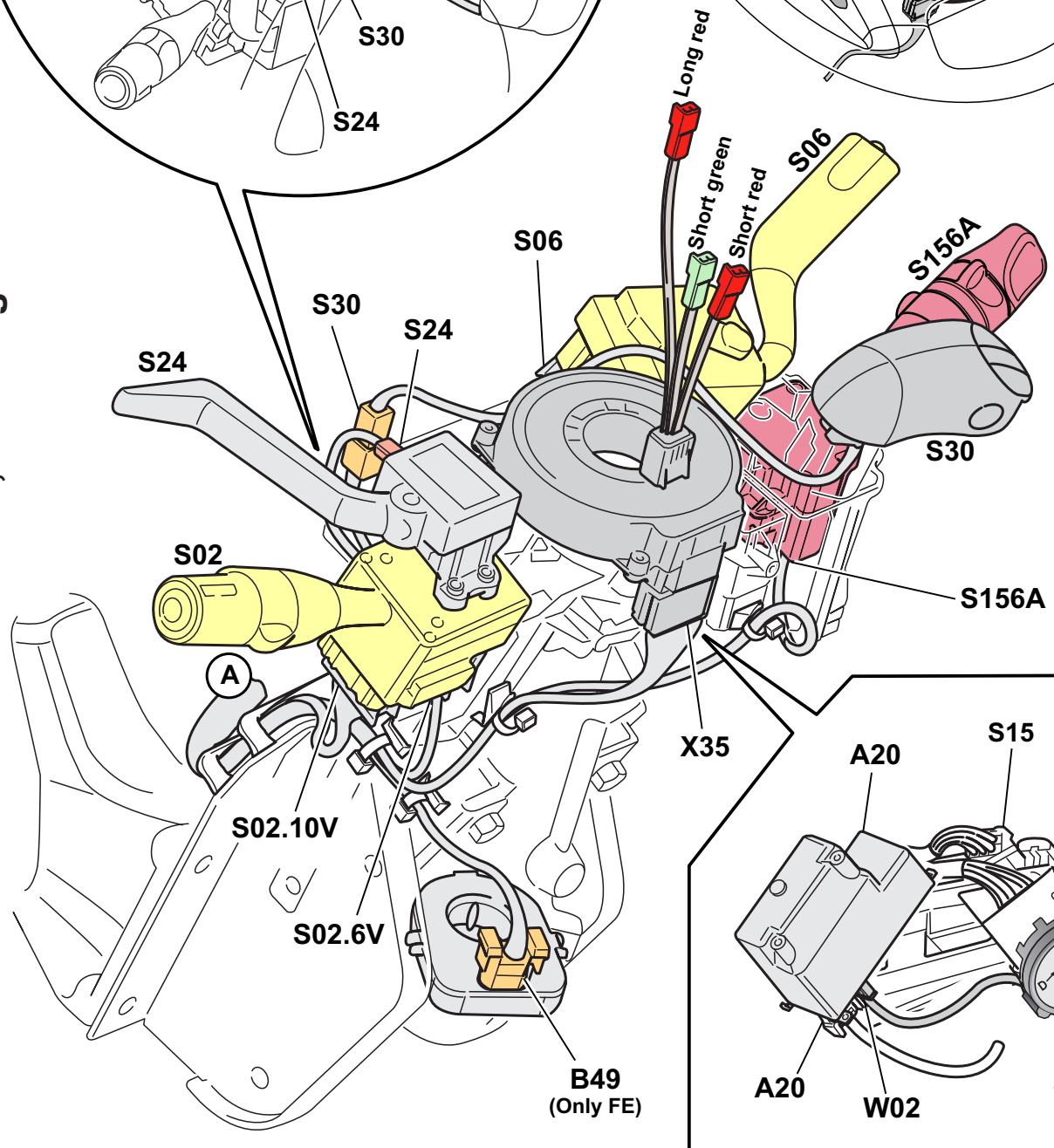
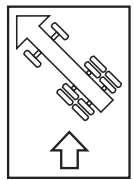
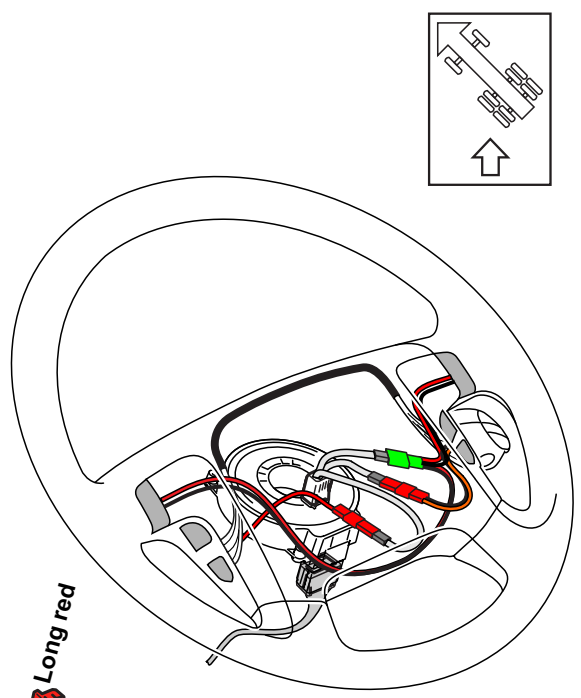
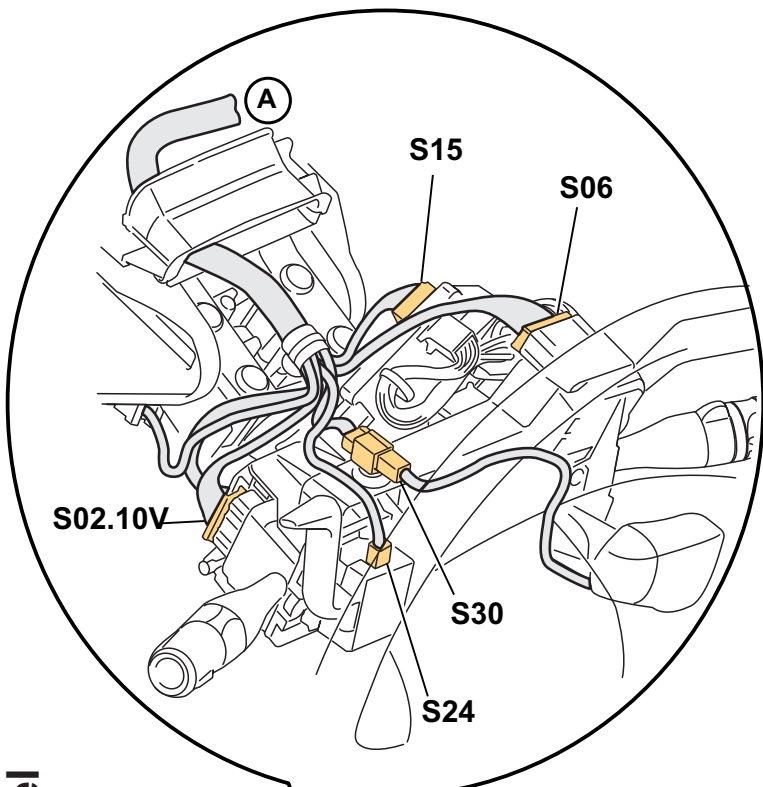

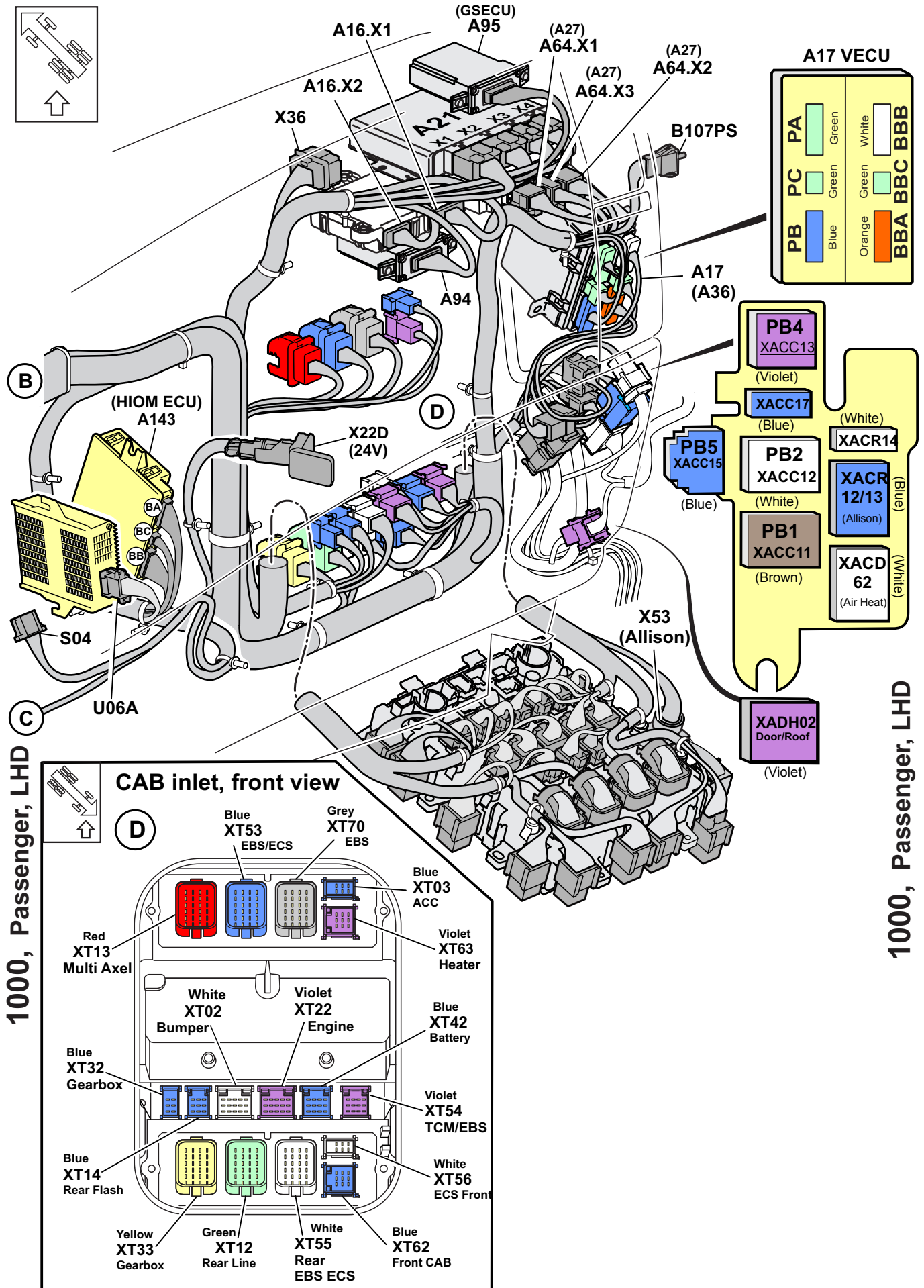

1000, Passenger, RHD

1000, Passenger, RHD

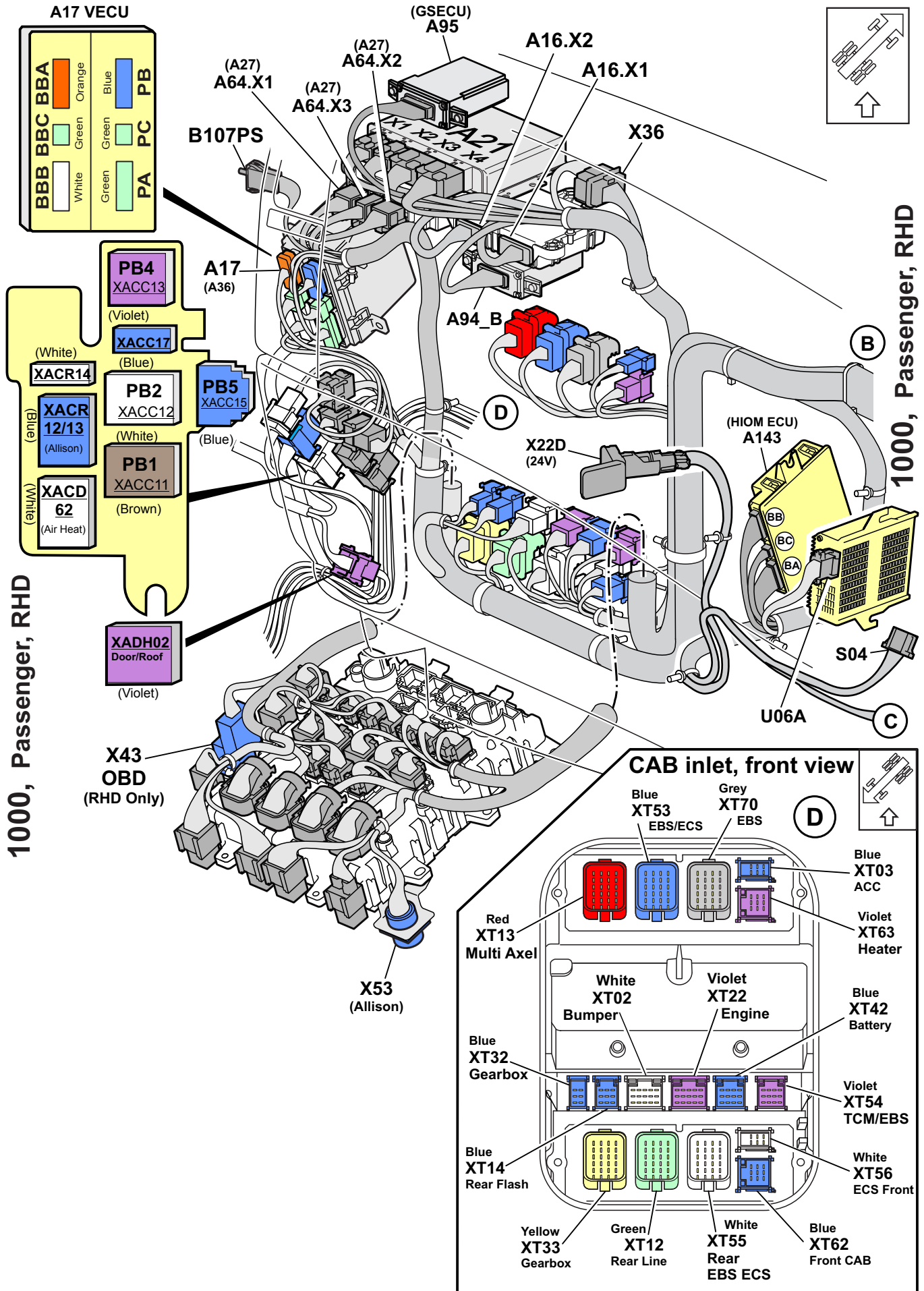

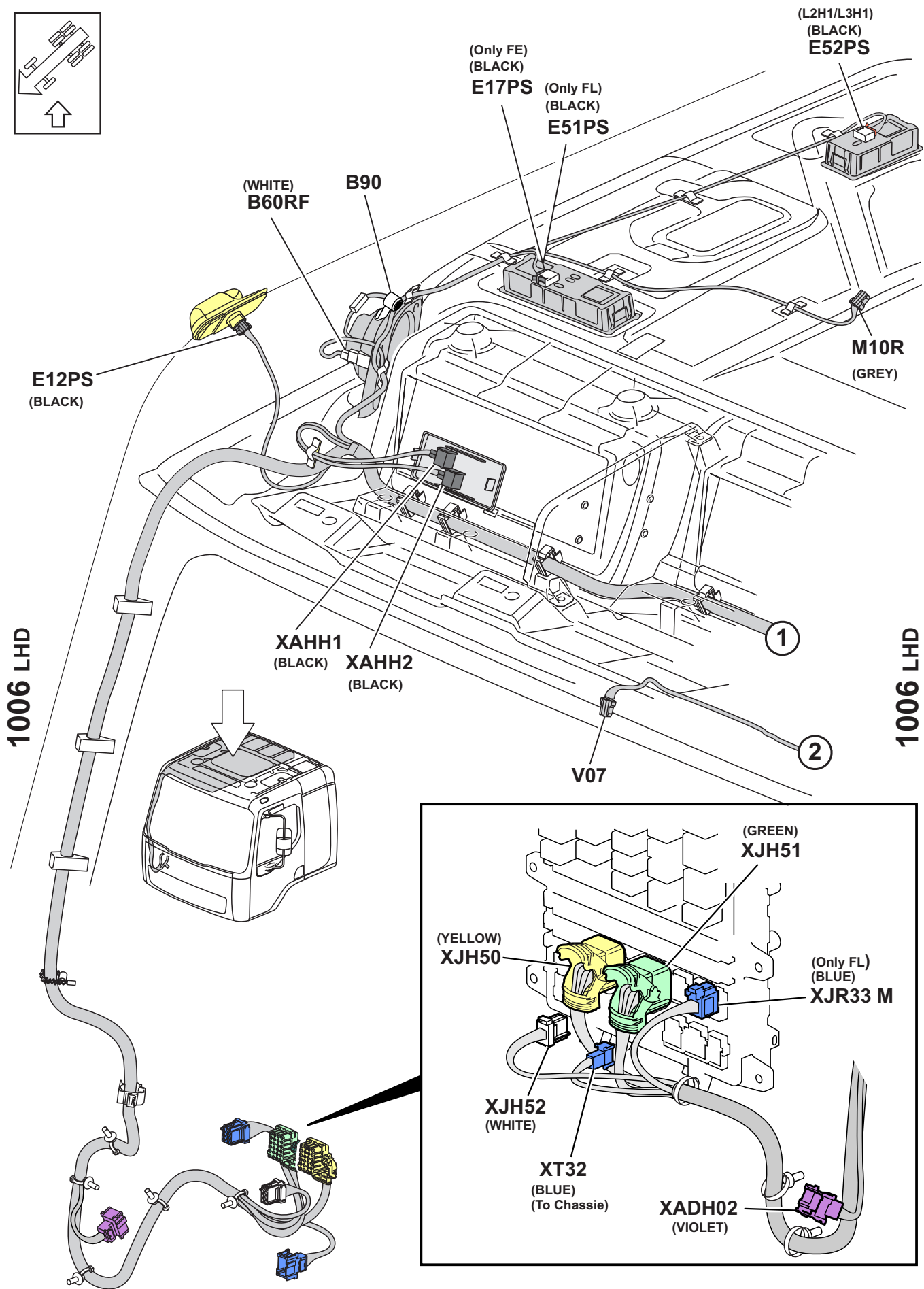
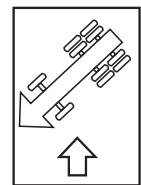

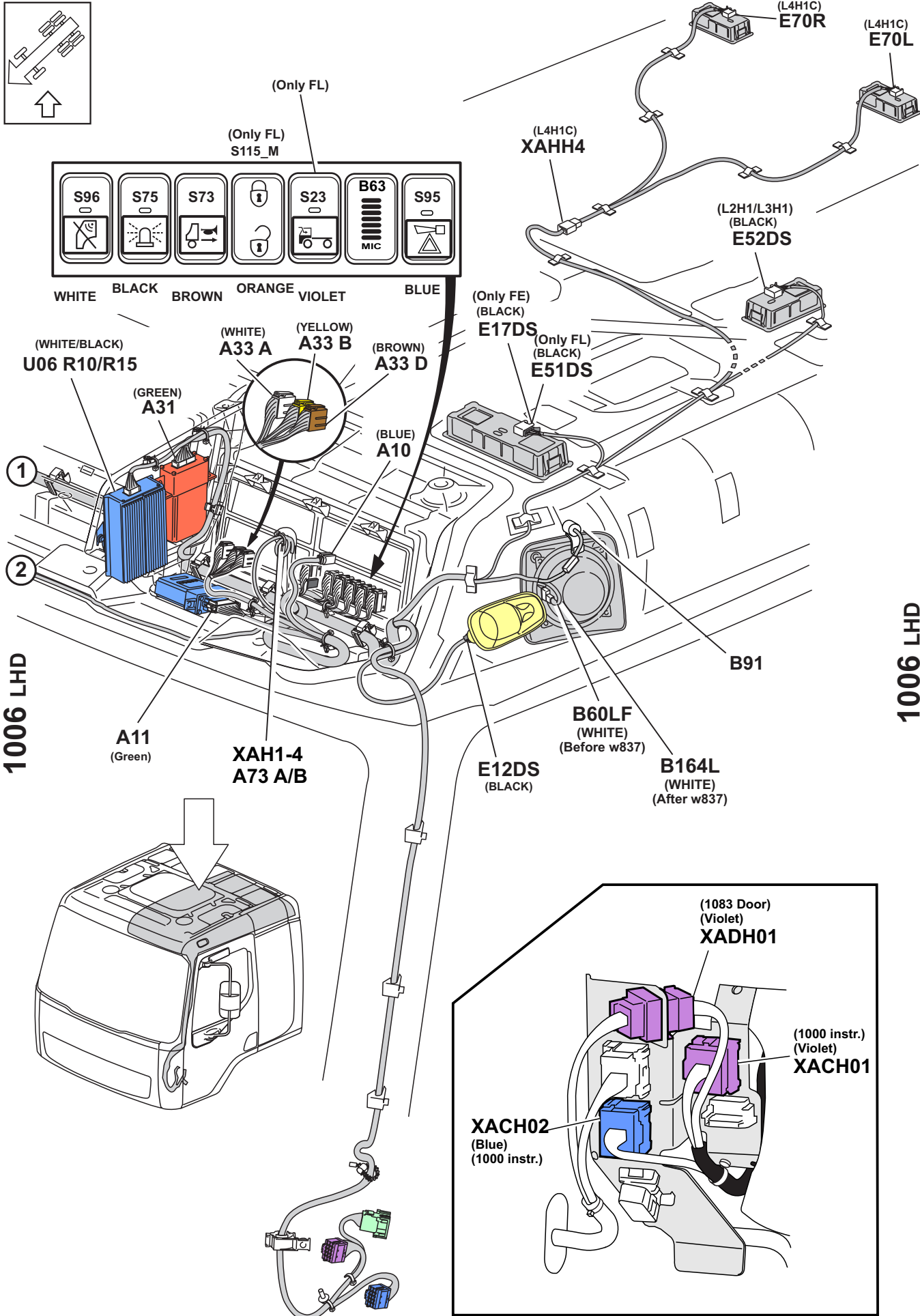
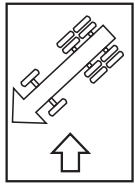

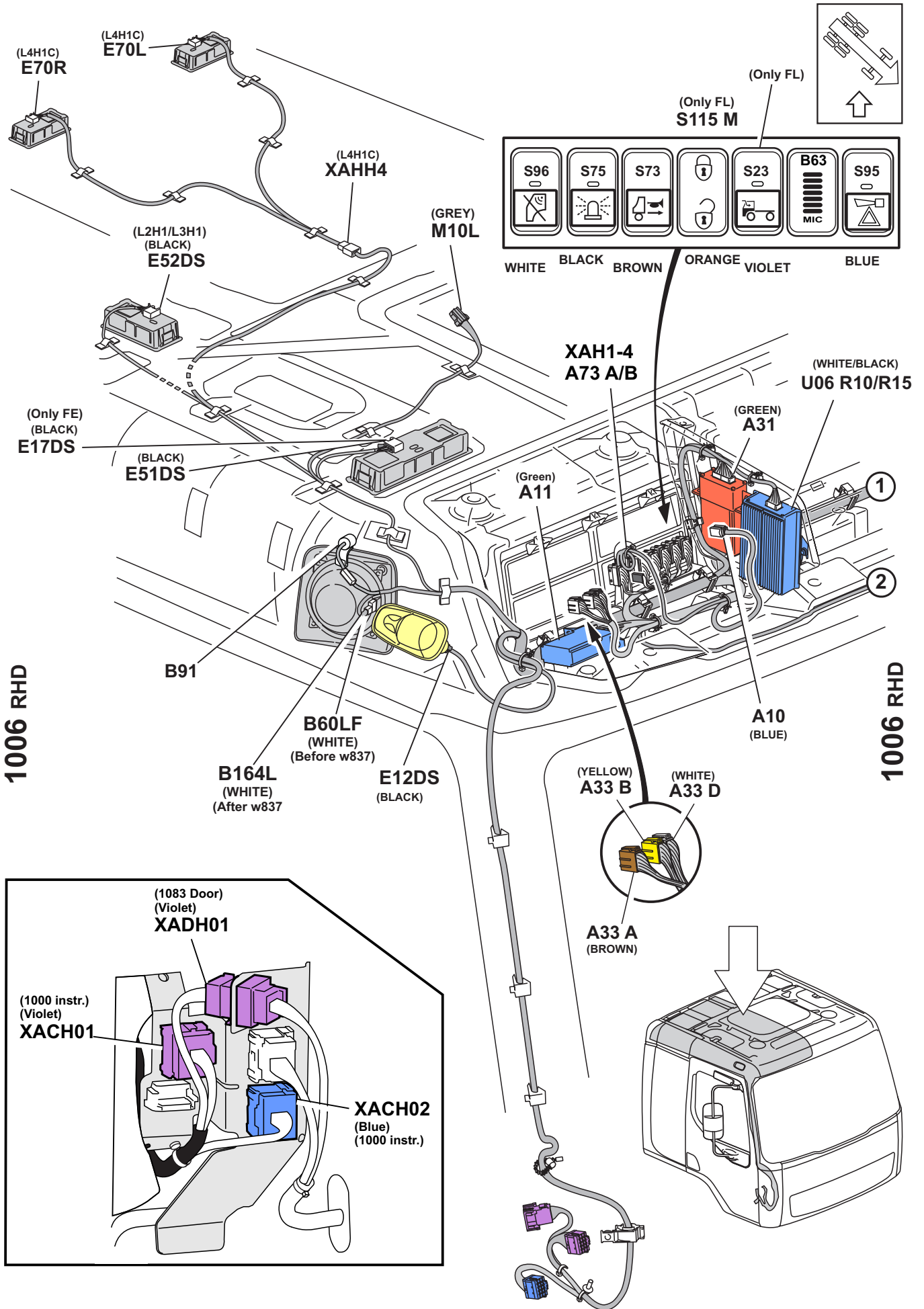

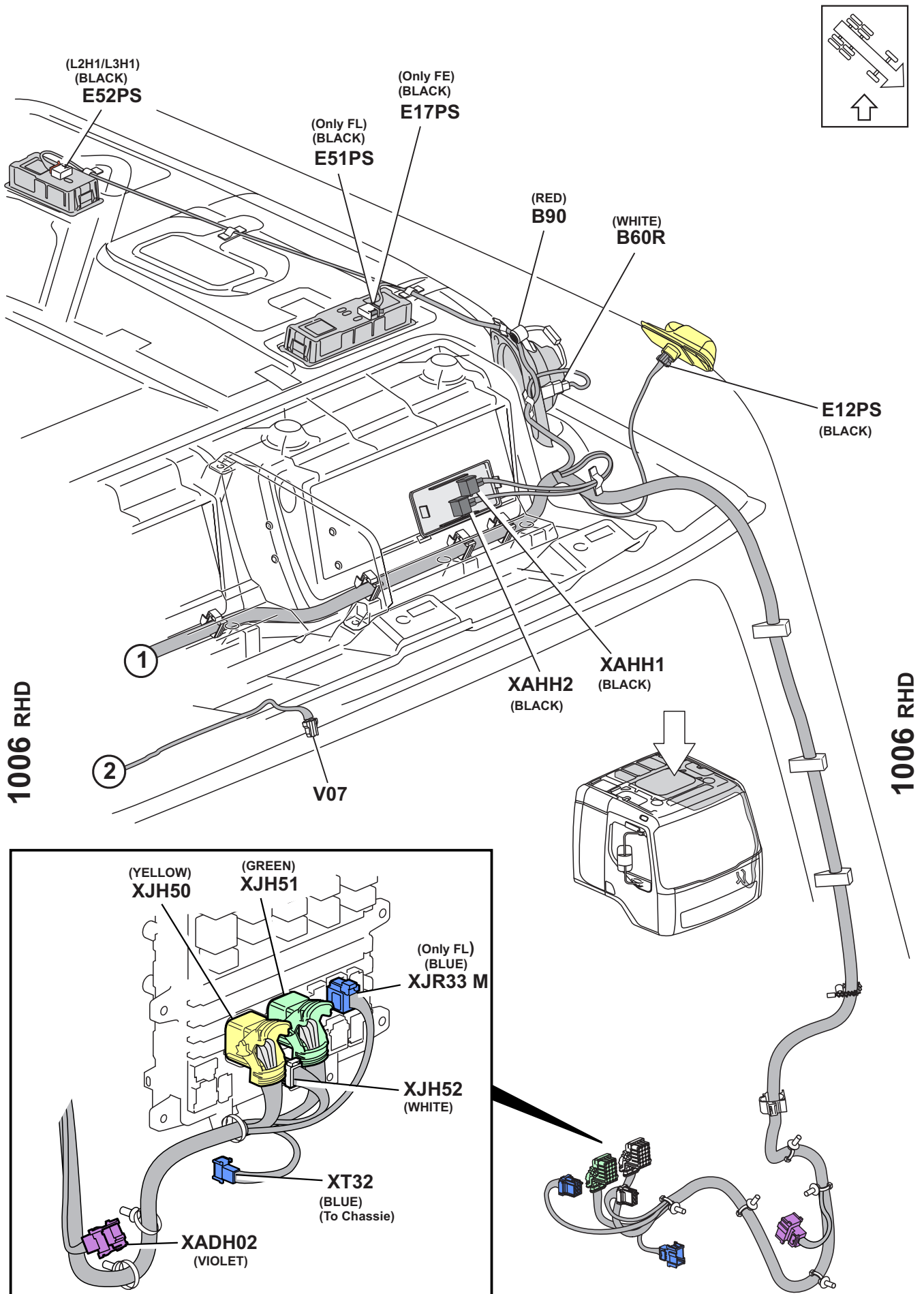

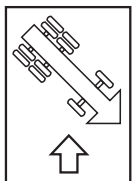
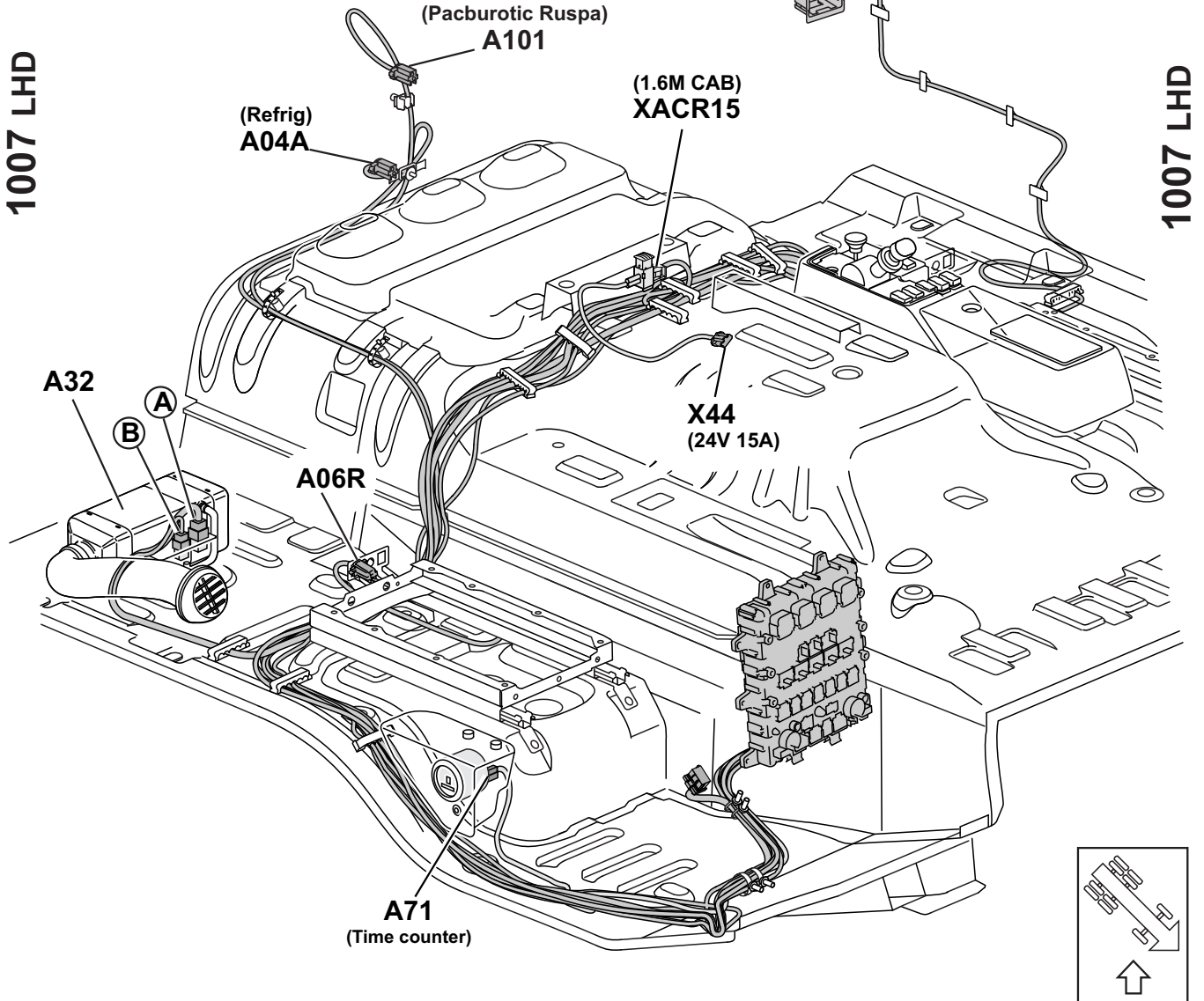
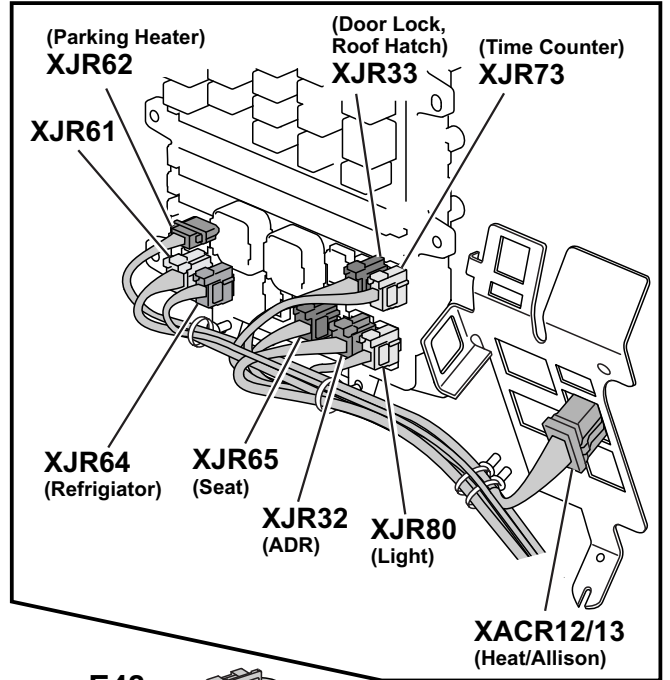
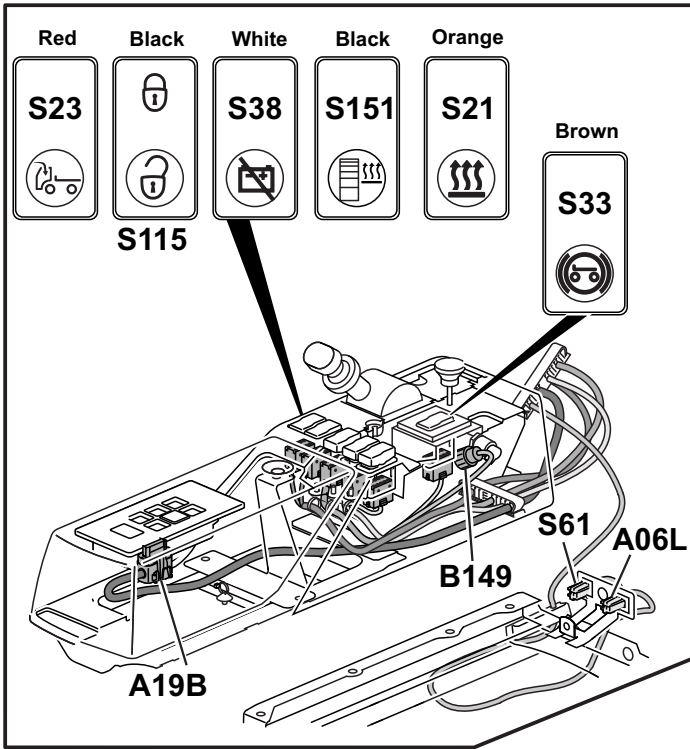

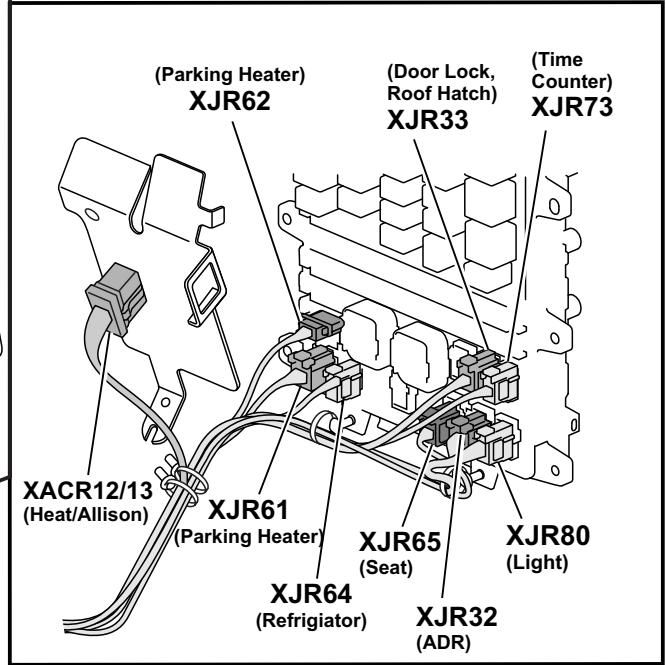
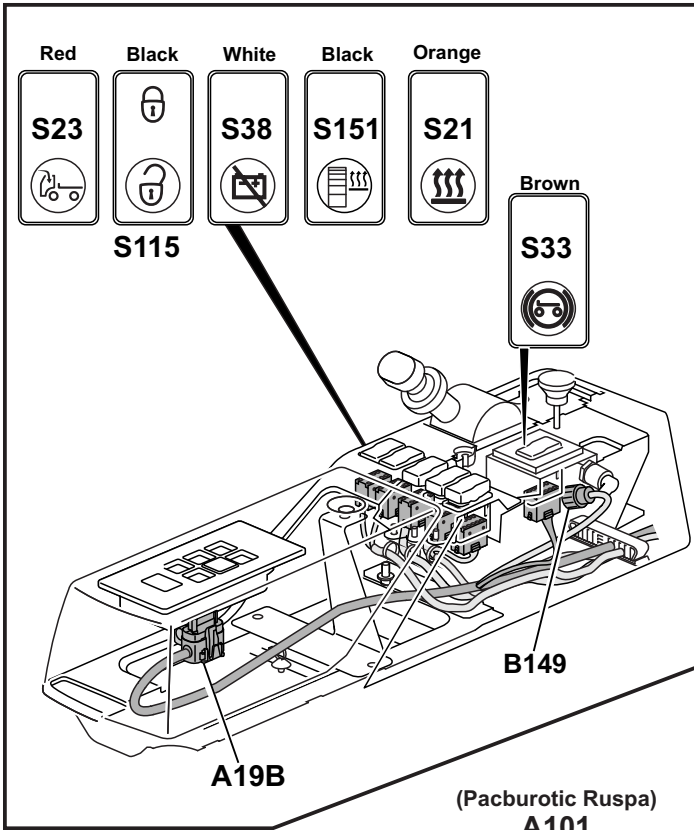

1007 RHD

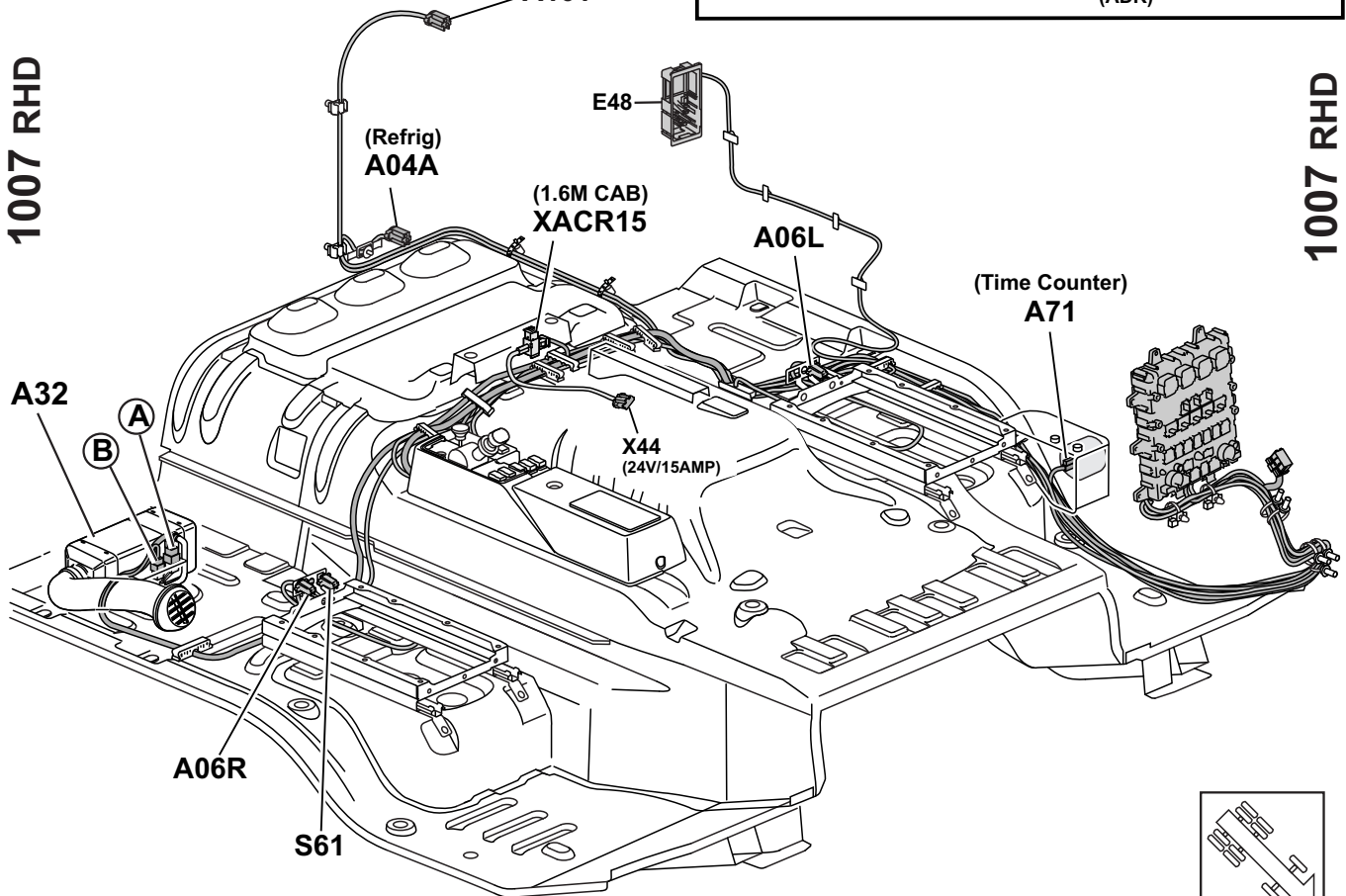

1007 RHD

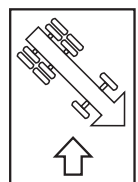

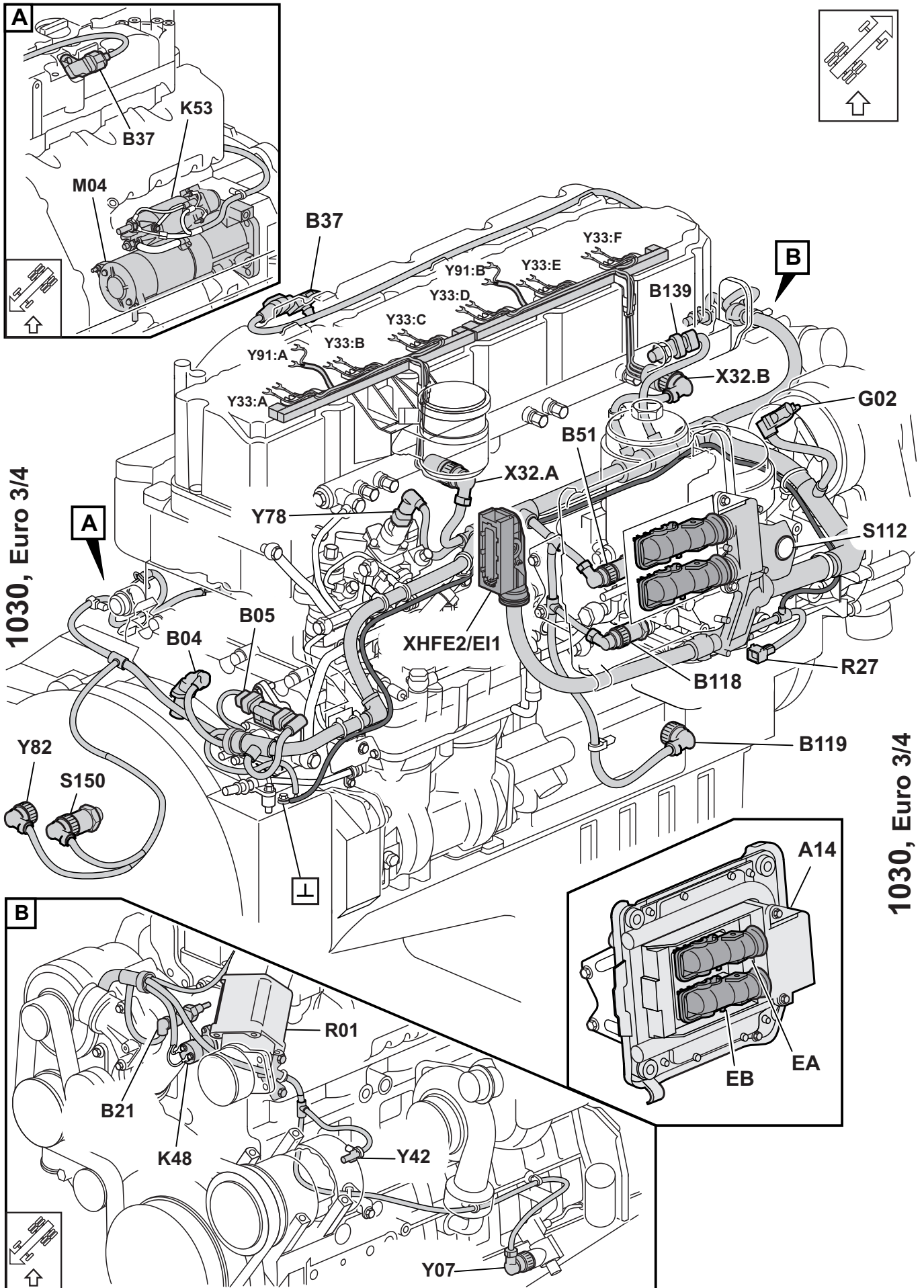

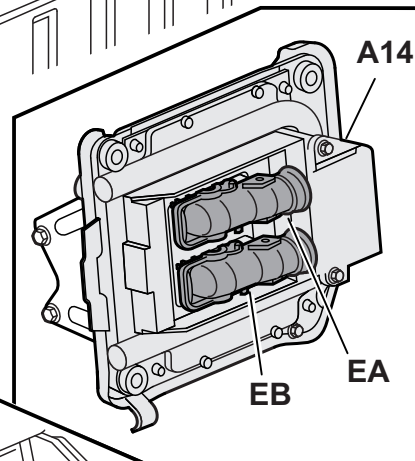
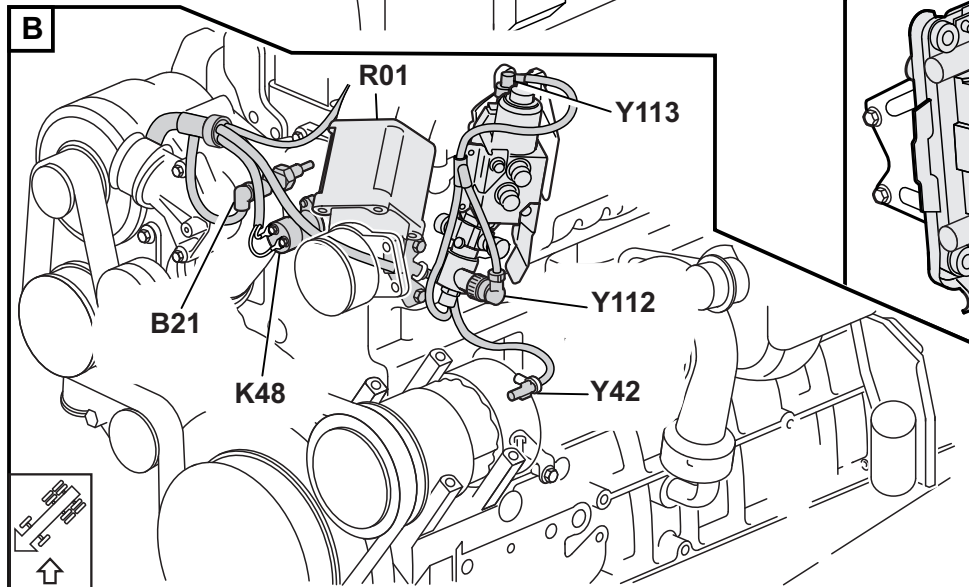
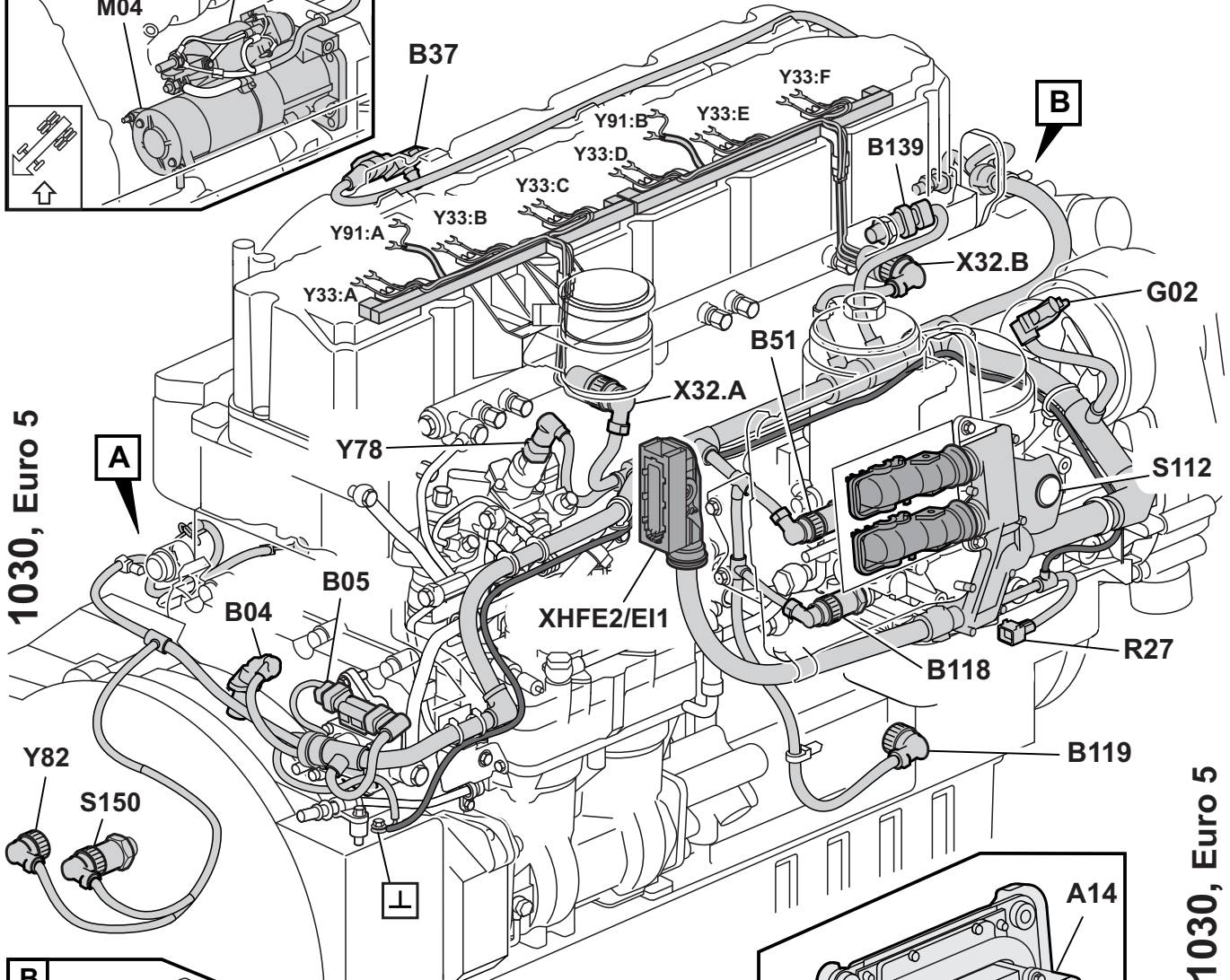
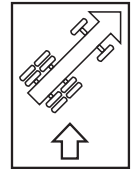
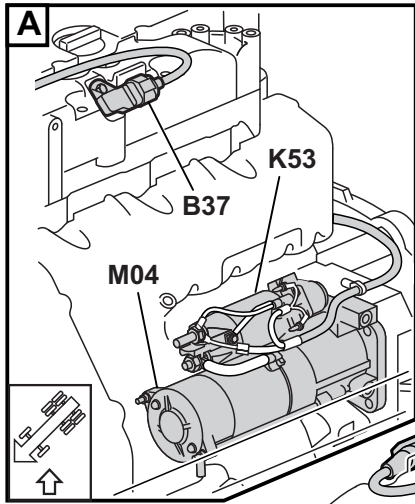

1030, Euro 5

1030, Euro 5

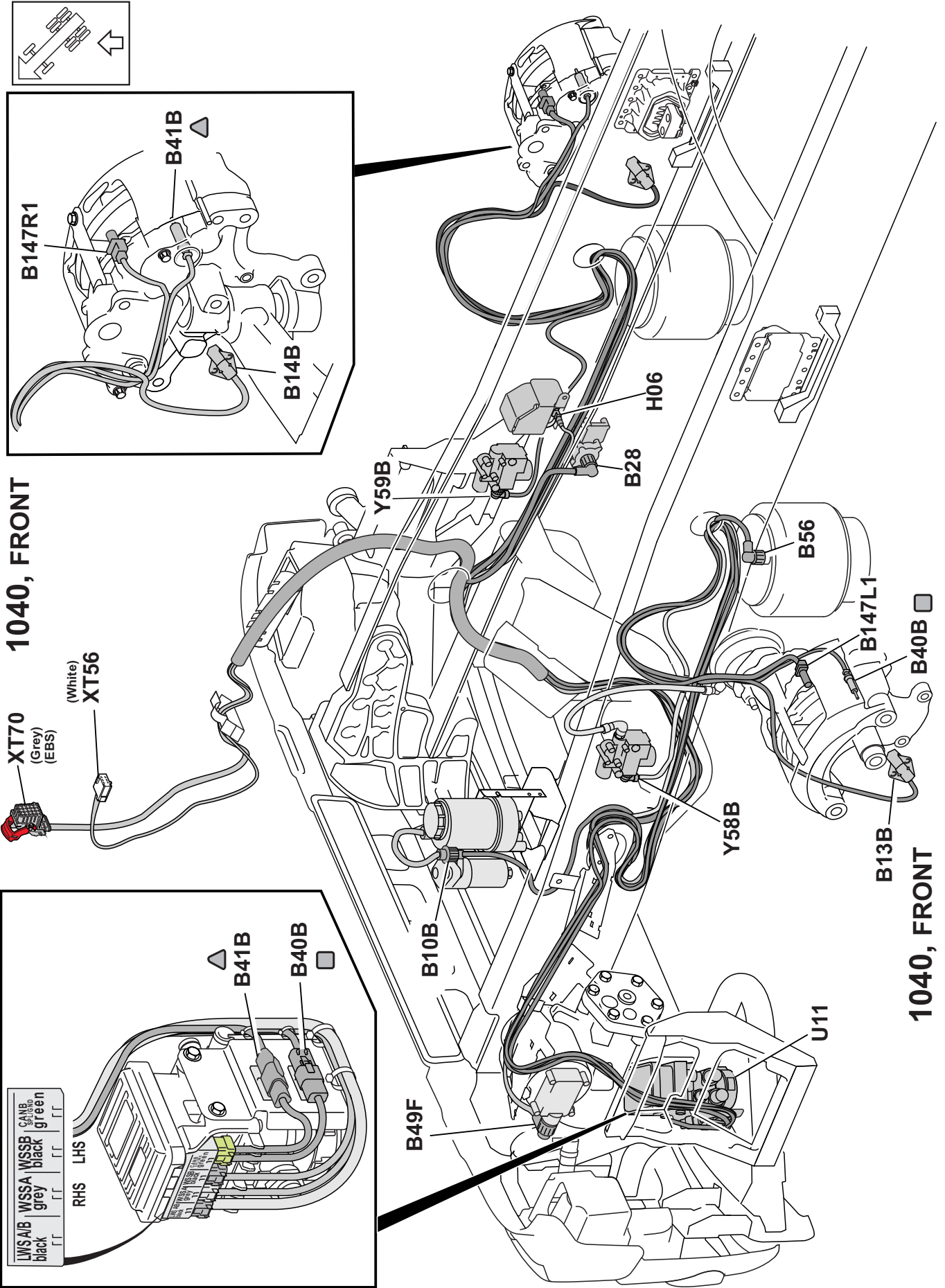

1040, Rear, Rigid

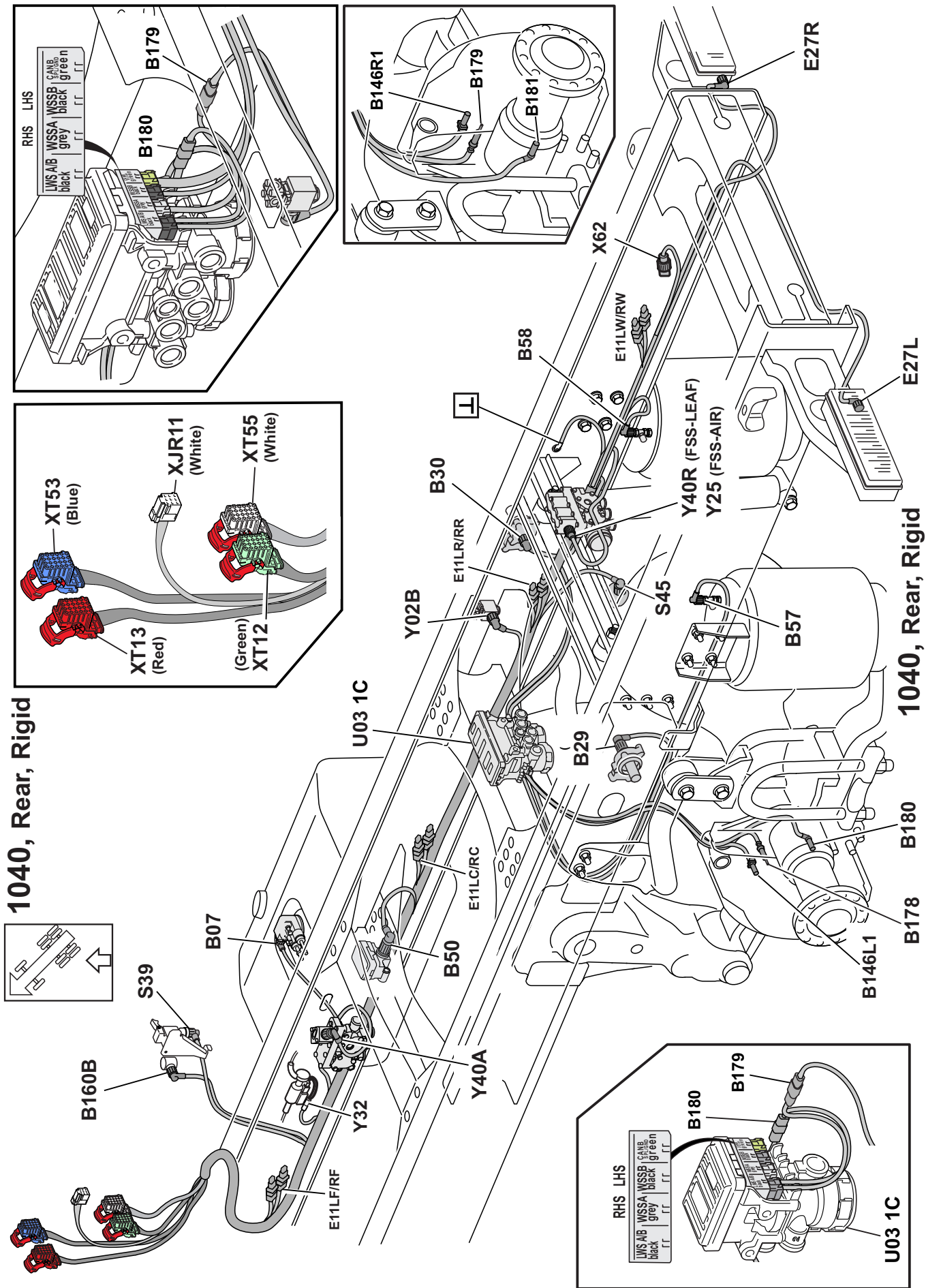

1040, Rear, Rigid

1040, Rear, Tractor

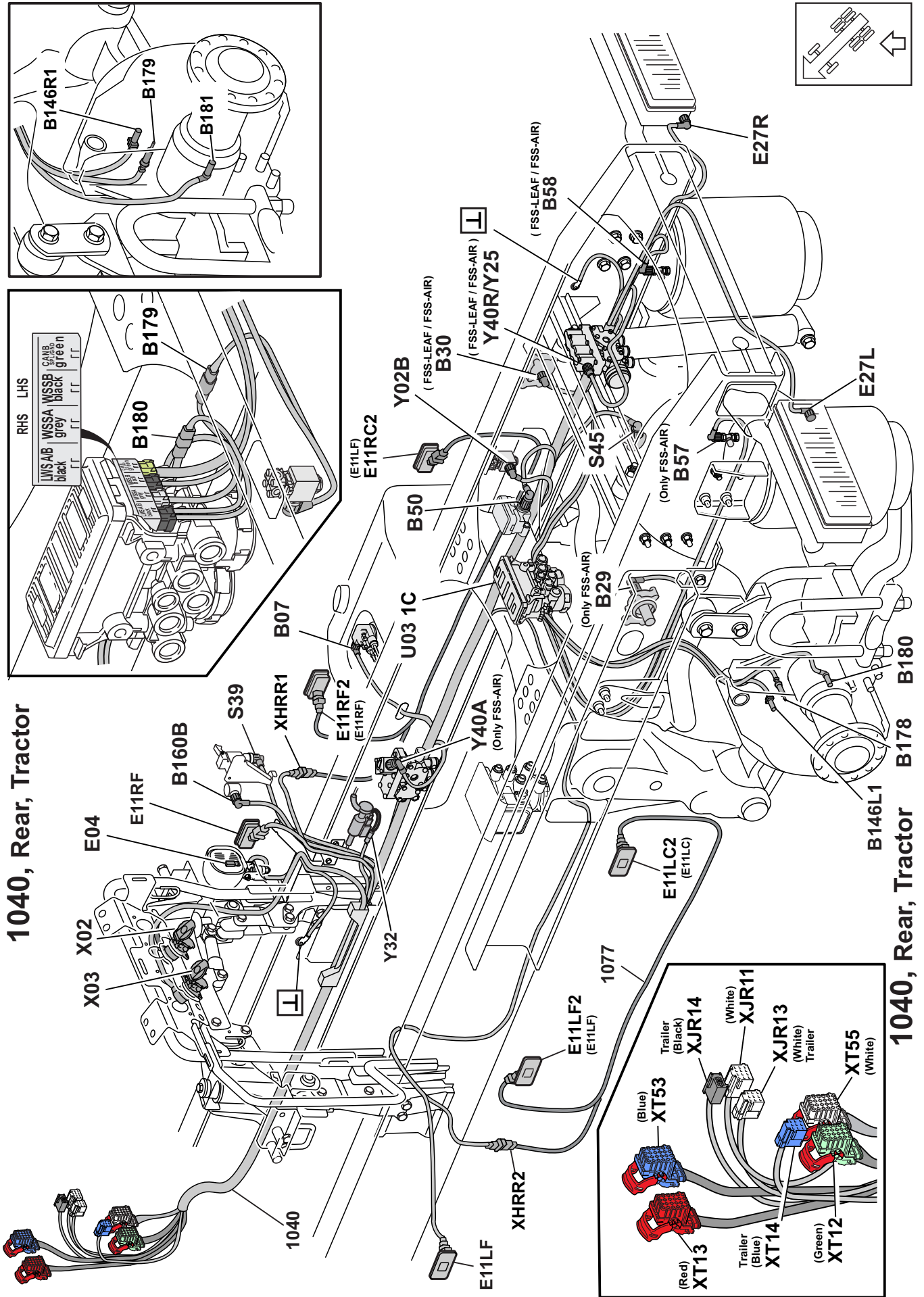

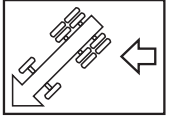
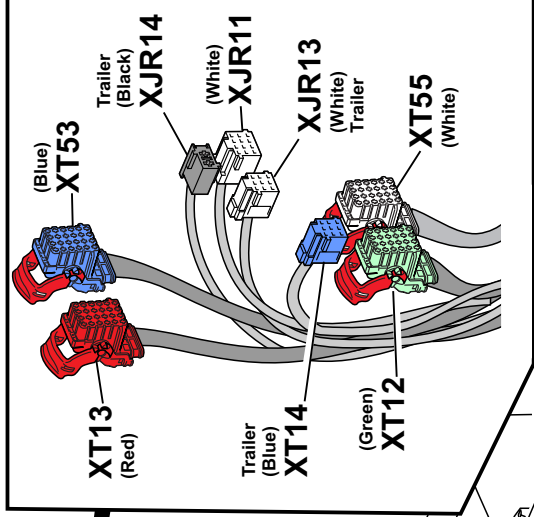
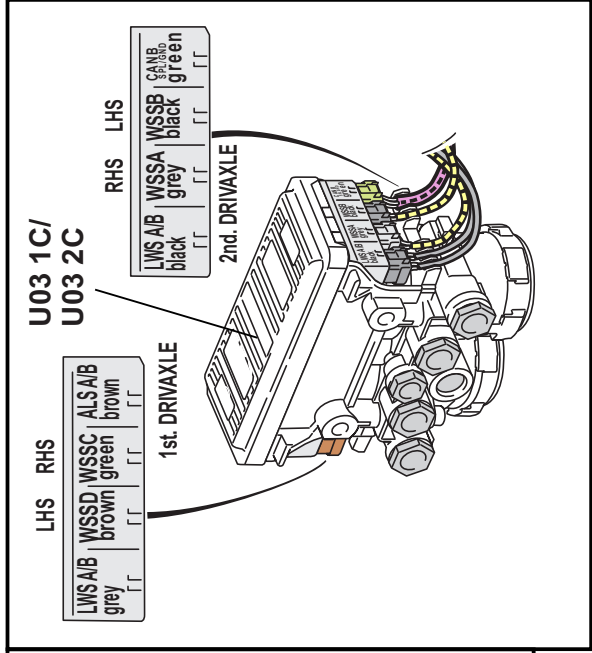
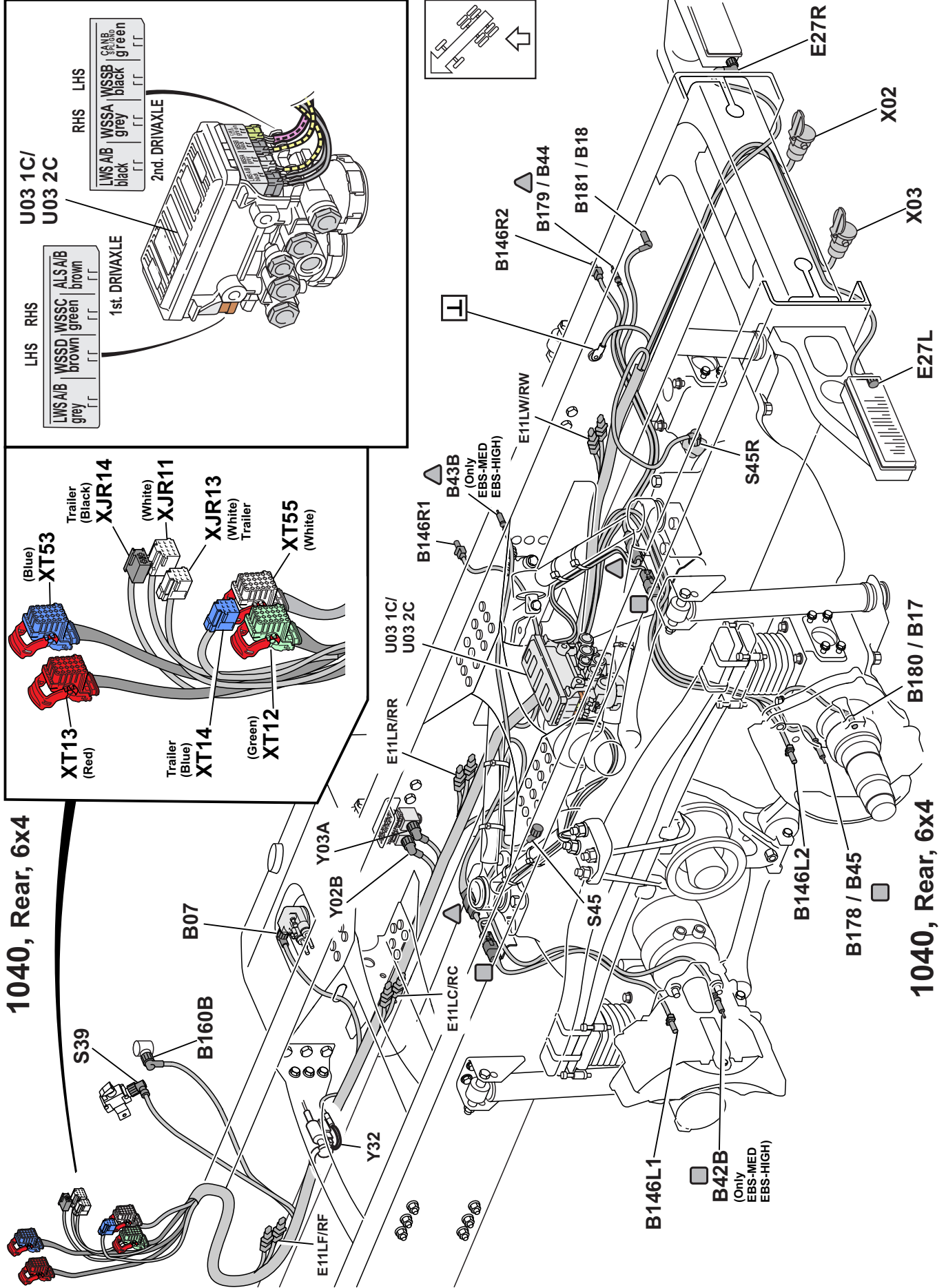

1040, 1057, EM-EC01

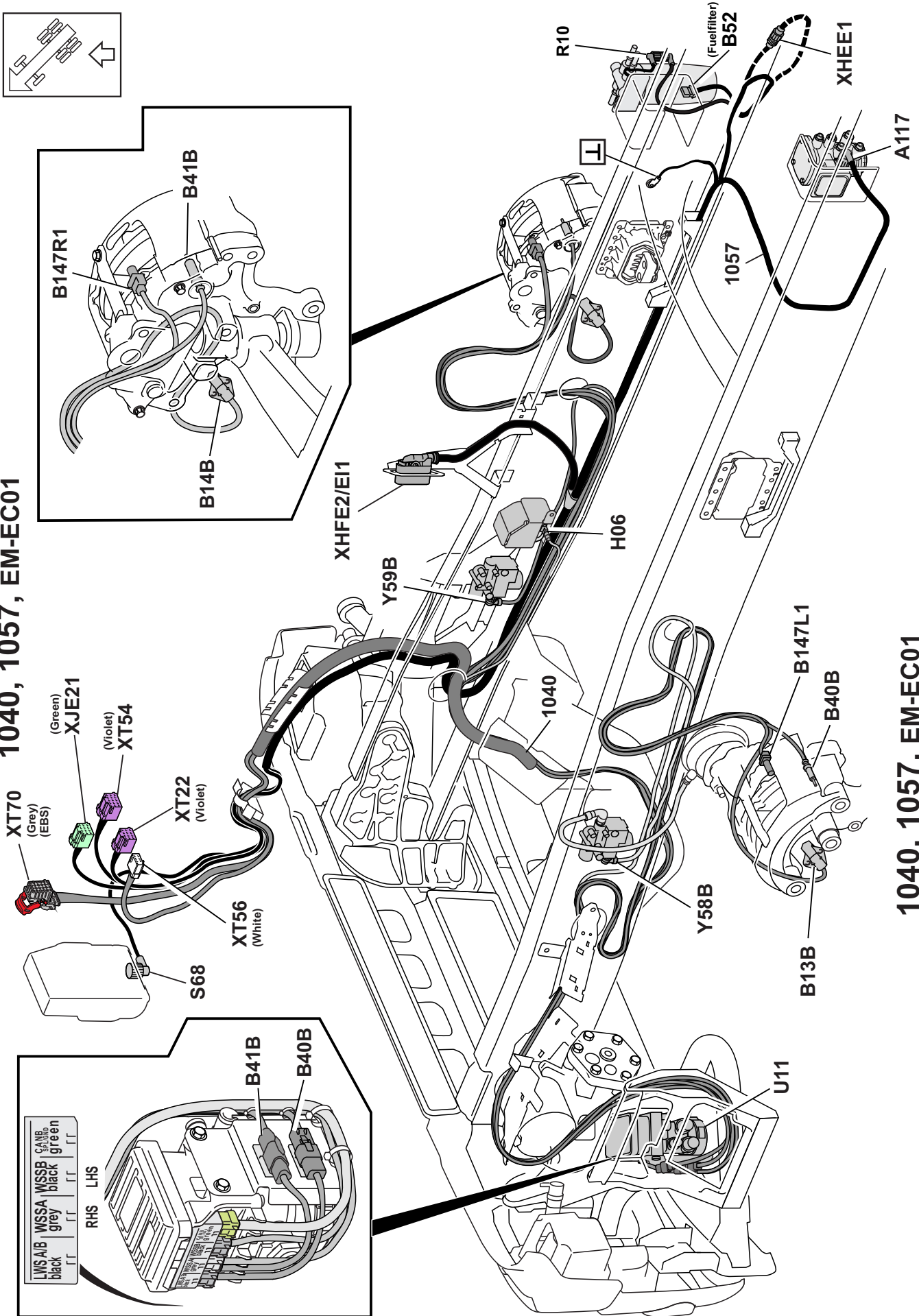

1040, 1057, EM-EC01

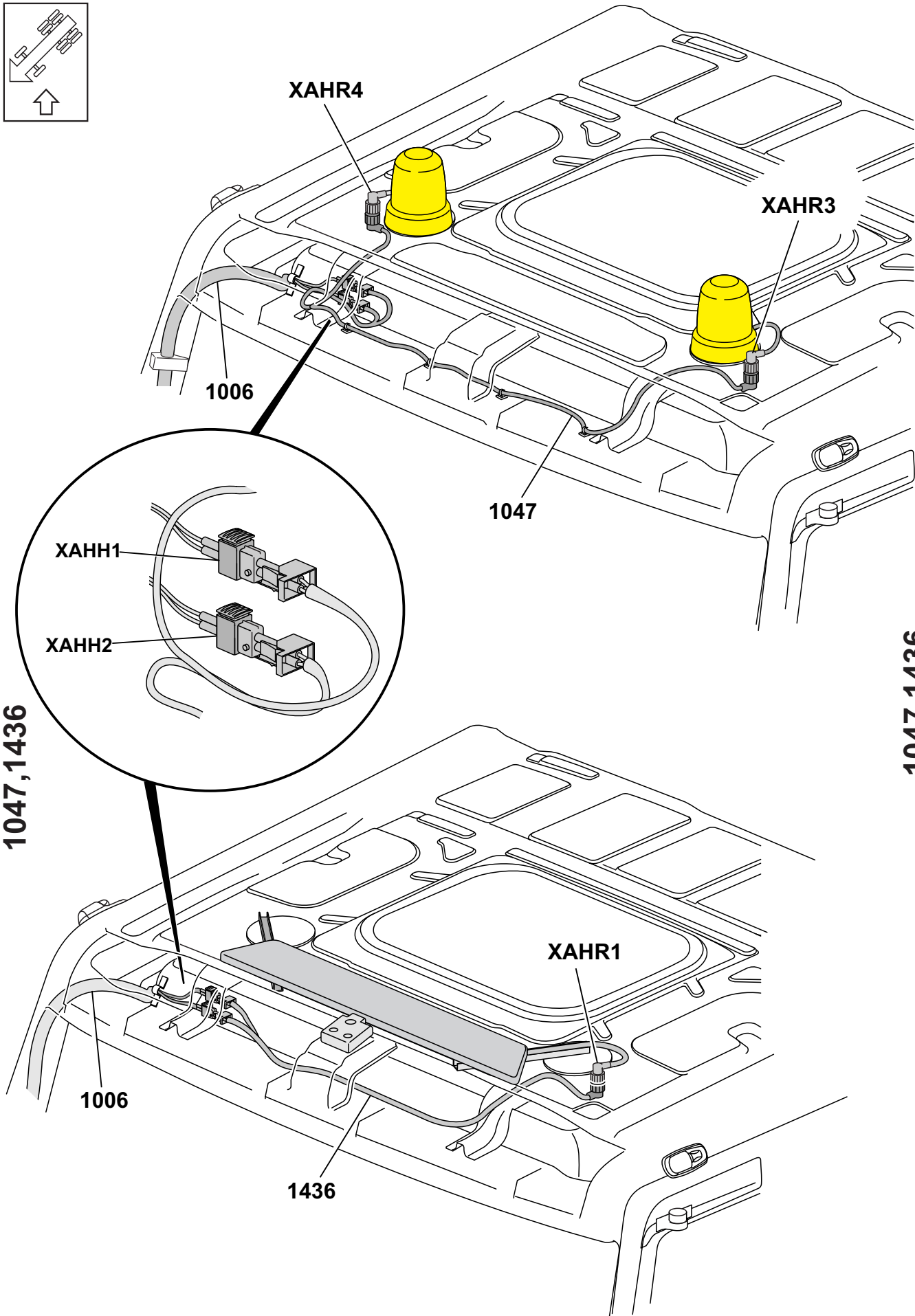
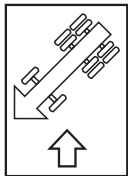

1047, 1436

1047, 1436

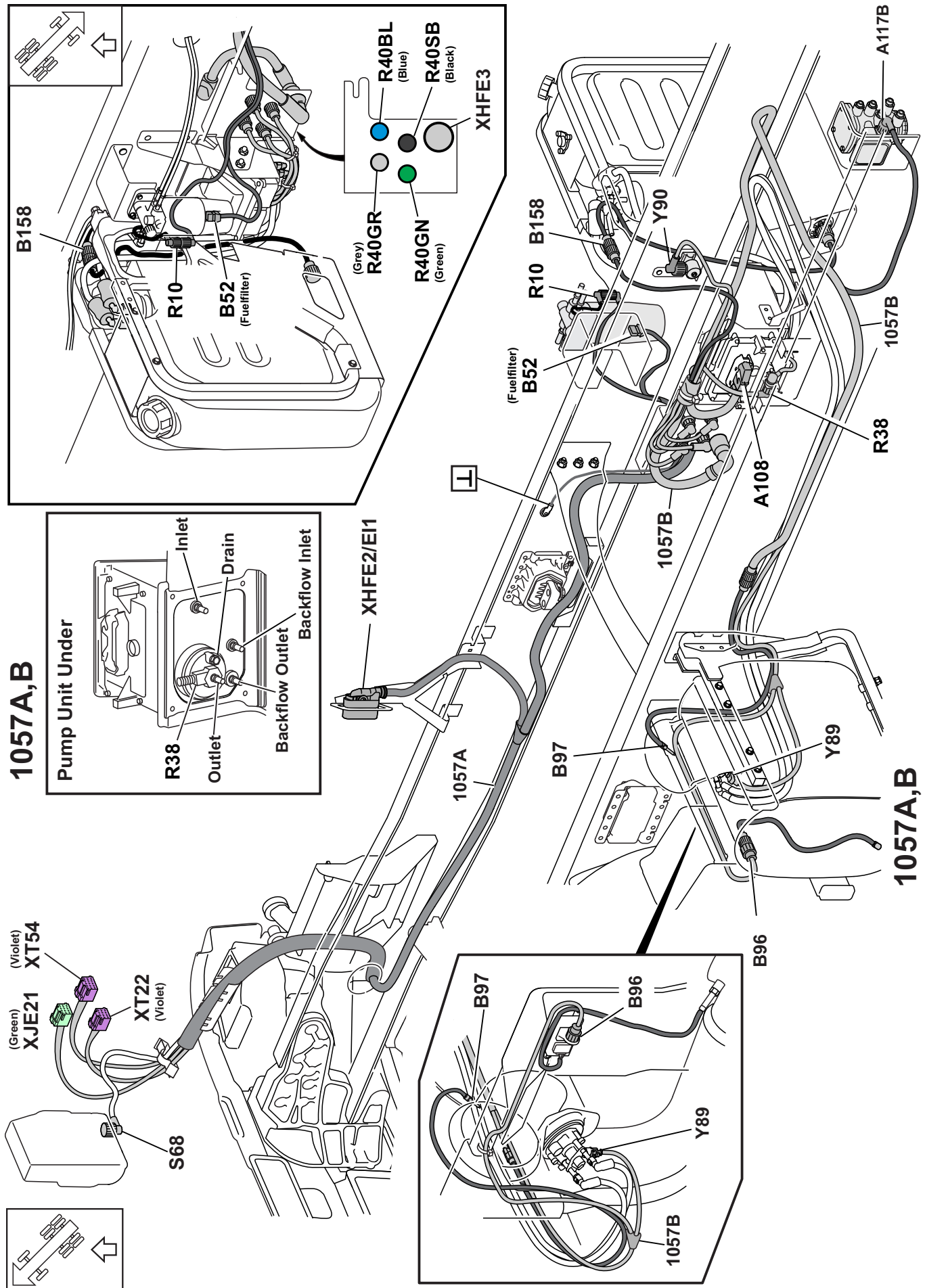

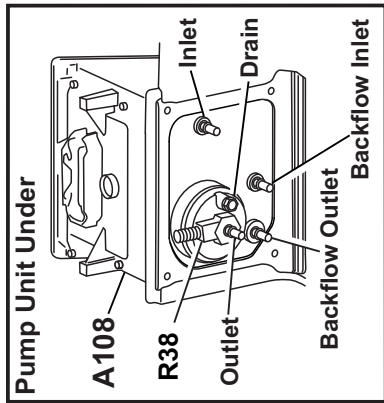
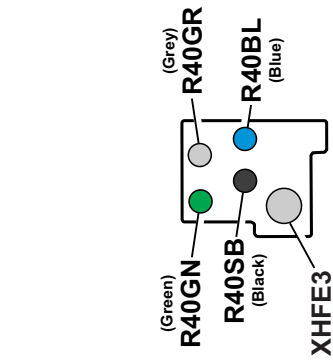
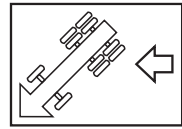

1057A,B, Hybrid

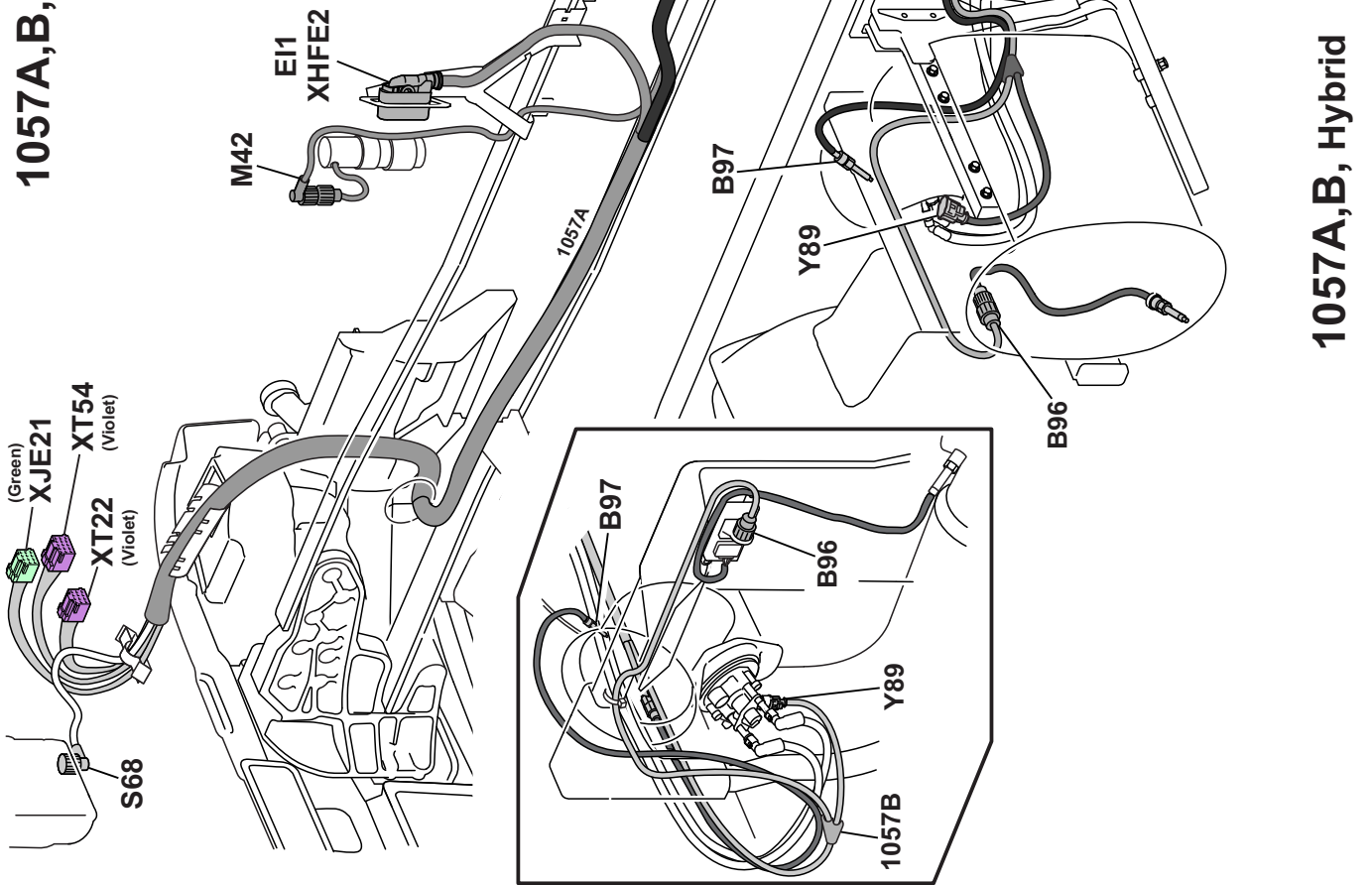

1057A,B, Hybrid

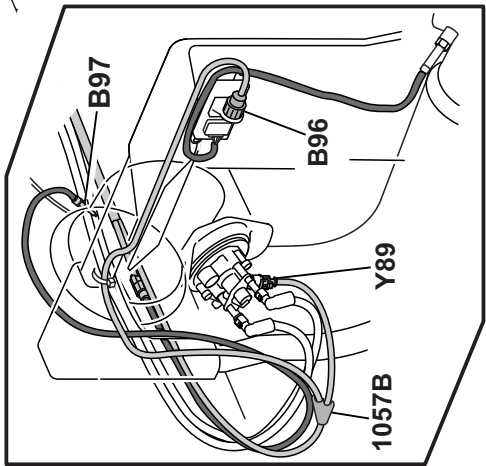

1057C, Hybrid-box

1057C, Hybrid-box

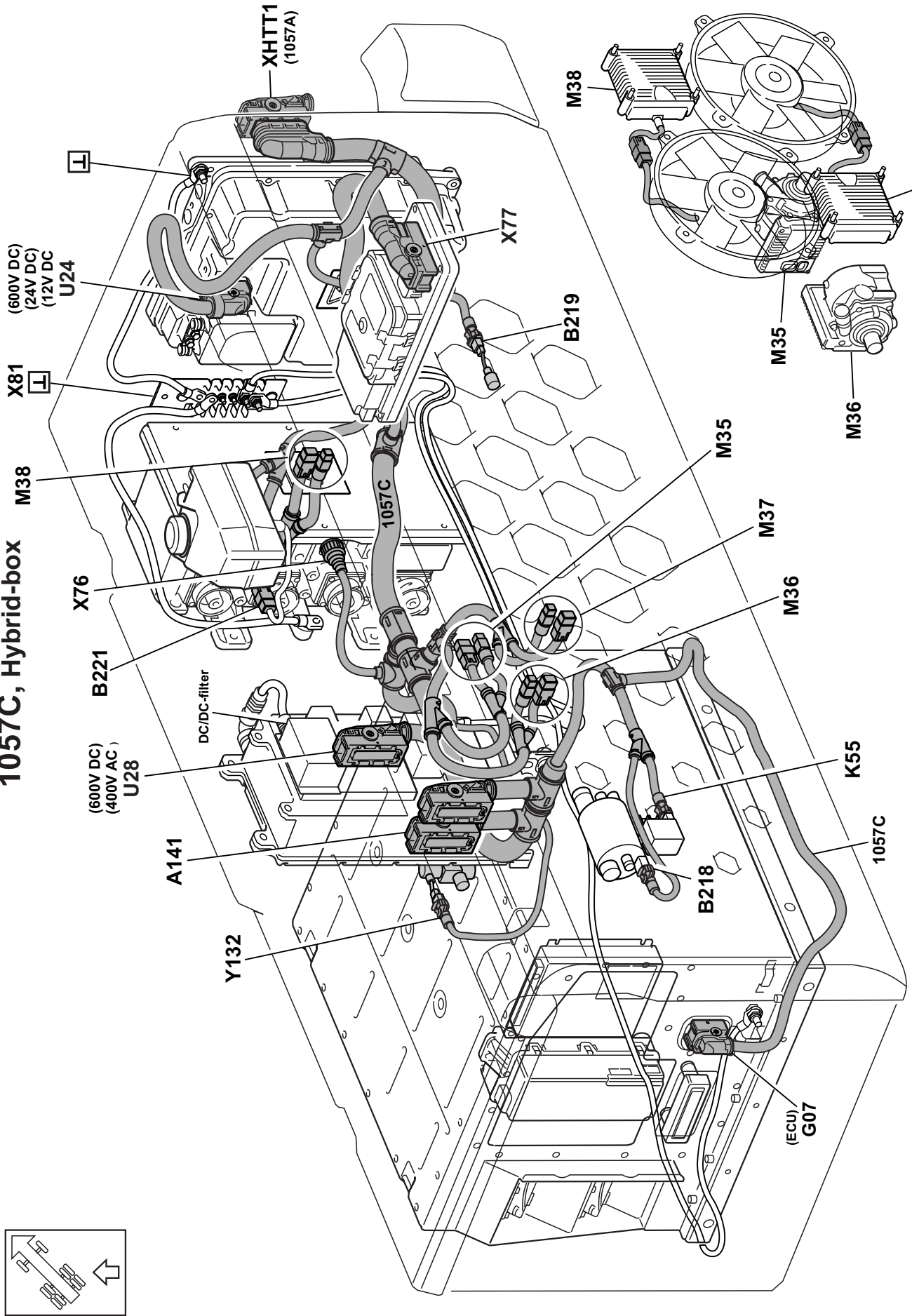

Components, Hybrid-box

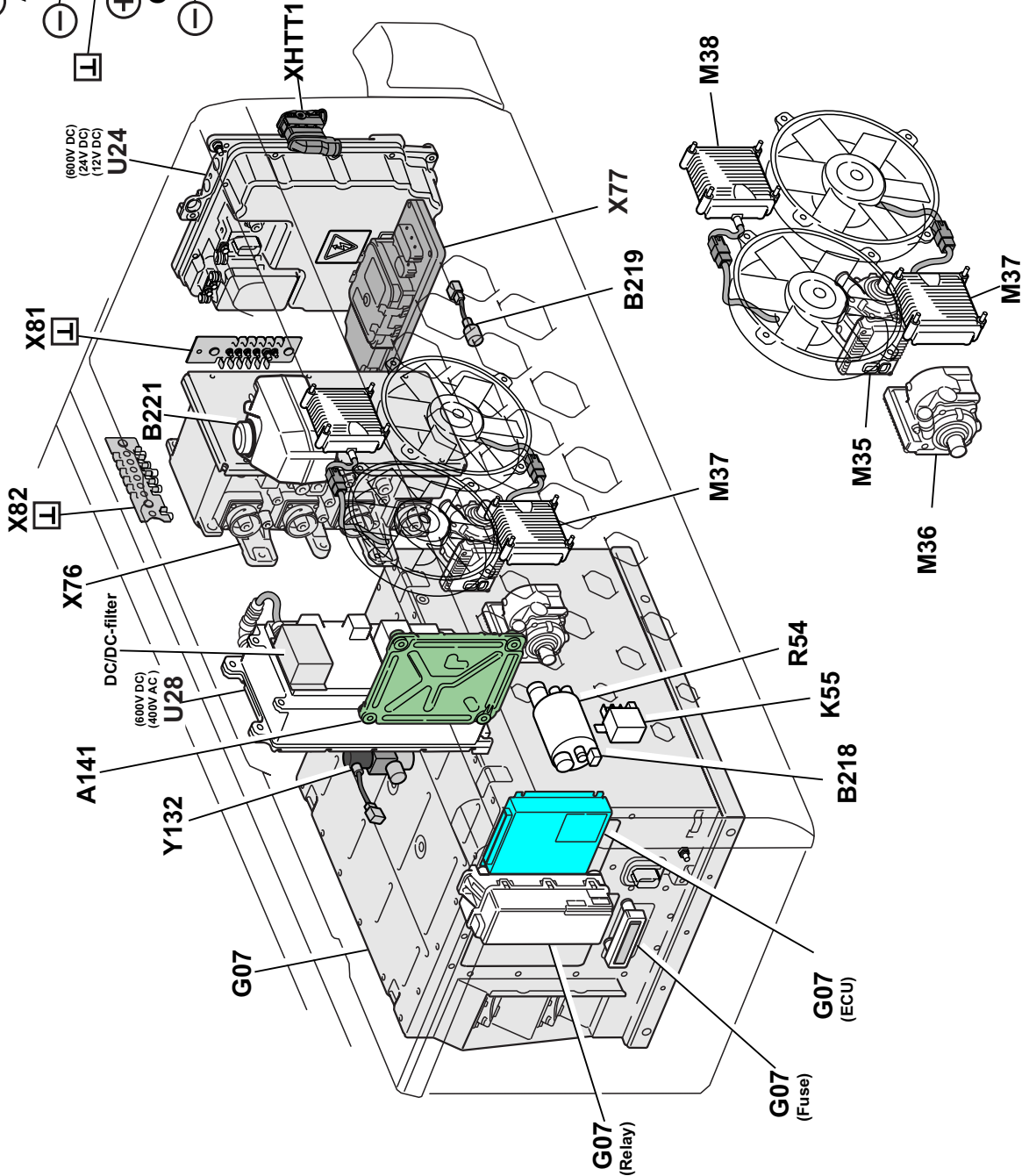
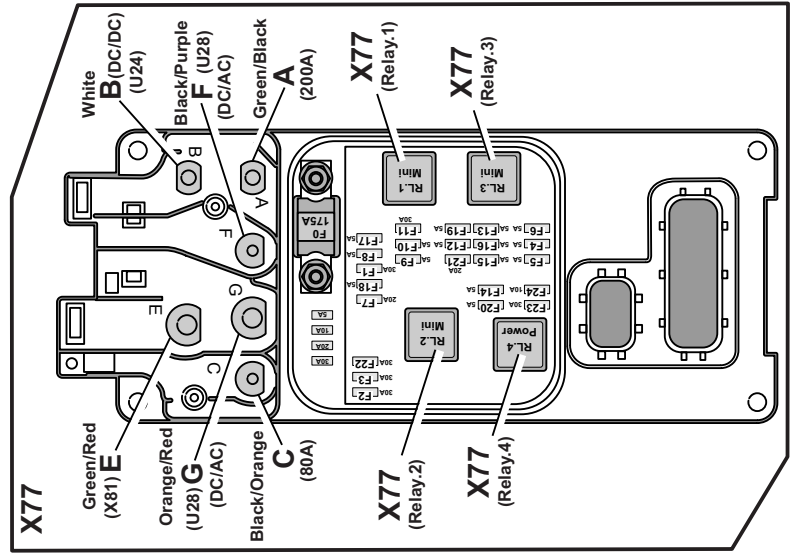
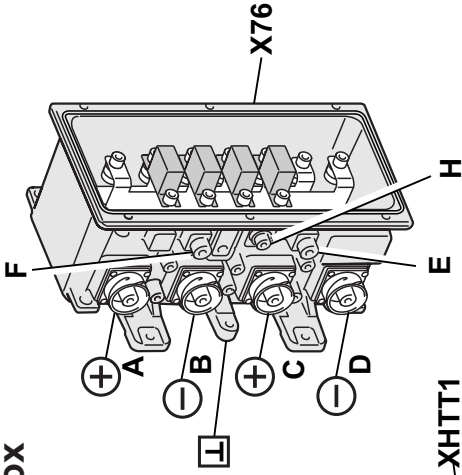
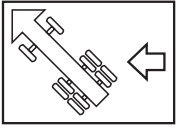

Components, Hybrid-box

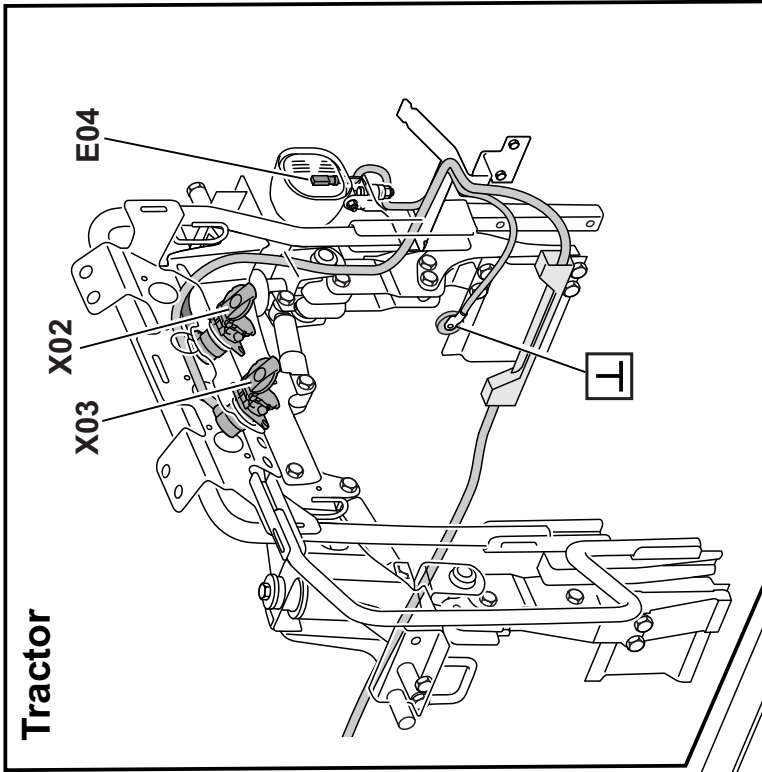
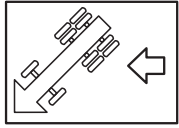

1063

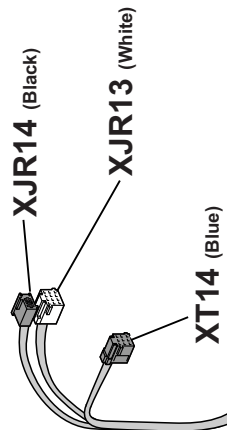

1063

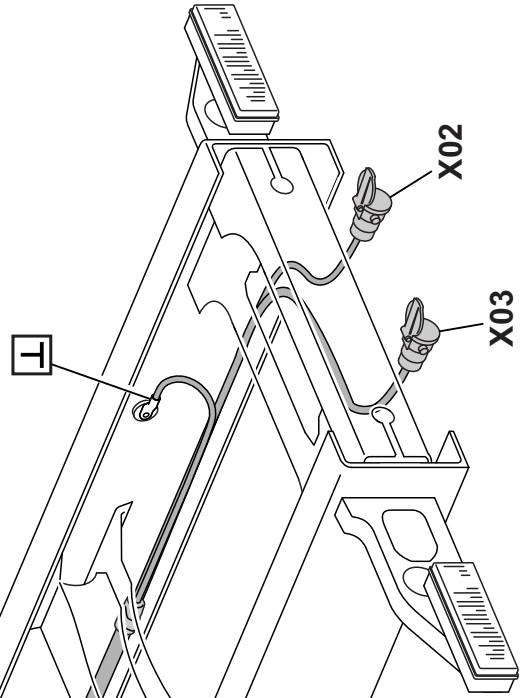

1063

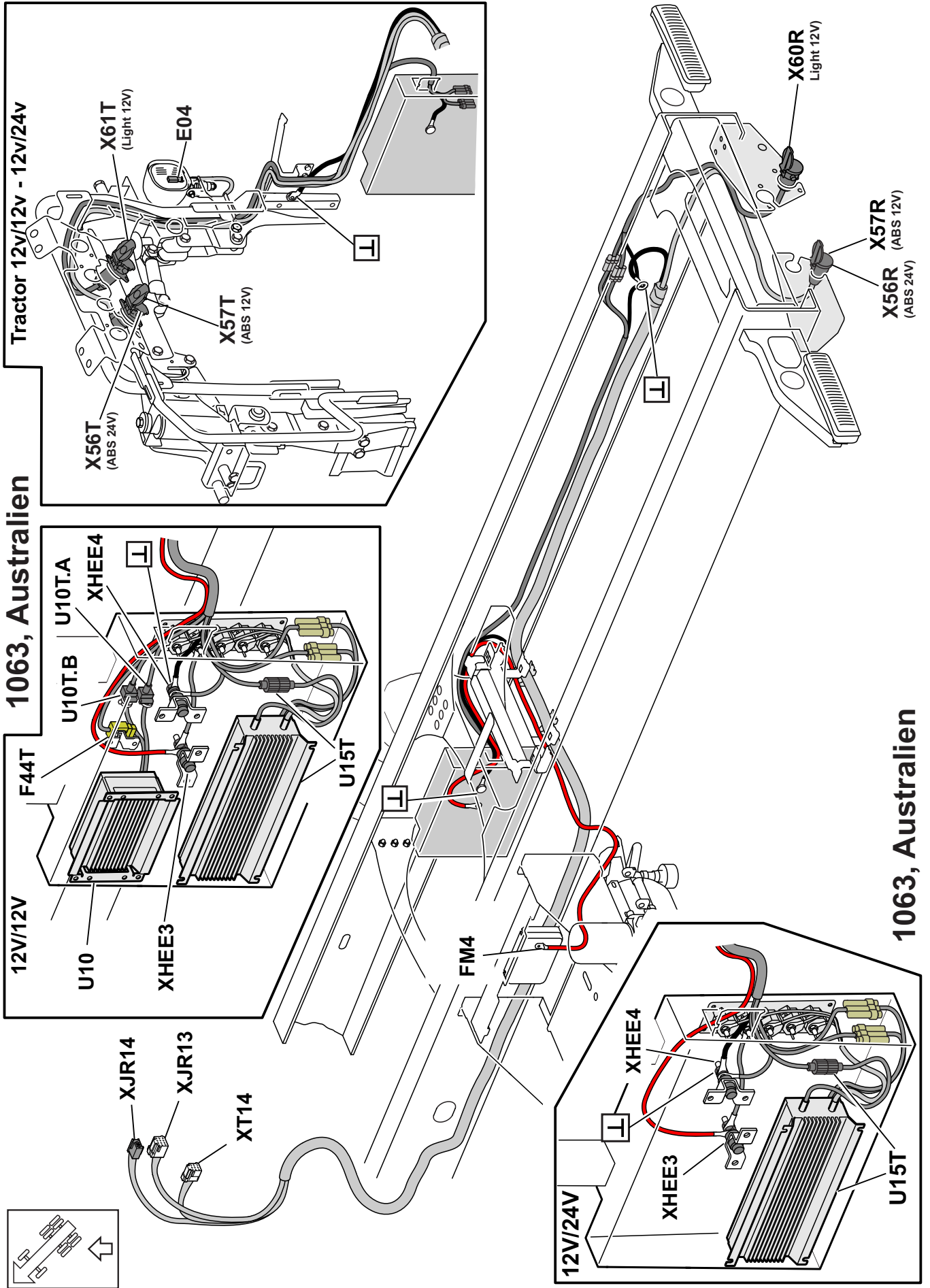

1063, Australien

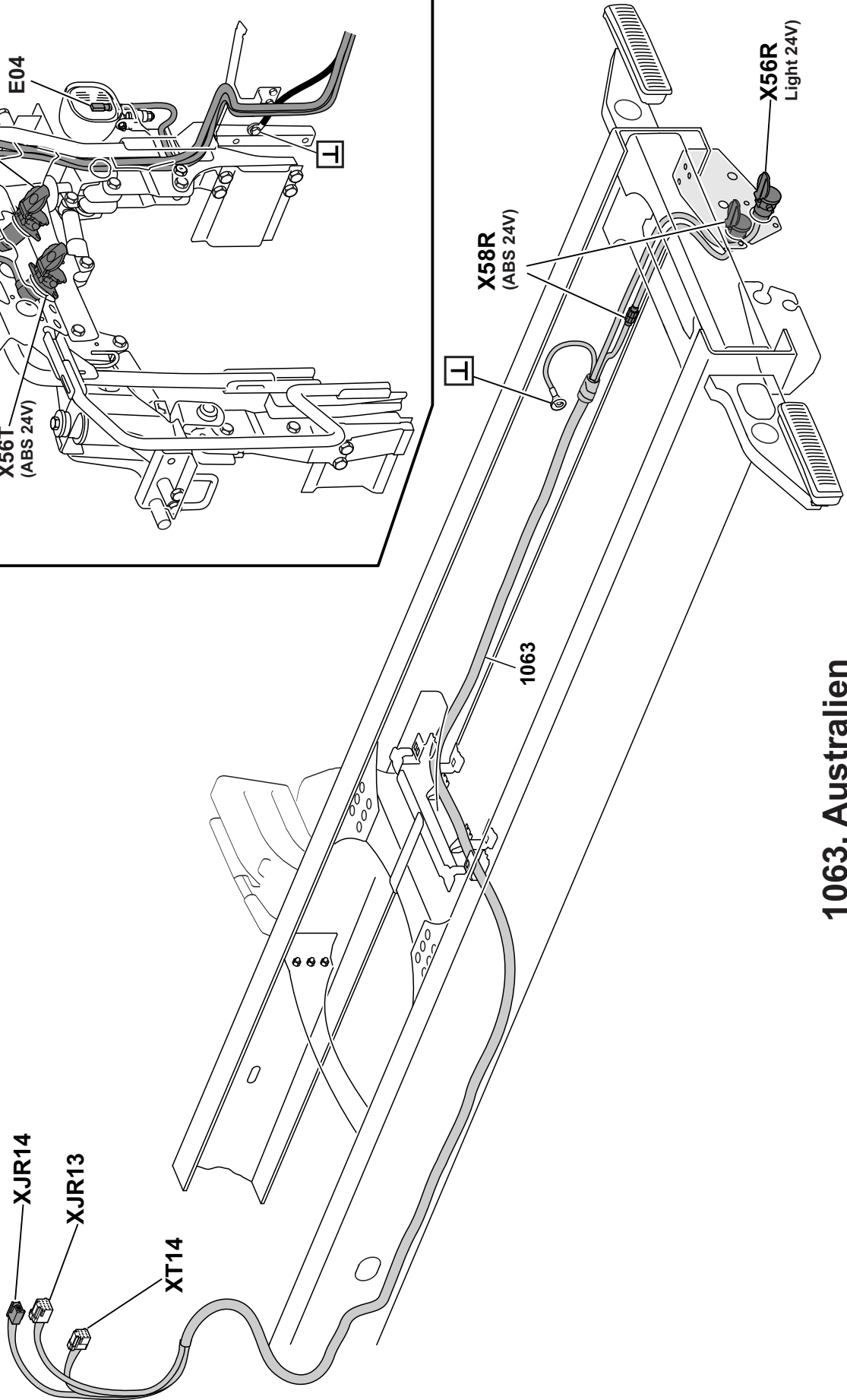
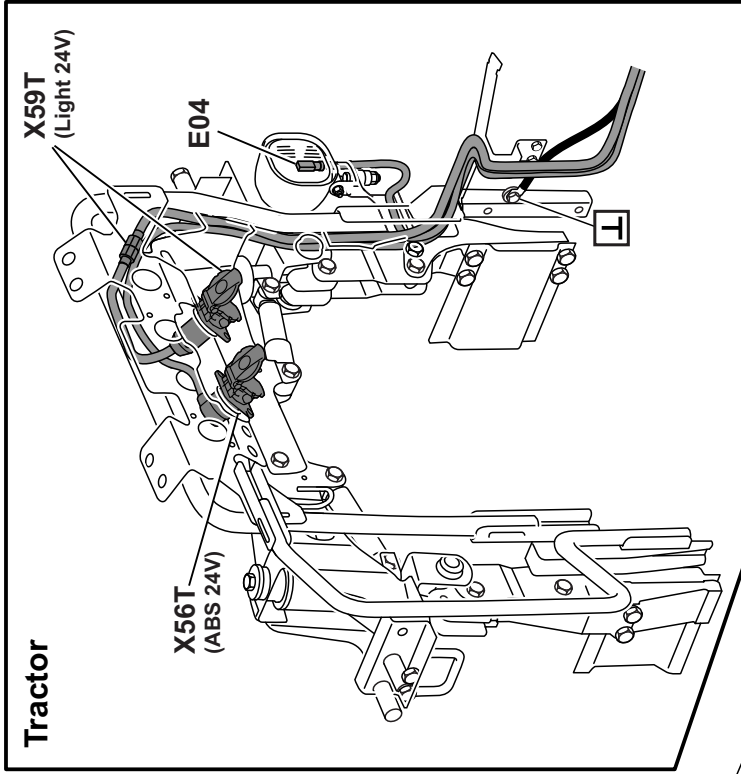
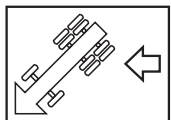

1063, Australien

STWPOS-L Drawn STWPOS-R mirror mounted

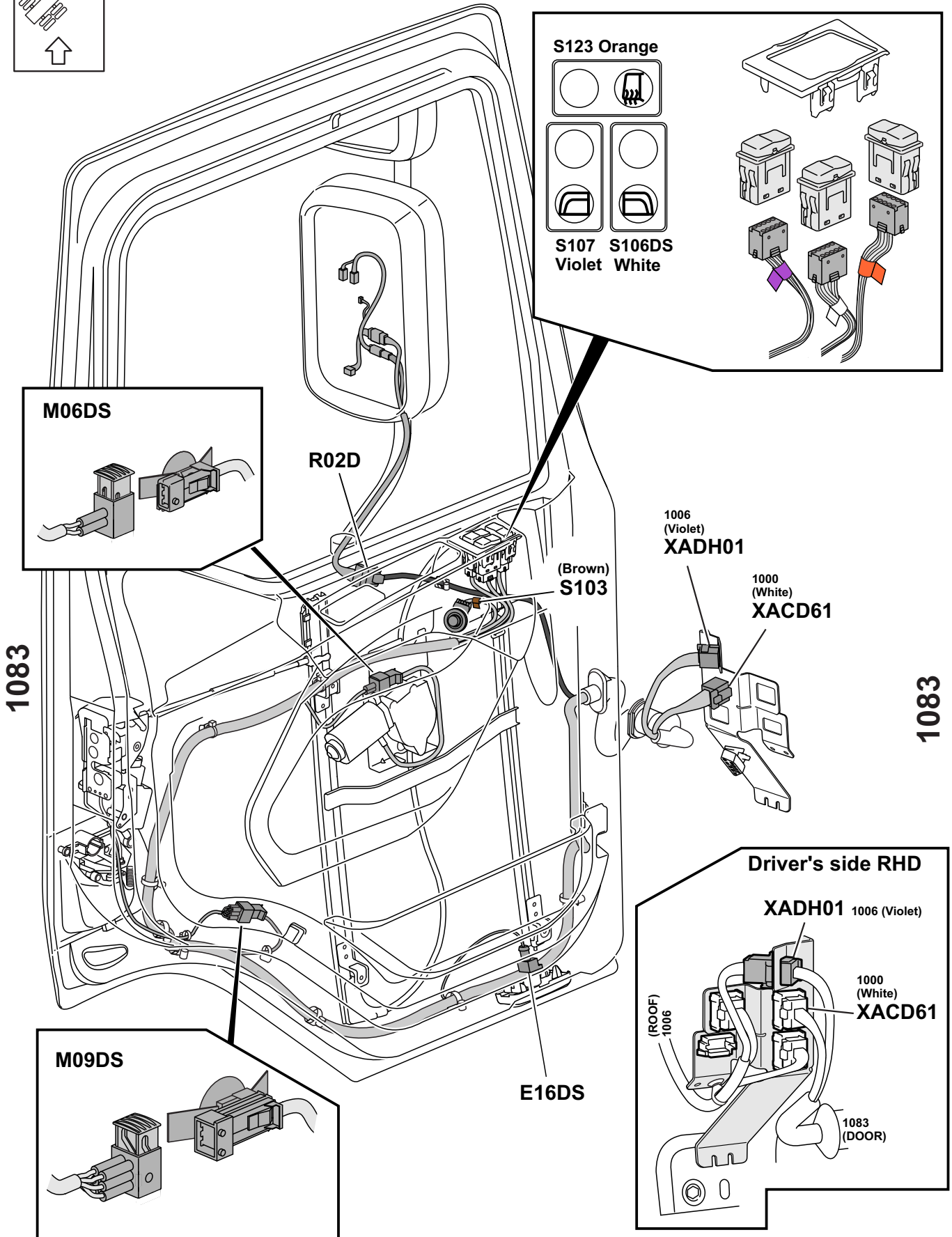
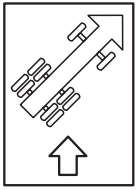

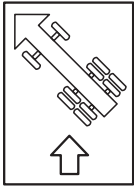

STWPOS-L Drawn STWPOS-R mirror mounted

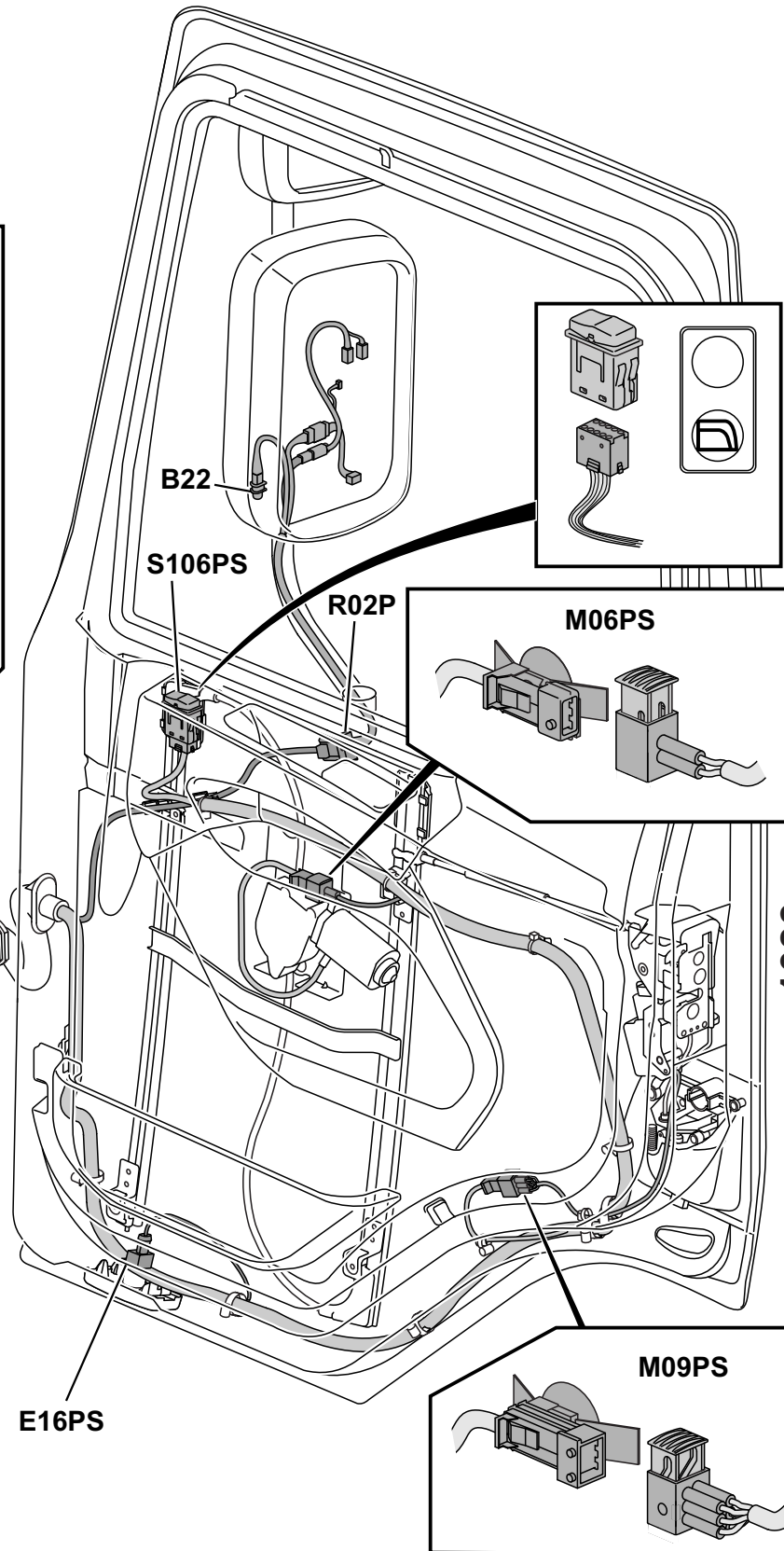
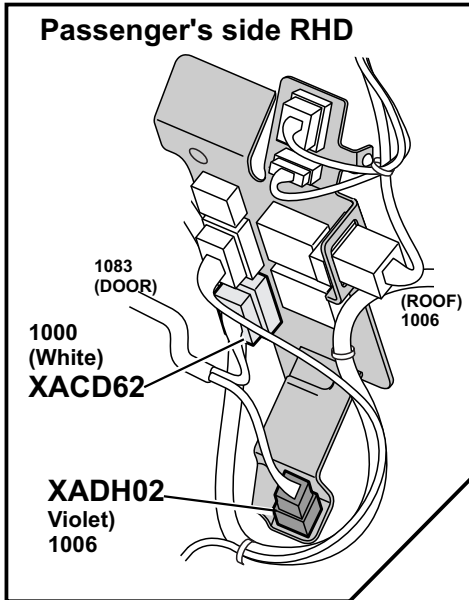

1083

1083

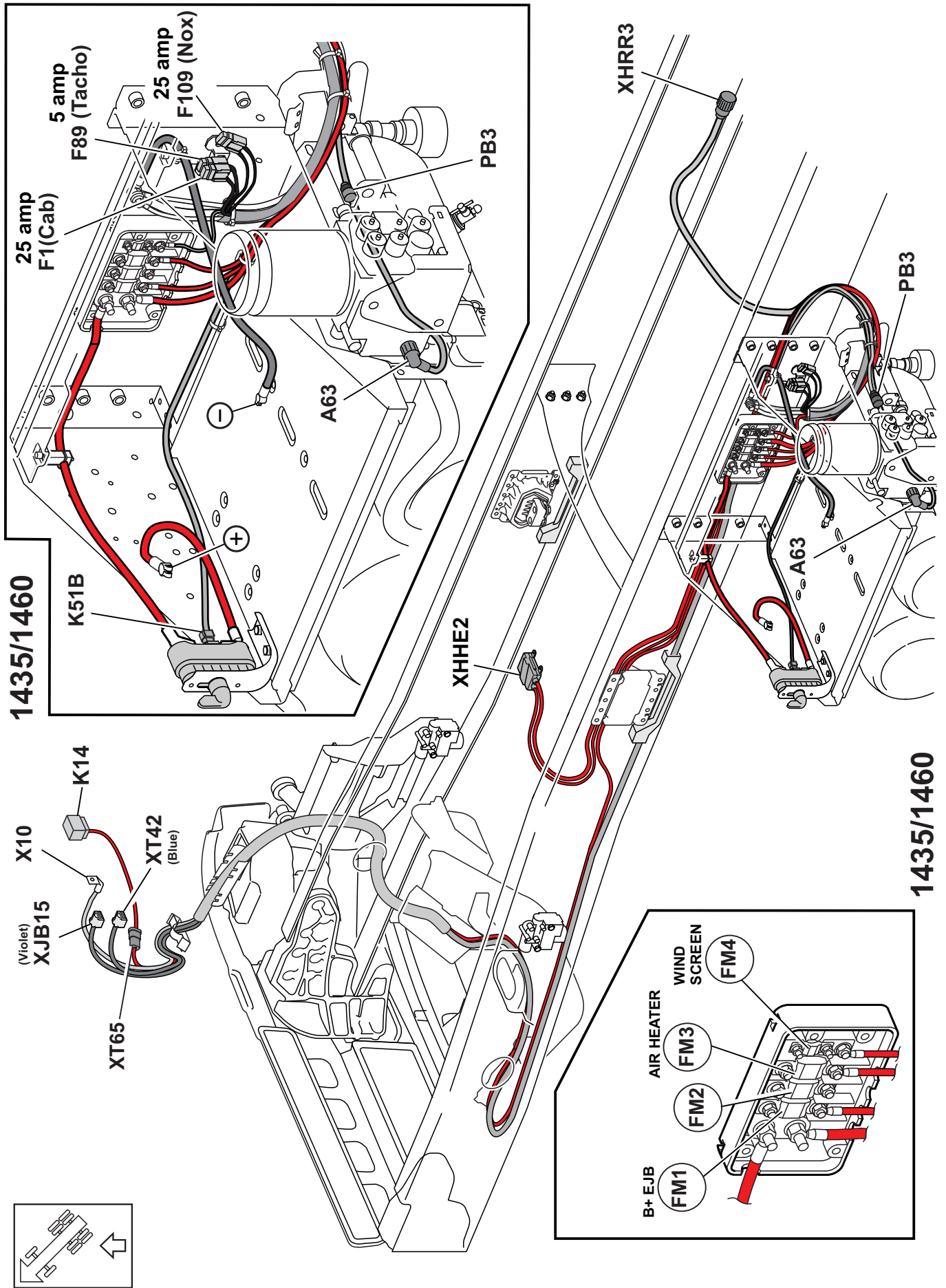

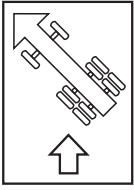

ADR

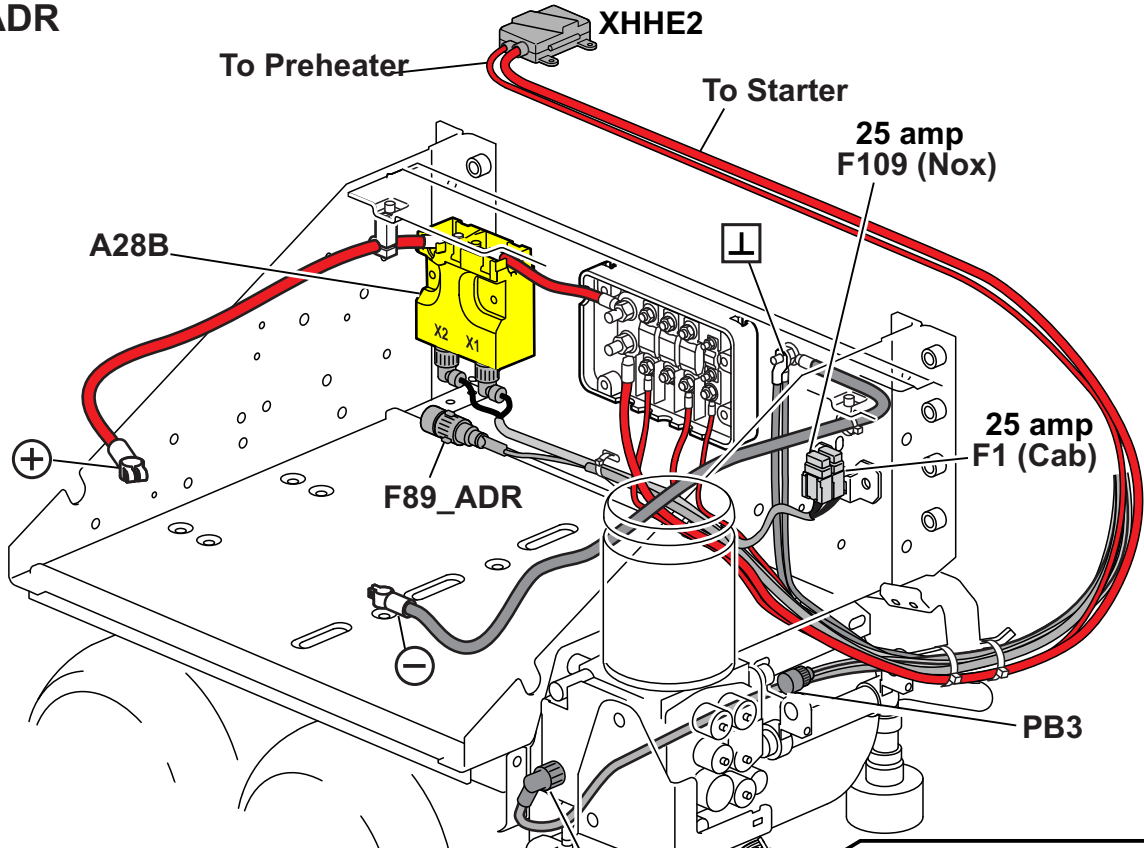

1435/1460

Lock All

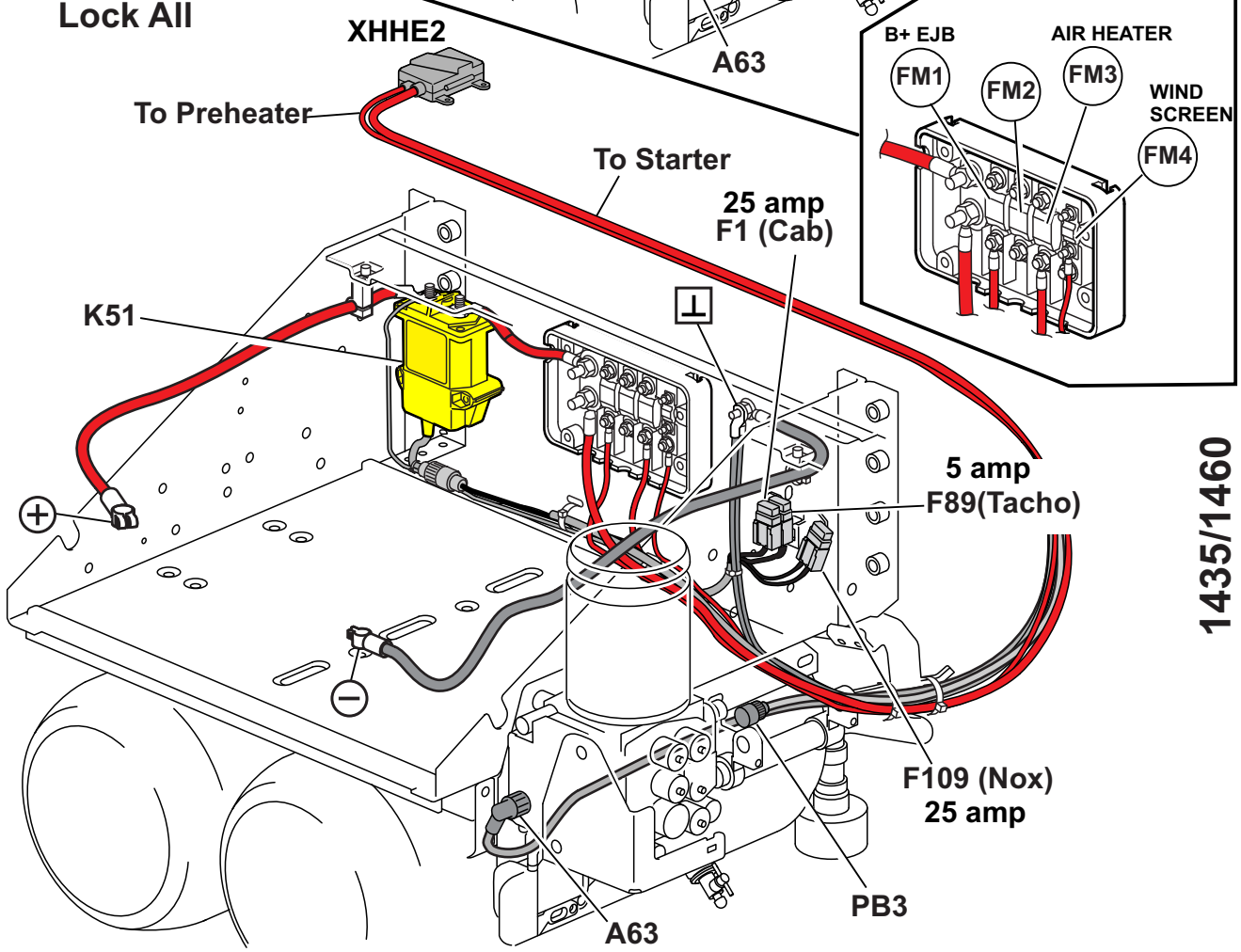

1435/1460

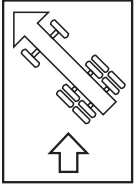

Lock All

1435/1460, Hybrid

1435/1460, Hybrid

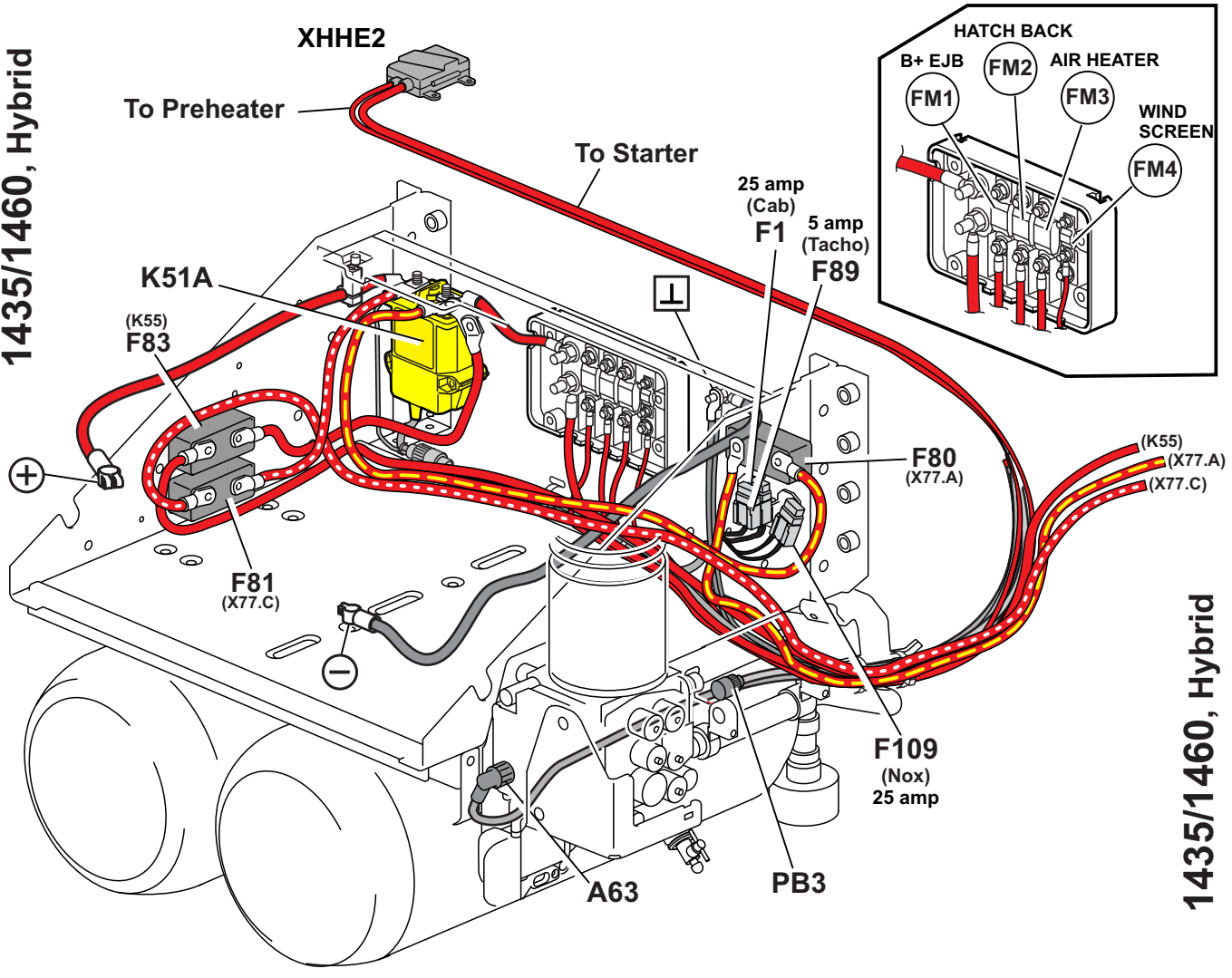

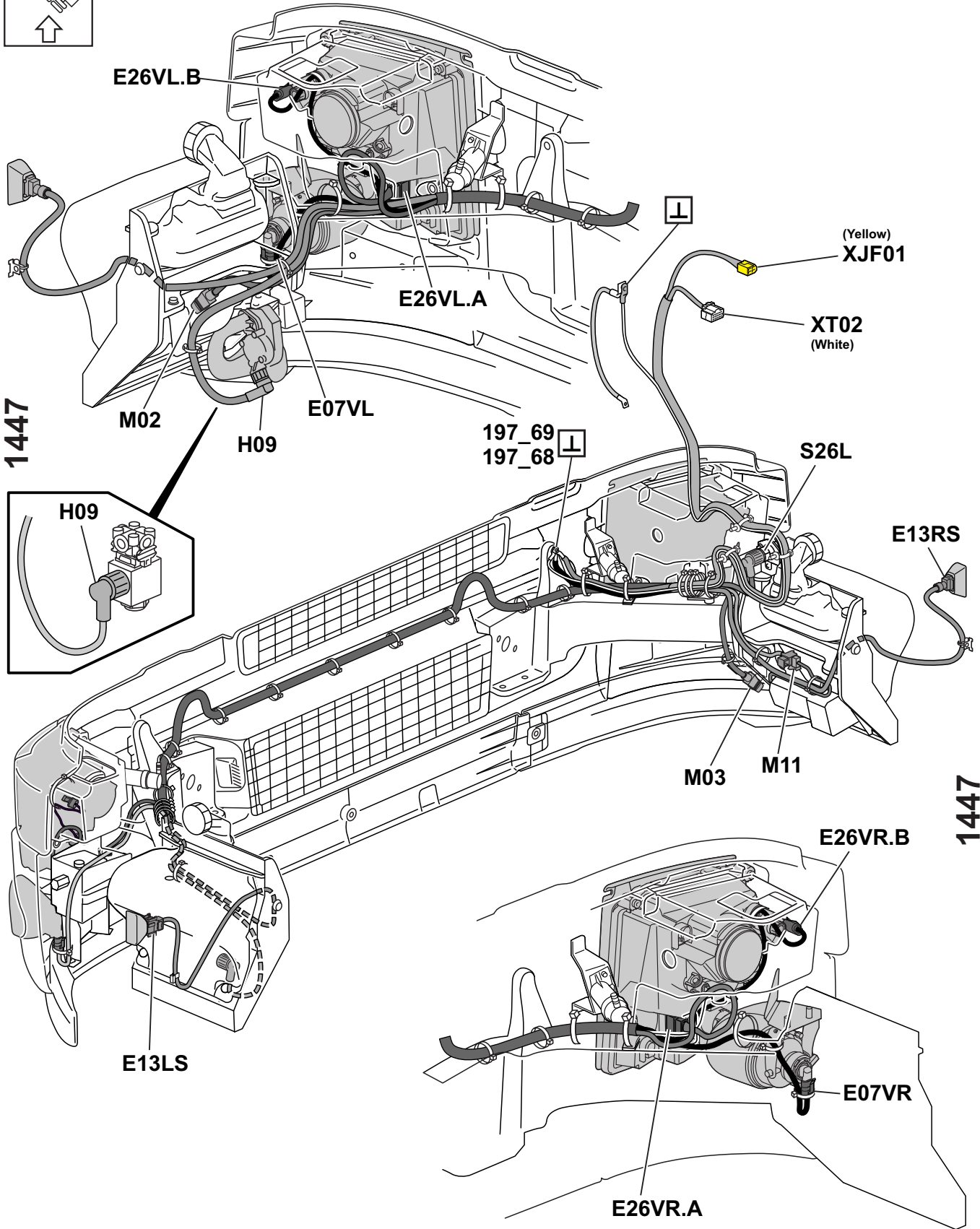
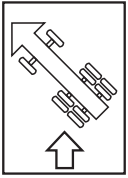

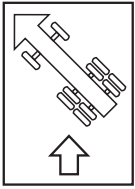

ZTO1006

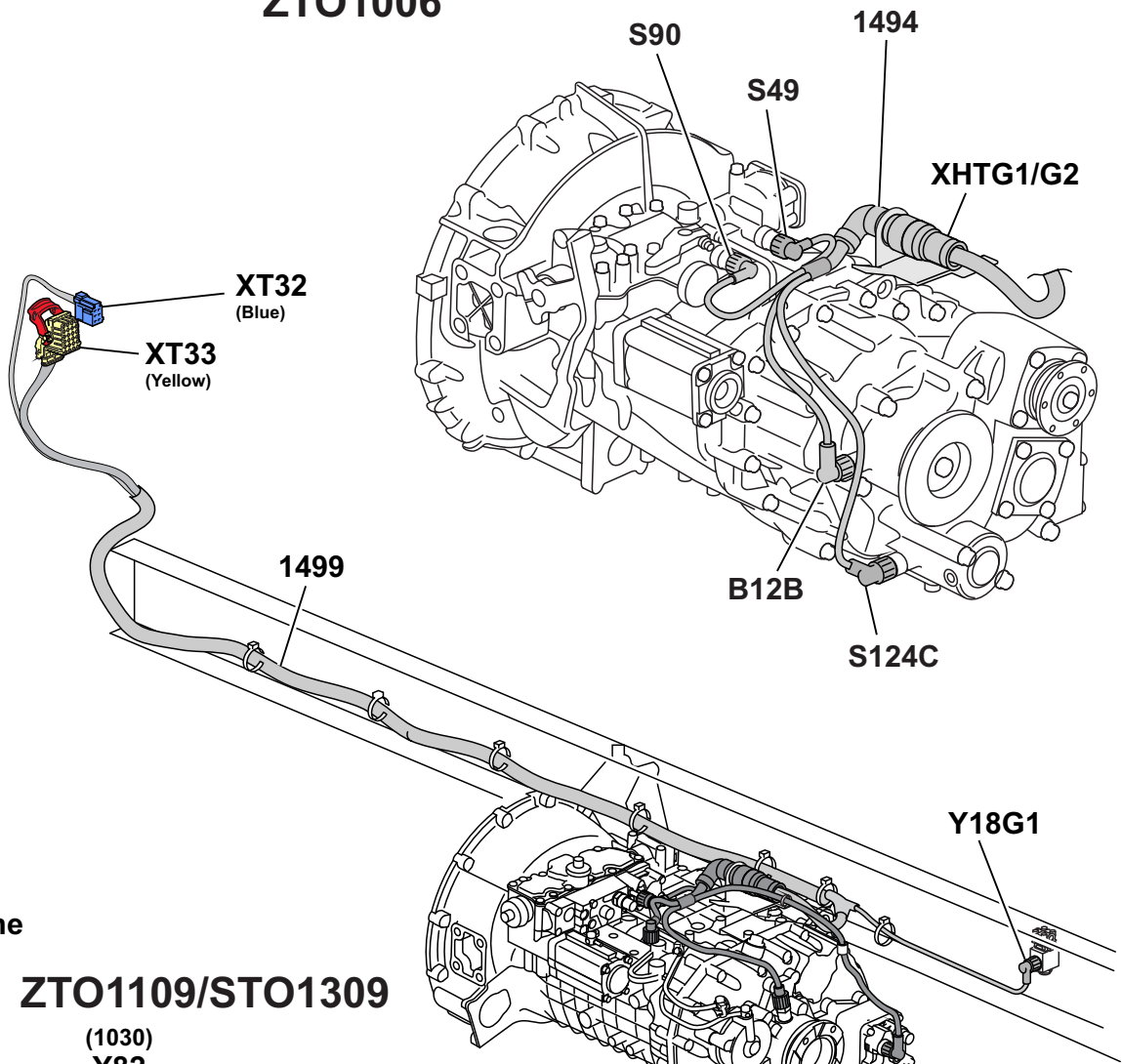

1494, 1499

(1030)
To Engine

ZTO1109/STO1309

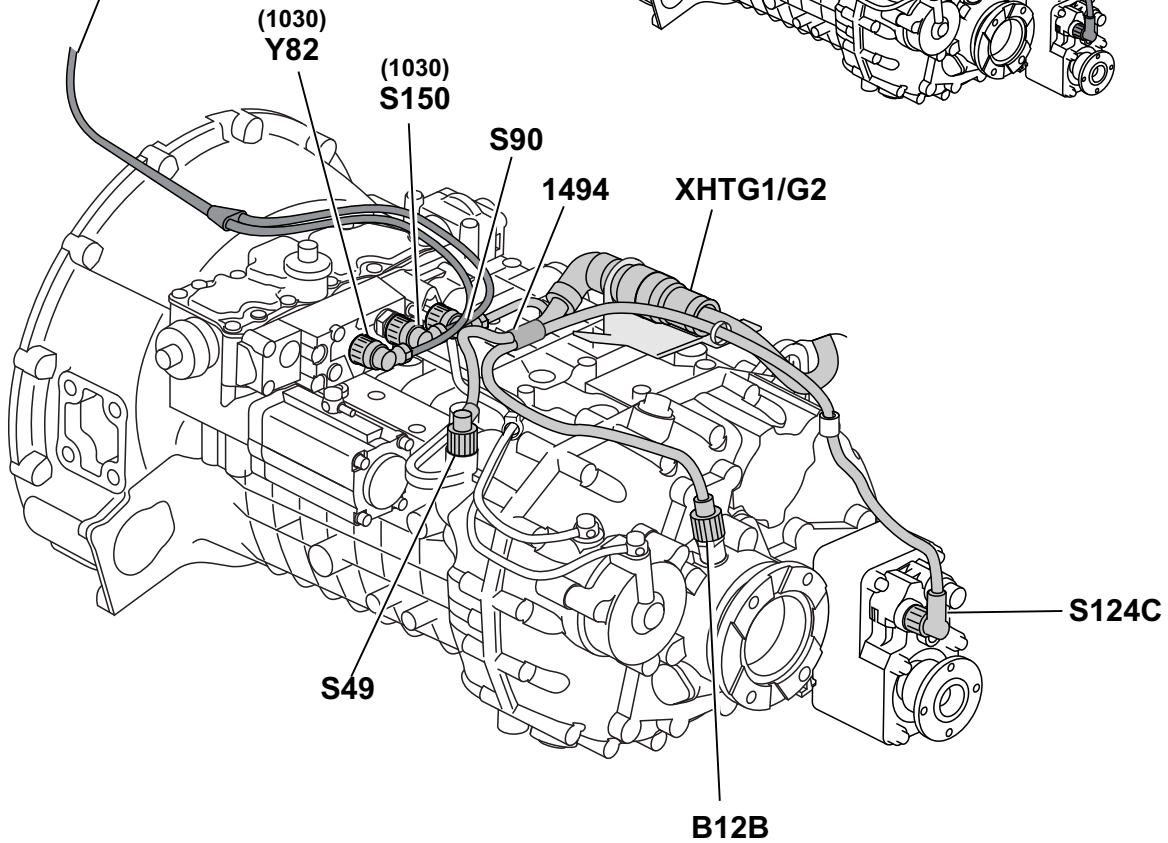

1494, 1499

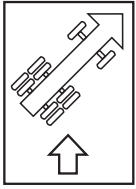

AL306, FE

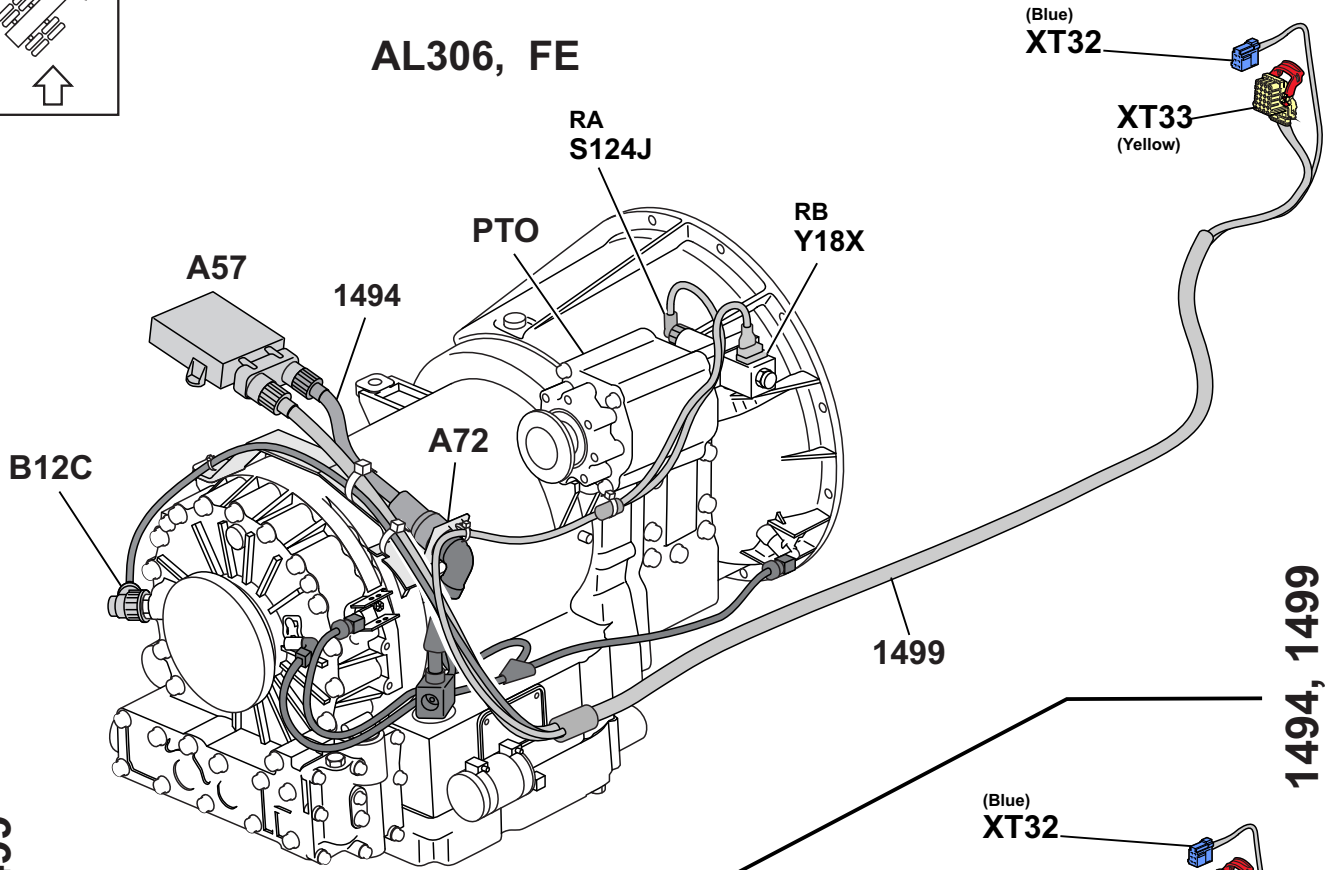

1494, 1499

1494, 1499

AL306, FL

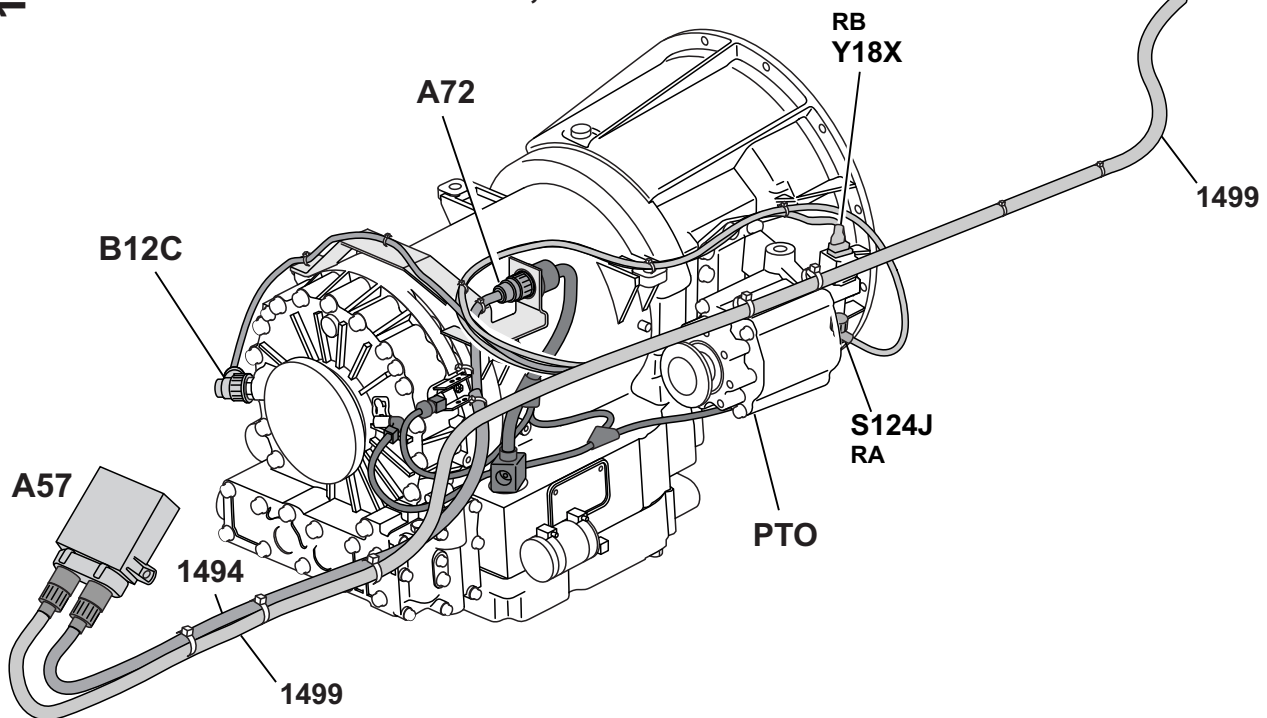

AT2412D

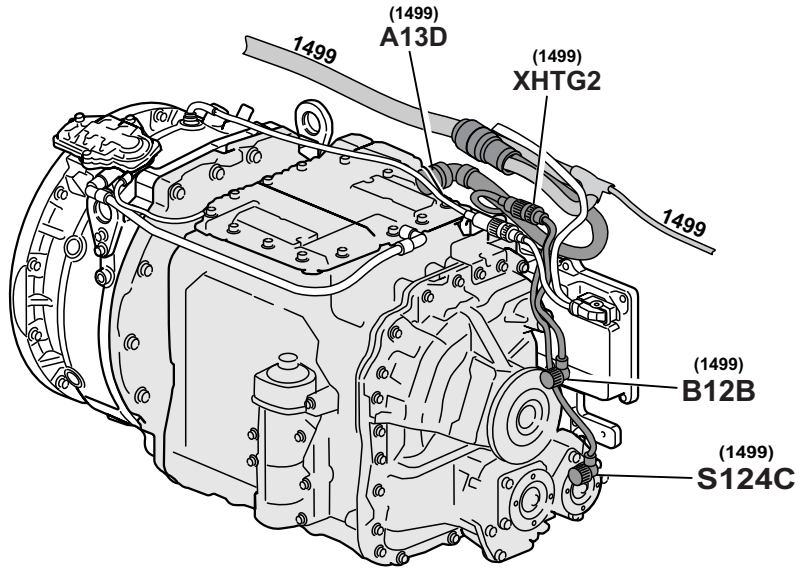
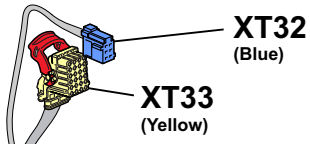
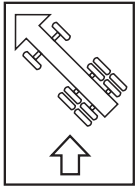

1057A, 1499

1057A, 1499

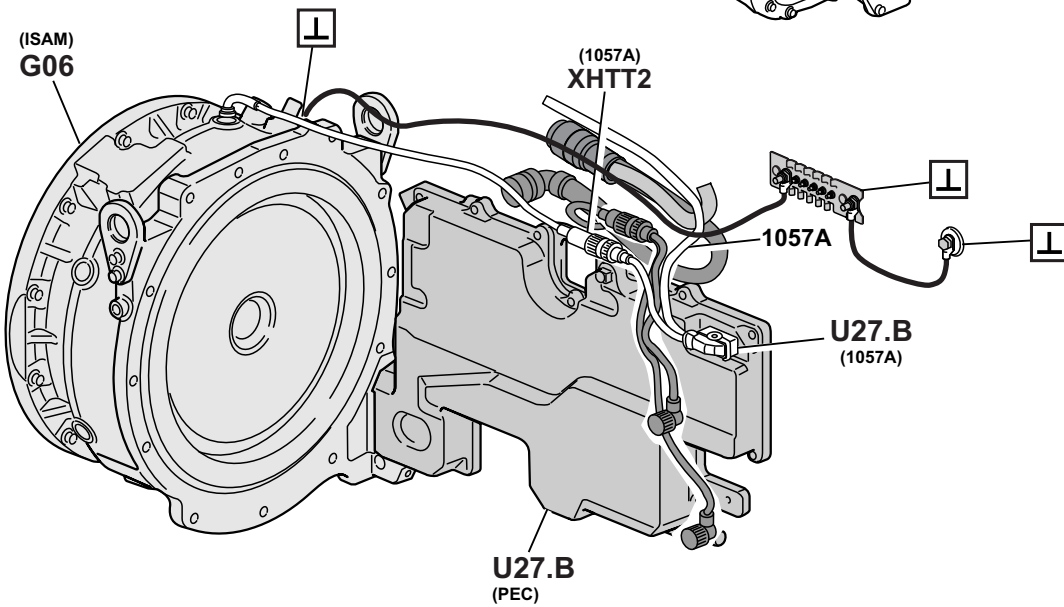
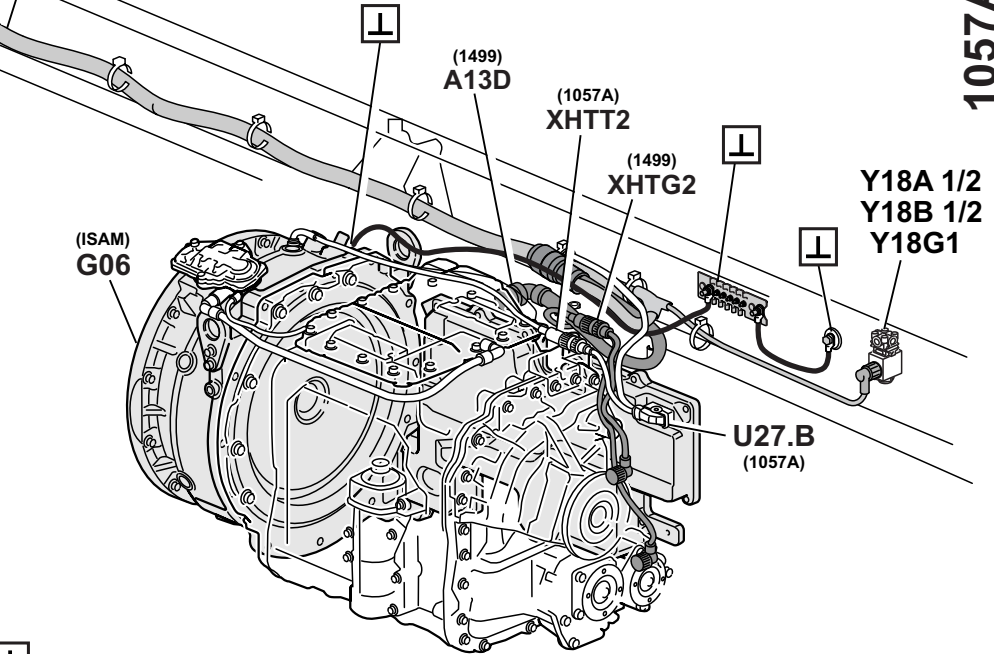

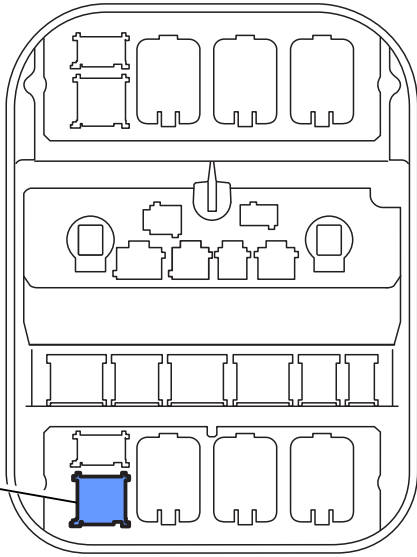
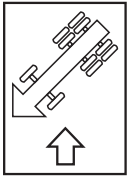

XT62
(Blue)

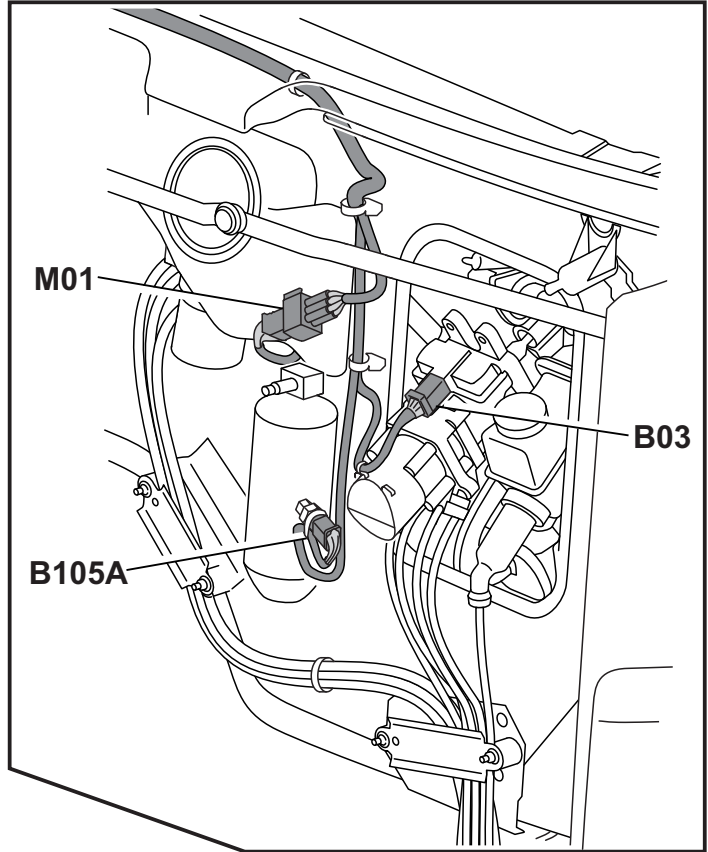

M01

B03

B105A

1501

K14

XT62

R15

XT65

B227

1501

Fuses

F1	LCM, instrument cluster, parking heater, radio, alarm, central locking (battery box).....	(AA:0 C)	F29	FMS Gateway, gear selector ECU (pos. 75).....	(AH:4 C)
F1_ADR	LCM, instrument cluster, radio, central locking (battery box).....	(AE:3 A)	F30	LCM (pos. 17).....	(GQ:1 B)
F2	Right rear window lift (pos. 42)..	(AG:3 C)	F31	Cab heater (pos. 57).....	(HJ:1 A/ HJ1:2 A/ HY:3 B)
F3	Cab tilt (pos. 74).....	(AH:2 C)	F32	Customer gloves box (Body builder) (pos. 60).....	(GA2:4 B)
F4	Instrument cluster (pos. 20).....	(BK:3 A)	F33	Not used (pos. 72).....	(KA:2 B)
F5	Motor headlamp washer pump (pos. 35).....	(GM:1 B)	F34	FMS Gateway (pos. 73).....	(BT:1 B)
F6	Instrument cluster (pos. 29).....	(AA:1 B/ AE:4 B)	F35	Not used (pos. 41).....	(AG:4 C)
F7	Vehicle ECU, tachograph (pos. 18).....	(BA:1 B)	F36	Hazard warning light, LCM (pos. 30).	(GQ:2 B)
F8	Instrument cluster, immobilizer, APM, alarm, central locking (pos. 79).....	(AI:1 C)	F37	Radio, voltage converter (pos. 63)....	(AG:2 C)
F9	BBM (pos. 19).....	(ND:2 B)	F38	Interior light, instep light (pos. 24)....	(GH1:3 A)
F10	Climate unit, cab control temp (pos. 76).....	(HY:0 B)	F39	El. adjustable rear view mirrors (pos. 3).....	(IF1:0 A)
F11	Not used (pos. 4).....	(AI:1 C)	F40	EMS 1 (pos. 44).....	(CU20:0 A)
F12	Automatic transmission (pos. 47).....	(DN:3 A/DQ1:0 A)	F41	EMS 2, single H (pos. 43).....	(CU20:0 B)
F13	Windscreen wiper (pos. 38).....	(AI:0 C)	F42	Engine preheating relay (pos. 46)....	(CU22:1 B)
F14	Cigarette lighter (pos. 45).....	(IA:3 B)	F43	24V customer plug (pos. 34).....	(IR:4 A)
F15	Diagnostic plug (pos. 70).....	(GF1:2 B)	F44	12V ABS trailer, rigid (right frame)....	(GK:1 D)
F16	Differential lock, power take off (pos. 1).....	(AJ:3 C)	F44T	12V ABS trailer, tractor (right frame) .	(GK1:1 D)
F17	Headlights, right front (pos. 37).	(GB1:1 C)	F46	Beacon warning light (pos. 61).....	(GC2:4 A)
F18	Horn (pos. 14).....	(GQ1:2 A)	F47	APM (pos. 68).....	(FC:1 A/ FC1:1 A)
F19	Climate unit (pos. 51).....	(HY:2 B)	F48	EBS (pos. 50).....	(AH:1 C)
F20	Central locking, alarm, radio (pos. 54).....	(AA:1 B/ AE:4 B)	F49	Air suspension (pos. 16).....	(FA:4 A/ FA1:4 A FA2:3 B)
F21	Trailer connection, EBS (pos. 58).....	(GF:1 A/ GK:2 A/ GK1:1 A)	F51	Rear Axle Steering Electronically Controlled (pos. 23).....	(FO:1 A)
F22	Interior lamps (pos. 48).....	(GH1:0 A/ GH3:1 A/ GH5:0 A)	F52	Key switch, immobilizer (pos. 11).....	(AB:0 A/ AE:0 B)
F23	Air suspension (pos. 2).....	(AJ:2 C)	F54	FMS connector (pos. 71).....	(BT:2 A)
F24	Fuel heater (pos. 26).....	(AJ:1 C)	F57	Driveline active (pos. 22).....	(AB_Hyb:3 A)
F25	Chassis lighting, machine control (pos. 10).....	(NB:4 A)	F58	ADR/TRS, D+ short circuit relay (pos. 6).....	(AE:2 B)
F26	Body builder (pos. 80).....	(AI:4 C)	F59	FMS, reverse lighting (pos. 5).....	(AB_Hyb:0 B/ AI:3C)
F27	Windows lift (pos. 66).....	(AG:1 C)	F61	Voltage converter DC/DC 24/12 (pos. 40).....	(AG:0 C)
F28	EBS (pos. 49).....	(EM1:3 A)	F63	Not used (pos. 65).....	(AG:4 C)
			F64	Trailer connection (pos. 28).....	(AJ:4 C)
			F66	Sun roof or left rear window lift (pos. 64).....	(AG:3 C)

F67	Automatic transmission (pos. 25).....	(AJ:2 C)	F94	Parking lighting trailer/body builder connector (pos. 53)	(GA1:3 C)
F68	Voltage converter (pos. 78)	(IR:3 A)	F96	Parking light, dashboard lights (pos. 9)	(GA2:1 B)
F70	Trailer EBS (pos. 81).....	(AI:0 C)	F97	Parking light, customer gloves boxes (pos. 7)	(GA2:4 B)
F71	Body builder connector on cab (pos. 39)	(AI:4 C)	F100	Front fog lights, high beam (pos. 21).	(GB2:0 A)
F72	Headlights, left front, instrument cluster (pos. 36).....	(GB1:2 C)	F101	Rear fog lights (pos. 15).....	(GB2:2 C)
F75	El. heated seat, buzzer belt, BBM connector (pos. 32)	(AB:4 C/ AE:4 C)	F102	Horn (pos. 62)	(GQ1:1 C)
F76	Horameter (pos. 8)	(AB:3 C/ AE:3 C)	F103	Reverse lights (pos. 33)	(GD:1 A)
F77	Body builder connector (pos. 69)	(NA:1 A)	F104	Brake lights (pos. 13)	(GD:3 A)
F80	Junction box, Hybrid (1435/1460).....	(AB_Hyb:2 D)	F105	Not used (pos. 31).....	(AA:2 B/ AE:4 B)
F81	Junction box, Hybrid (1435/1460).....	(AB_Hyb:1 D)	F106	Not used (pos. 27).....	(AJ:0 C)
F83	ESS heater (1435/1460).....	(AB_Hyb:1 B)	F107	EMS Euro4 (pos. 59).....	(CU20:0 B)
F89	Tachograph (battery box).....	(BM:1 A)	F108	Parking heater/Free (pos. 82)	(AA:0 A/ AE:3 B)
F89_ADR	Tachograph, ADR (battery box).....	(BM:2 A)	F109	NDS Euro4 (battery box)	(CU23:2 B)
F90	Stalk switch (pos. 12)	(GA1:3 A)	FM5	Fuse group (battery box)	(AA:3 B/ AC:3 C)
F91	Parking light, left rear lights (pos. 56)	(GA1:0 C)			
F92	Parking light, right rear lights (pos. 55)	(GA1:1 C)			
F93	Parking lighting trailer/body builder connector (pos. 52)	(GA1:3 C)			

Relays

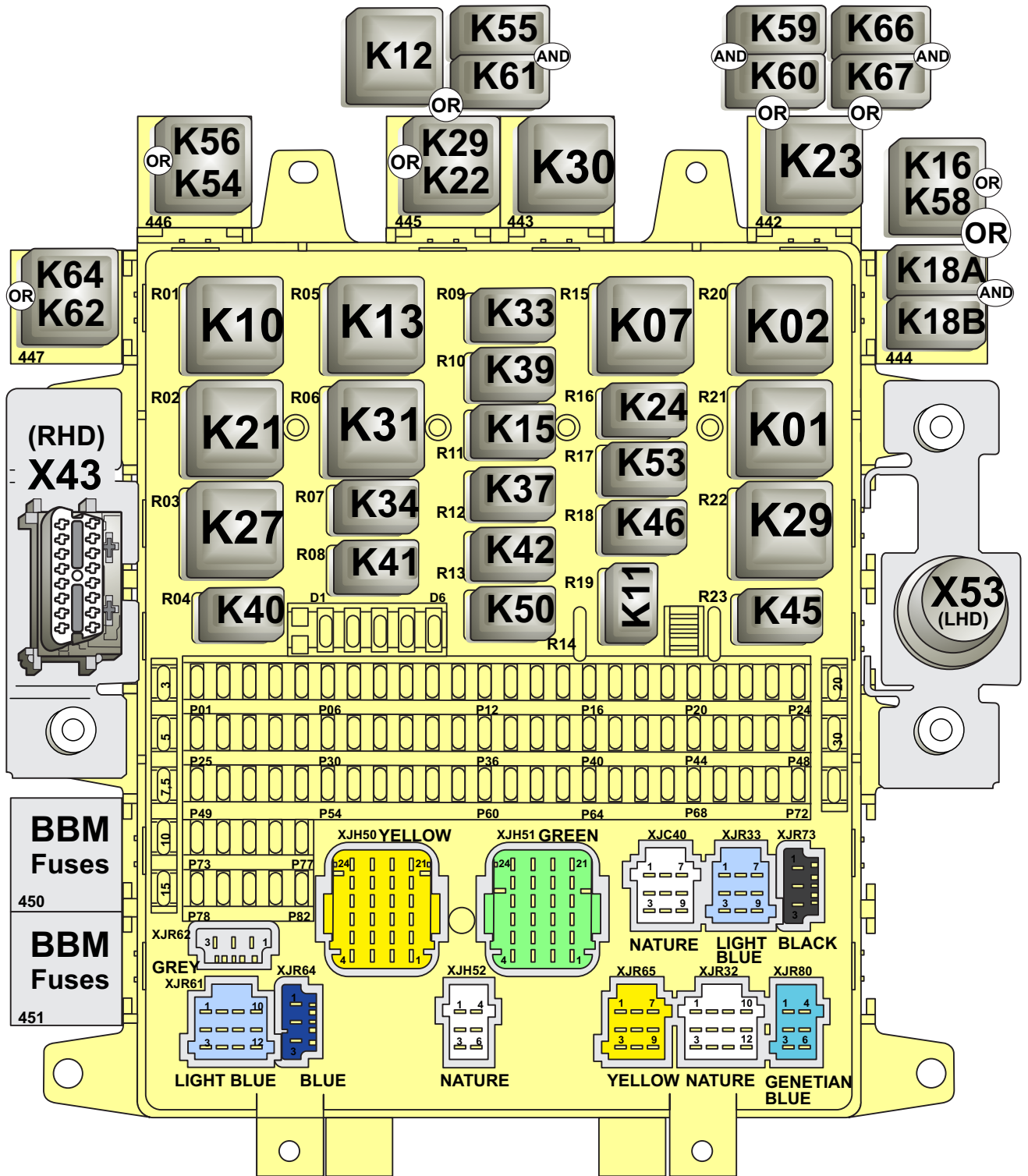

Relays

K1	Relay ,starting switch, accessories (pos. 21).....	(AG:0 B)	K34	Relay ,interior parking lights (pos.7).	(GA2:1 B)
K2	Relay ,EMS (Engine Management System), tachograph (pos.20).....	(BA:1 A)	K37	Relay ,parkinglight (pos.12).....	(GA1:2 C)
K7	Relay ,intermittent wiper (pos.15)....	(GM:2 C)	K39	Relay ,alternator shut down/water heater (pos.10).....	(AB_Hyb:0 D/ AE:1 D)
K10	Relay ,power supply kl.15 (pos.1)....	(AH:0 A)	K40	Relay, heated adjustable mirror (pos 4)	(IF1:2 B).
K11	Relay ,air suspension (pos.19).....	(FA:4 B/ FA1:4 B/ FA2:3 B)	K41	Relay, reverse light (pos. 8).....	(GD:1 B)
K12	Relay ,compressor magnetic clutch (pos. 445)	(HY:3 C)	K42	Relay, brake light (pos. 13).....	(GD:3 B)
K13	Relay ,alternator controlled (pos.5)..	(AB:3 D/ AE:2 D)	K45	Relay, front fog light (pos. 23)	(GB2:1 B)
K14	Relay ,windscreen heater (1501).....	(IF1:4 B)	K46	Relay, rear fog light (pos. 18)	(GB2:3 B)
K15	Relay ,park break trigger (pos.11)....	(KA:1C)	K48	Power relay, engine preheating (engine)	(CU22:2 C)
K16	Relay ,body builder machine on.....	(NB:3 C)	K50	Relay, horn (pos. 14).....	(GQ1:1B)
K18	Relay ,driveline active.....	(AB_Hyb:3 B)	K51	Power relay, battery main switch (1435/1460)	(AA:1 C)
K21	Relay ,power supply kl.15 (pos.2)....	(AB_Hyb:0 A/ AI:0 B)	K51B	Power relay, battery main switch (1435/1460)	(AA:1C)
K23	Relay ,cab tilt (pos.442).....	(KA:2 B)	K51_Hyb	Power relay, battery main switch (1435/1460).....	(AB_Hyb:1 C)
K24	Relay ,automatic transmission (pos. 16)	(DN:3 B/ DQ1:1 B)	K53	Relay, starter control (pos. 17)	(CU22:0B)
K27	Relay ,power supply kl.15 (pos.3)....	(AJ:0 B)	K54	Relay, motor headlamp washer pump (pos. 446)	(GM:1 C)
K29	Relay ,accessories (pos.22).....	(AG:3 B)	K55	Relay, ESS heater (1057C)	(AB_Hyb:1 B)
K30	Relay ,beacon warning light (pos.443)	(GC2:3 C)			
K31	Relay ,parking lighting trailer/body builder connector (pos.6).....	(GA1:4 C)			
K33	Relay ,highbeam headlight (pos.9)..	(GB1:3 C)			

Wiring harness illustration index

1000	Wiring harness, instruments.....	“”, page 110
1006	Wiring harness, roof	“”, page 115
1007	Wiring harness, floor	“”, page 119
1030	Wiring harness, engine	“”, page 121
1040	Wiring harness, frame	“”, page 123
1047	Wiring harness, roof beacon light	“”, page 129
1057	Wiring harness, chassis	“”, page 130
1063	Wiring harness, trailer connections.....	“”, page 134
1083	Wiring harness, door	“”, page 137
1435	Wiring harness, main switch	“”, page 139
1447	Wiring harness, bumpers	“”, page 142
1460	Wiring harness, cab-battery box.....	“”, page 139
1494	Wiring harness, gearbox	“”, page 143
1499	Wiring harness, cab-gearbox.....	“”, page 143
1501	Wiring harness, upper front	“”, page 146

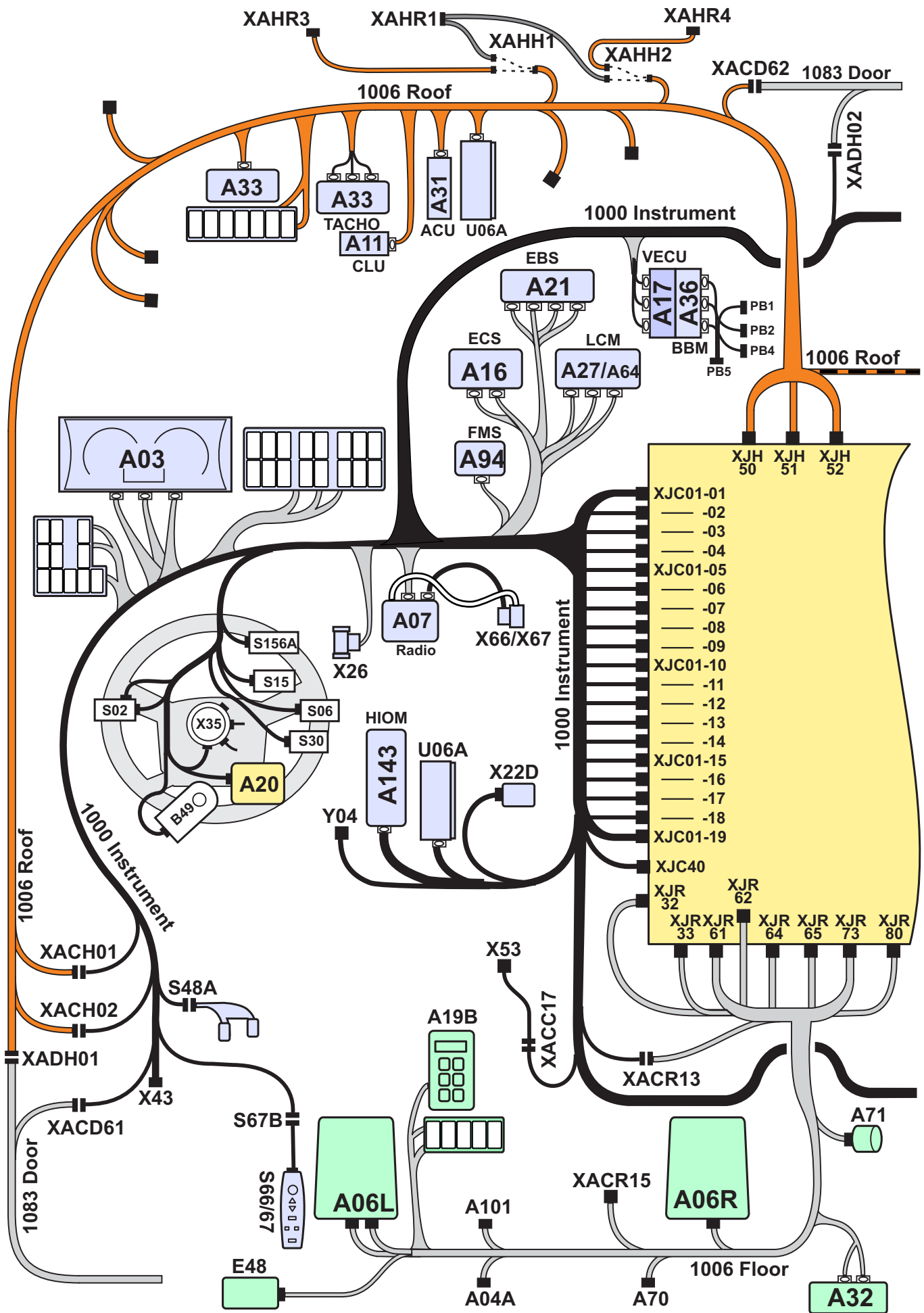

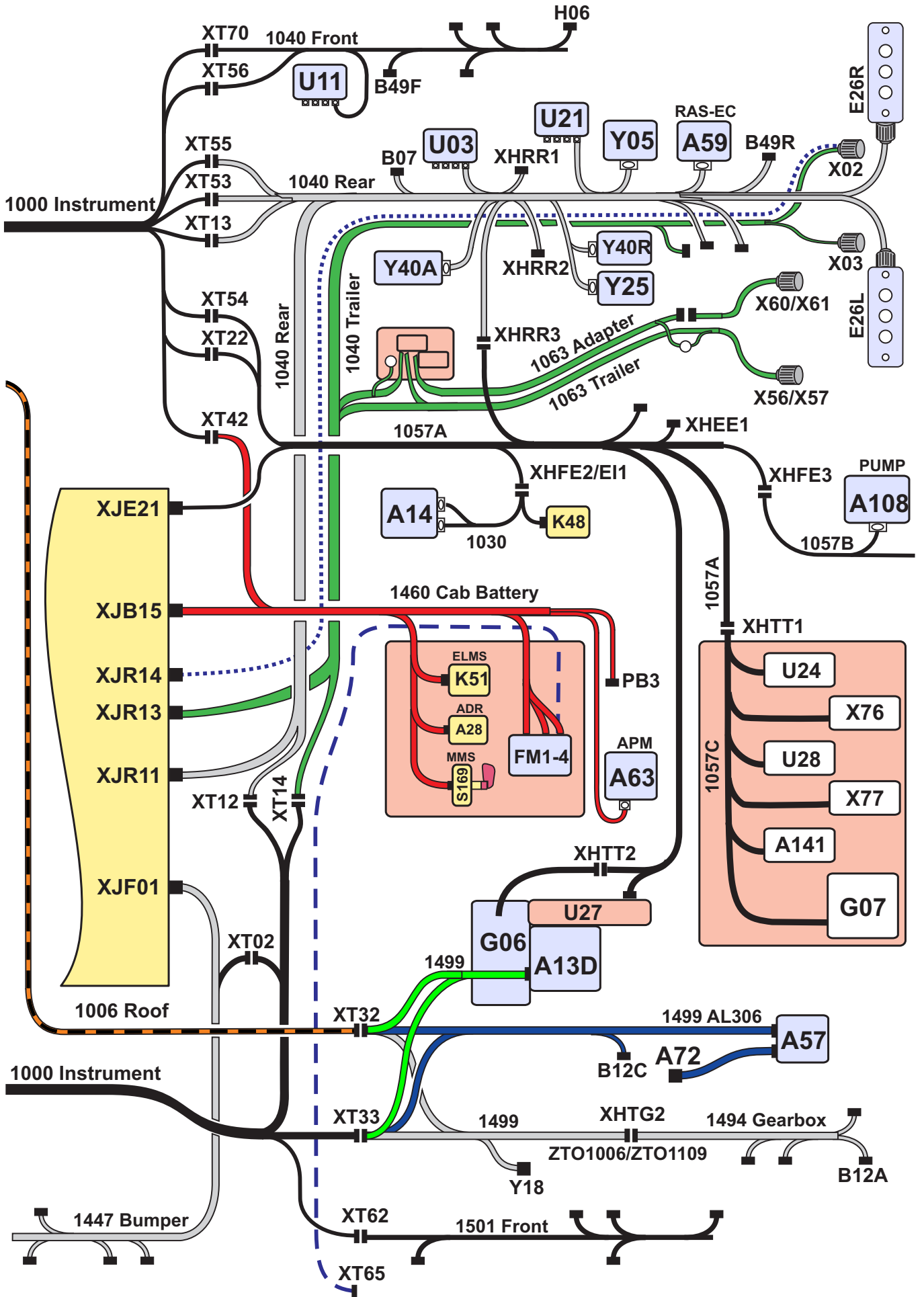

Ground connections

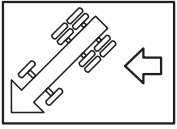

Ground

Ground

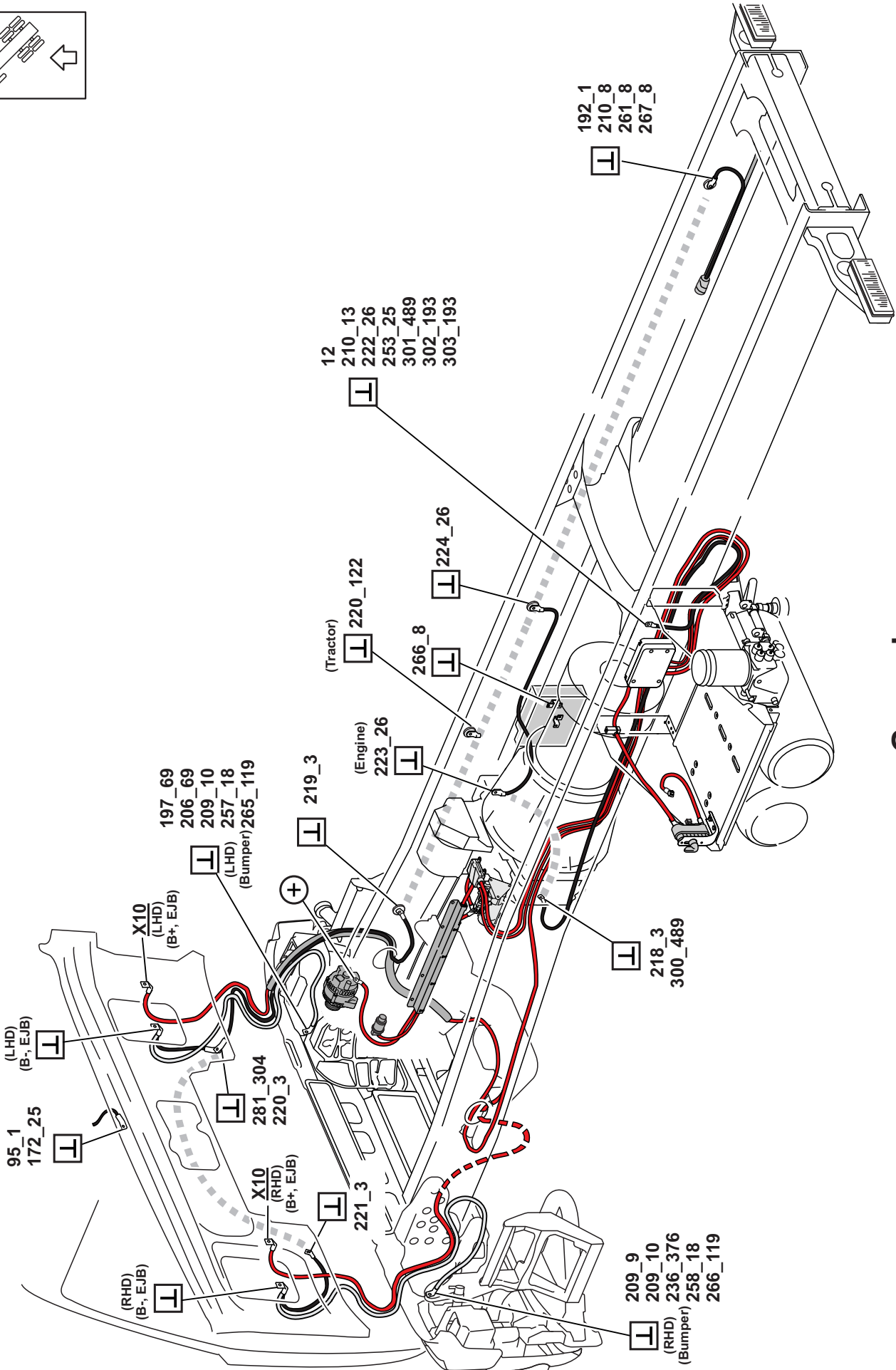

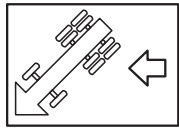

Ground, Hybrid

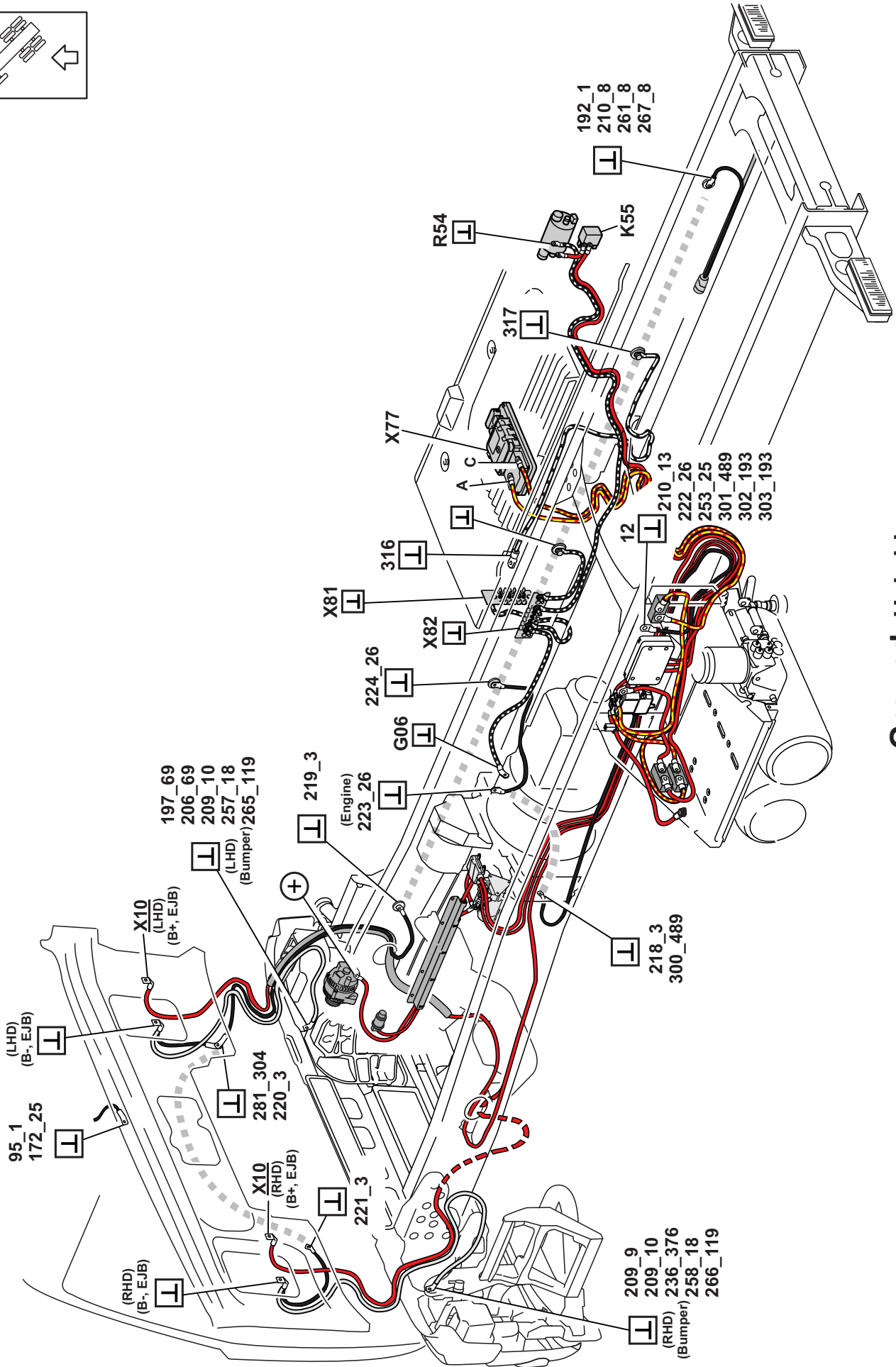

Ground, Hybrid

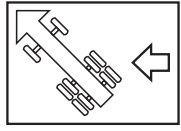

Ground, Hybrid-box

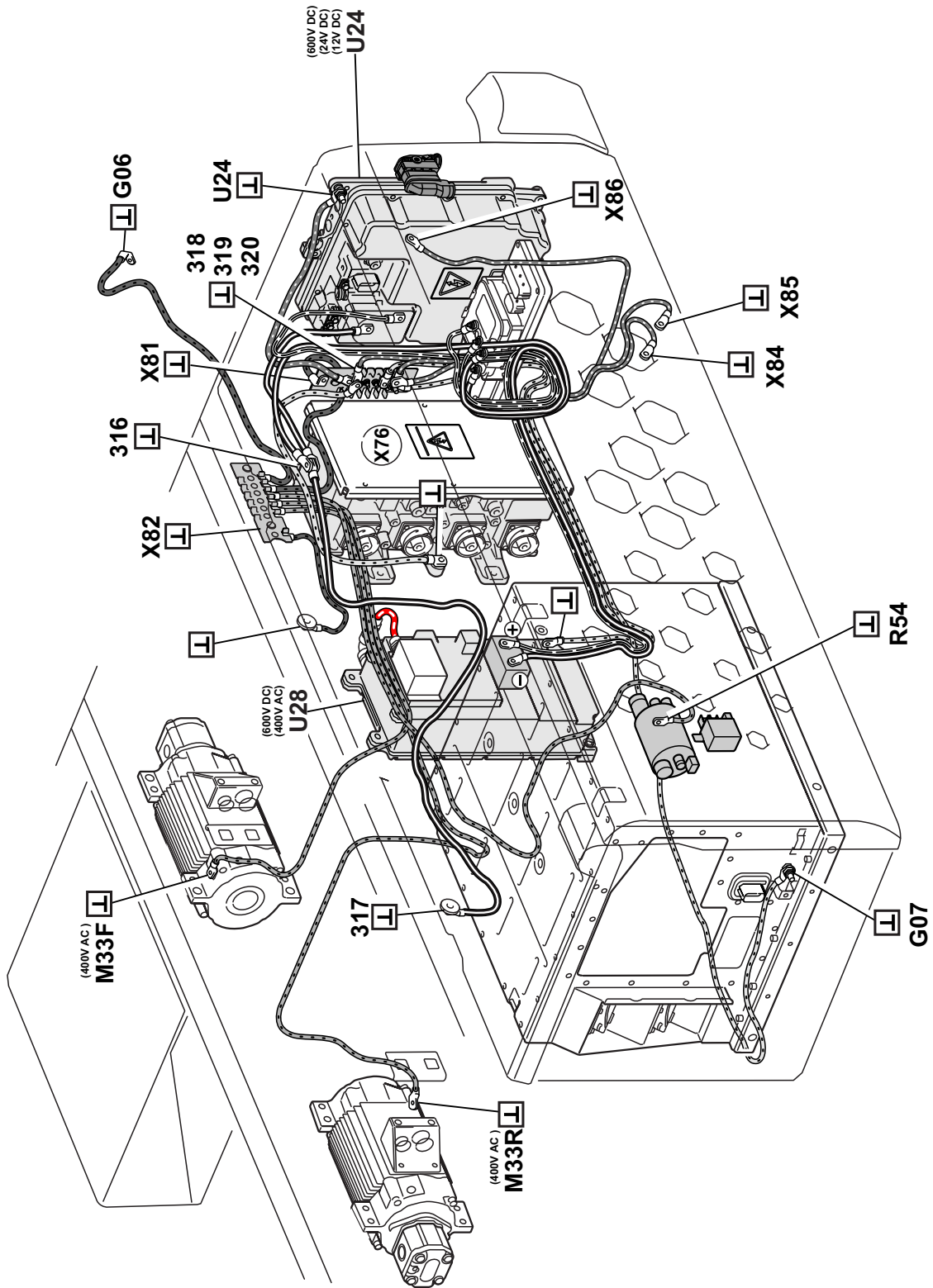

Ground, Hybrid-box

List of ground connections

12	(AA:0 E) (battery box)	192_1	(GC3:1 E) (right side end of frame)	209_9	(GC5:2 D) (bumper RHD)
21_1	(AB:3 D) (EJB)				
21_1	(AJ:0 B) (EJB)	192_1	(GC3:3 E) (right side end of frame)	209_9	(GC5:4 D) (bumper RHD)
23_1	(BM:2 C) (EJB)				
25_1	(BA:1 D) (EJB)	192_1	(GF:0 C) (right side end of frame)	209_9	(GM:1 E) (bumper RHD)
26_1	(BA:2 C) (EJB)	192_1	(GF:4 D) (right side end of frame)	209_9	(KA:2 D) (bumper RHD)
32_1	(BA:3 C) (EJB)				
39_1	(AG:2 B) (EJB)	192_1	(GK:0 C) (right side end of frame)	209_10	(GC2:1 D) (bumper LHD)
40_1	(AG:0 B) (EJB)				
41_1	(AH:0 B) (EJB)	192_1	(GK:1 C) (right side end of frame)	209_10	(GC2:1 E) (bumper RHD)
42_1	(AB_Hyb:0 B) (EJB)	192_1	(GK:4 A) (right side end of frame)	209_10	(GC2:2 D) (bumper LHD)
42_1	(AI:0 B) (EJB)				
59_1	(AB:1 B) (EJB)	194_25	(BA:0 E) (EJB)	209_10	(GC2:2 E) (bumper RHD)
64_1	(GM:2 E) (EJB)	196_1	(EM1:3 B) (EJB)		
81_1	(GA1:2 C) (EJB)	196_6	(GH1:0 E) (EJB)	209_10	(GM:1 E) (bumper LHD)
82_1	(GA2:1 B) (EJB)	196_10	(CU20:1 E) (EJB)	209_10	(GQ1:3 D) (bumper LHD)
84_1	(GB1:3 C) (EJB)	197_69	(GC2:2 D) (bumper LHD)	209_10	(GQ1:4 D) (bumper LHD)
85_1	(GB2:0 C) (EJB)				
86_1	(GB2:2 C) (EJB)	197_69	(GC5:2 D) (bumper LHD)	210_1	(KA:1 D) (EJB)
87_1	(IA:3 D) (EJB)				
95_1	(IF1:4 D) (cab front under windscreen)	197_69	(GC5:4 D) (bumper LHD)	210_8	(FA:0 A) (right side end of frame)
96_1	(IF1:4 E) (EJB)	197_69	(GM:1 E) (bumper LHD)	210_8	(FA2:1 A) (right side end of frame)
122_1	(GA1:4 C) (EJB)	197_69	(KA:1 D) (bumper LHD)	210_8	(GC3:1 E) (right side end of frame)
126_1	(GC2:3 E) (EJB)				
128_1	(GA2:4 D) (EJB)	198_1	(DN:0 A) (EJB)	210_8	(GC3:3 E) (right side end of frame)
136_1	(GQ:0 B) (EJB)	198_10	(CU21:3 D) (engine anchorage bracket, rear, right side)	210_13	(AA:1 E) (battery box)
137_1	(GQ:3 C) (EJB)				
143_1	(EM2:3 E) (EJB)				
144_1	(GD:2 E) (EJB)	199_69	(HJ1:3 E) (EJB)	210_13	(AC:1 E) (battery box)
147_1	(GD:0 E) (EJB)	203_5	(DU:3 B) (EJB)	210_13	(NC:1 B) (battery box)
149_1	(IR:1 B) (EJB)	203_25	(DU:3 C) (EJB)	211_3	(NA:1 B) (EJB)
151_1	(IN:3 E) (EJB)	206_4	(IR:4 B) (EJB)	211_6	(DQ1:1 C) (EJB)
156_1	(IM:3 E) (EJB)	206_69	(GC2:0 D) (bumper LHD)	212_6	(DQ1:1 B) (EJB)
157_1	(IM:4 E) (EJB)				
161_1	(GD:3 C) (EJB)	206_69	(GC5:0 D) (bumper LHD)	212_27	(FO:1 D) (EJB)
163_1	(IR:4 E) (EJB)	206_69	(GC5:1 D) (bumper LHD)	213_5	(HJ:3 E) (EJB)
165_1	(IR:0 B) (EJB)				
171_25	(DN:4 C) (EJB)	206_69	(GC5:3 D) (bumper LHD)	213_70	(GC2:3 C) (EJB)
172_25	(IF1:4 B) (cab front under windscreen)	206_69	(GC5:1 D) (bumper LHD)	213_76	(GC2:1 C) (EJB)
176_1	(IA:2 E) (EJB)				
183_1	(NB:4 C) (EJB)	206_69	(GC5:3 D) (bumper LHD)	216_6	(FC1:2 E) (EJB)
184_25	(HY:2 C) (EJB)	206_69	(GM:0 E) (bumper LHD)	217_25	(FA:3 D) (EJB)
187_1	(GH1:4 C) (EJB)				
191_3	(IR:0 D) (EJB)	207_23	(GQ1:3 D) (bumper LHD)	217_85	(DU:3 D) (EJB)
192_1	(FO:4 D) (right side end of frame)	209_9	(GQ1:4 D) (bumper LHD)	218_3	(AA:1 E) (engine ground)
			(FC:1 E) (EJB)	218_69	(ND:1 B) (EJB)
			(GC2:2 E) (bumper RHD)	218_95	(CU23:0 B) (EJB)
				219_3	(AA:2 E) (frame ground)
				219_69	(NA:4 B) (EJB)
				220_3	(AA:2 E) (cab ground)

220_62	(GH1:3 D) (EJB)	236_376	(GC2:0 E) (bumper RHD)	267_8	(GK:4 E) (right side end of frame)
220_122	(GF:1 D) (right frame)				
220_122	(GF:2 D) (right frame)	236_376	(GC5:0 D) (bumper RHD)	269_25	(AB:3 D) (EJB)
220_122	(GH1:4 D) (right frame)	236_376	(GC5:1 D) (bumper RHD)	271_25	(IU:2 B) (EJB)
220_122	(GK1:0 E) (right frame)	236_376	(GC5:3 D) (bumper RHD)	281_304	(AA:3 E) (cab front)
220_122	(GK1:1 E) (right frame)	236_376	(GM:0 E) (bumper RHD)	291_542	(IR1:2 B) (EJB)
220_122	(GK1:2 C) (right frame)	236_376	(GQ1:3 D) (bumper RHD)	300_489	(AA:1 E) (engine ground)
220_122	(GK1:3 A) (right frame)	236_376	(GQ1:4 D) (bumper RHD)	301_489	(AA:1 E) (battery box)
220_122	(GK1:4 E) (right frame)	238_6	(GH5:3 D) (EJB)	302_193	(AC:1 E) (battery box)
221_3	(AA:3 E) (cab to EJB RHD)	240_356	(CU22:4 E)	303_193	(AC:1 E) (battery box)
221_39	(IM:2 C) (EJB)	242_6	(DQ1:0 E) (EJB)	314_1174	(JB1_Hyb:0 D)
222_26	(AA:1 E) (battery box)	243_25	(EM2:3 B) (EJB)	314_1558	(JB5_Hyb:3 C)
222_6	(NB:0 B) (EJB)	247_6	(GM:3 C) (EJB)	316_1558	(JB1_Hyb:0 E) (Hybrid box)
223_25	(GQ:0 B) (EJB)	248_6	(GC4:3 E) (EJB)	317_1558	(JB1_Hyb:0 E) (Hybrid box)
223_26	(AA:2 E) (engine right side)	250_6	(GC5:1 A) (EJB)	317_2487	(CU52_Hyb:3 D) (Hybrid box)
224_26	(AA:2 E) (frame)	253_25	(AC:0 D) (battery box)	318_2487	(CU52_Hyb:1 D) (Hybrid box)
225_69	(ND:3 B) (EJB)	257_18	(GC2:1 D) (bumper LHD)	319_2487	(CU52_Hyb:1 D) (Hybrid box)
226_6	(GM:0 D) (EJB)	257_25	(AE:1 E) (EJB)	320_2487	(CU53_Hyb:4 D) (Hybrid box)
227_4	(GQ1:1 C) (EJB)	258_18	(GC2:1 E) (bumper RHD)		
227_13	(GH5:0 E) (EJB)	258_25	(AE:2 D) (EJB)		
227_25	(AE:2 D) (EJB)	261_8	(GC3:4 E) (right side end of frame)		
228_4	(BK:4 C) (EJB)	265_25	(KA:3 D) (EJB)		
228_25	(BT:0 B) (EJB)	265_119	(GC2:1 D) (bumper LHD)		
229_6	(GH3:2 E) (EJB)				
231_4	(BK:2 E) (EJB)	266_8	(GK:2 C) (right frame)		
234_8	(BM:3 C) (EJB)	266_119	(GC2:1 E) (bumper RHD)		
235_25	(IU:3 D) (EJB)				

List of connectors

E11

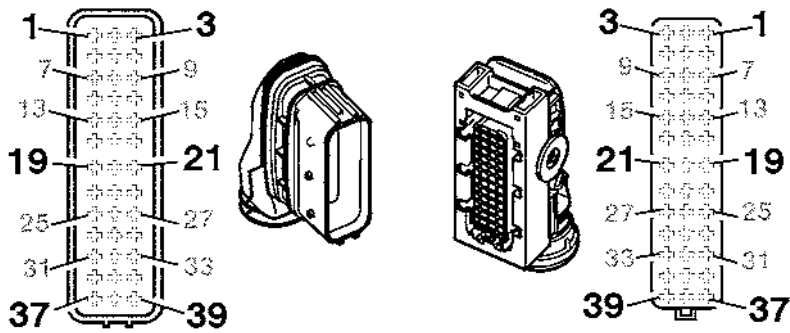

T3019924

Pin no:	Circuit function	Wiring no:	Diagram
1	J1939 CAN-1 Bus high	0012	CU20:1 B
2	Bus J1587-1 Diagnostic Line (A+)	0010	CU21:0 B
3	Can ODB (+)	0462	XD:2 B
4	J1939 CAN-1 Bus Low	0013	CU20:1 B
5	Bus J1587-1 Diagnostic Line (B-)	0011	CU21:0 B
6	Can ODB (-)	0463	XD:3 B
7	Power supply after relay K2	2323	CU22:1 C
8	Idle validation switch	5072	CU20:1 B
9	Alternator engine running, generating current	25	AB:1 C
10	Ground when main switch open	2226	AB:1 E
11	Engine speed "W" alternator termination	7	AB:0 D
13	Power supply kl. 15	291	CU20:0 B
15	Power supply kl. 15	291	CU20:1 B
18	Engine water level	81	CU20:1 D
20	Engine water level signal	0151	CU20:2 D
21	Power supply kl. 15	292	CU20:0 C
23	Climate compressor power supply	462	HY:4 D
27	Ground	1	CU22:4 E
28	Engine coolant level	82	CU20:1 D
31	Ground	1	CU20:1 D
35	Power supply starter relay	5101	CU22:0 C
37	Power supply kl. 30	808	CU22:3 C
39	Ground	1	CU20:1 D

PB3

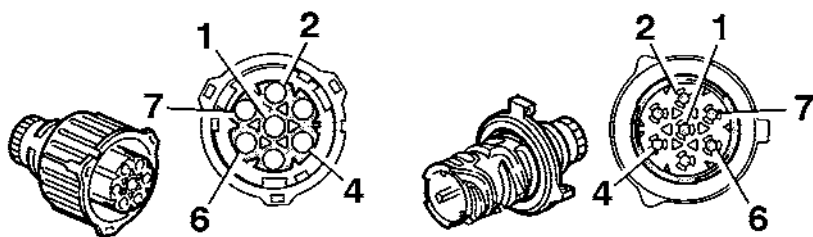

T3020295

Pin no:	Circuit function	Wiring no:	Diagram
1	Coded line alarm trailer connection freight	0403	NC:2 C
2	Power supply kl. 30	208	NC:2 C
3	Rear left marker	632	NC:2 C
4	Ground	1	NC:1 C
5	Rear right marker	634	NC:2 C
6	Power supply kl. 15	275	NC:2 C
7	Ground	1	NC:2 C

X02T

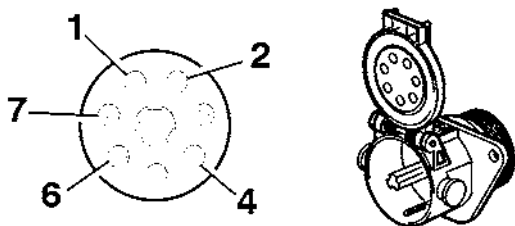

T3019932

Pin no:	Circuit function	Wiring no:	Diagram
1	Power supply kl. 30	522	GF:1 C
2	Power supply kl. 15	211	GF:1 C
3	Ground	1	GF:1 C
4	Ground	1	GF:1 C
5	ABS trailer state	352	GF:1 C
6	Trailer CAN bus: H line	0045	GF:1 C
7	Trailer CAN bus: L line	0046	GF:1 C

X03T

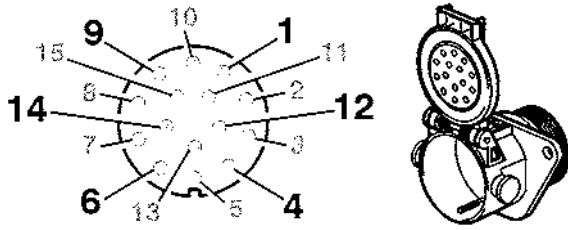

T3019933

Pin no:	Circuit function	Wiring no:	Diagram
1	Trailer turn left indicator	39	GF:3 C
2	Trailer turn right indicator	30	GF:3 C
3	Rear fog lights power supply	307	GF:3 C
4	Ground	1	GF:3 C
5	Rear left marker	632	GF:2 C
6	Rear right marker	634	GF:2 C
7	Brake lights power supply	3	GF:2 C
8	Reverse lights ON-OFF, and power supply	608	GF:2 C
9	Power supply kl.15	606	GF:2 C
13	Coded line alarm trailer connection freight	0403	GF:2 C
14	Chassis lighting or valve lighting	618	GF:2 C

XACC11 (PB1)

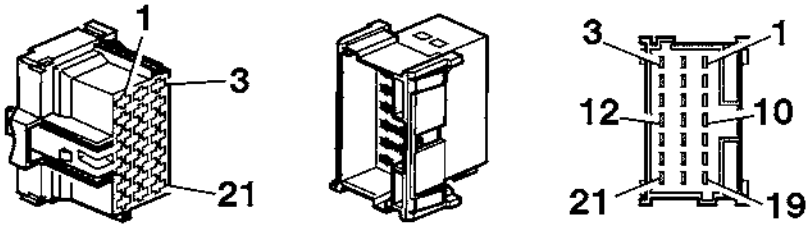

T3019799

Pin no:	Circuit function	Wiring no:	Diagram
1	Ground	1	NA:4 C
2	Power supply kl. 15	2234	NA:3 C
3	Power supply (alternator information, engine running)	4306	NA:3 C
4	PTO 1 request on chassis	1140	NA:2 C
5	Reverse lights ON-OFF, and power supply	608	NA:0 C
6	Parking brake engaged	8118	NA:3 C
7	PTO 1 ON information	8169	NA:0 C
8	Engine speed control request from chassis	8067	NA:2 C
9	Engine speed "W" alternator termination	7	NA:4 C
10	PTO 1 valve	8093	NA:4 C
11	Switch engine speed 1	1026	NA:1 C
12	Neutral gear box information	12	NA:3 C
13	Engine speed control decrease	8119	NA:2 C
14	Switch engine speed 2	1141	NA:1 C
15	Tachograph speed puls to fleet management	5108	NA:4 C
16	Engine speed control increase	8120	NA:2 C
17	Engine stop request from chassis	8110	NA:4 C
18	Vehicle speed trigger output	1025	NA:0 C
19	Return to normal speed	8121	NA:2 C
20	Power supply kl. 30	208	NA:1 C
21	Ground	1	NA:1 C

XACC12 (PB2)

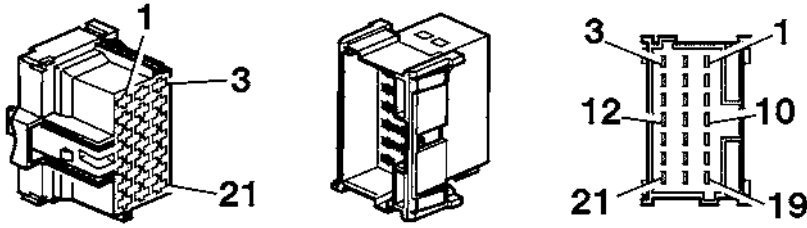

T3019799

Pin no:	Circuit function	Wiring no:	Diagram
3	Chassis/equipment	8116	NB:2 C
4	Bodybuilder predisposition switch	0460	NB:0 C
5	RSL 2 (speed limit)	8020	NB:1 C
6	Machine on	8083	NB:3 C
7	Bodybuilder predisposition switch	0461	NB:0 C
8	Emergency switch	5074	NB:1 C
9	Chassis lighting or valve lighting	618	NB:3 C
11	RSL 3 (speed limit)	8095	NB:1 C
12	Machine working position	651	NB:2 C
14	Inhibit vehicle immobilization	8227	NB:2 C
16	Air suspension inhibit regulation	8137	NB:0 C
17	Body builder level chassis control	8138	NB:0 C
18	Auxiliary pump feedback	89	NB:2 C

XACC13 (PB4)

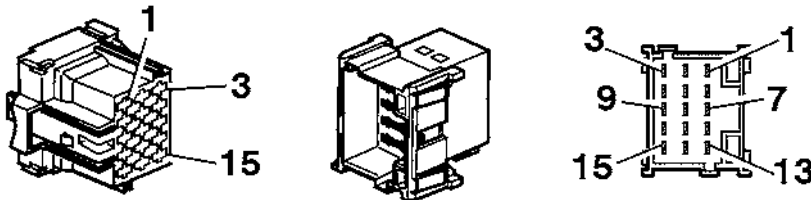

T3019800

Pin no:	Circuit function	Wiring no:	Diagram
1	Bus J1587-1 Diagnostic Line (B-)	0011	ND:1 C
2	Power supply after relay K2	2125	ND:2 C
4	Bus J1587-1 Diagnostic Line (A+)	0010	ND:1 C
5	PTO 2 request	8113	ND:2 C
6	PTO 3 request	8112	ND:3 C
7	Ground	1	ND:1 C
8	PTO 2 feedback	8134	ND:2 C
9	PTO 3 feedback	158	ND:3 C
10	J1939 CAN-1 Bus high	0012	ND:1 C
11	PTO 2 valve control	8161	ND:2 C
12	PTO 3 valve	8115	ND:4 C
13	J1939 CAN-1 Bus Low	0013	ND:1 C
14	Ground	1	ND:3 C

XACC15 (PB5)

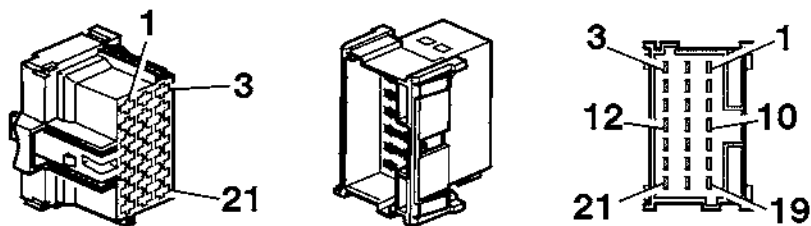

T3019799

Pin no:	Circuit function	Wiring no:	Diagram
1	PTO 3 request	8112	NE:3 C
2	PTO 2 request	8113	NE:2 C
3	Engine start	8100	NE:0 C
4	PTO 3 feedback	158	NE:3 C
5	PTO 2 feedback	8134	NE:2 C
6	Engine start allowed	8108	NE:0 C
7	PTO 3 valve	8115	NE:4 C
8	PTO 2 valve	8161	NE:3 C
9	Engine warning / faults or others function	8104	NE:0 C
10	PWM programmable output	8170	NE:2 C
11	Free output 1	8122	NE:1 C
12	Free output 2	8123	NE:1 C
14	Input free (-) for logical function	8132	NE:1 C
15	Input free (+) for logical function	8131	NE:1 C
16	Engine speed control PWM signal	0384	NE:3 C
17	Enable PWM input control	8136	NE:4 C
18	Enable CAN control	8133	NE:4 C
20	Can low for body builder	0413	NE:2 C
21	Can high for body builder	0414	NE:2 C

XACC17

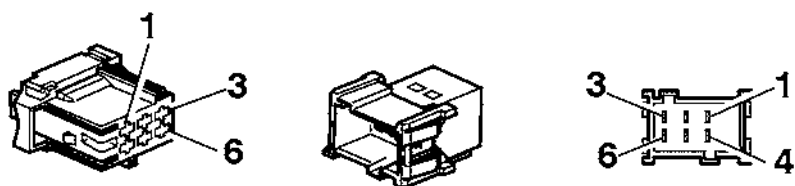

T3019918

Pin no:	Circuit function	Wiring no:	Diagram
2	Low range transfer box request	8124	IO:2 B
3	Low range transfer box control	8125	IO:1 B

XACD61

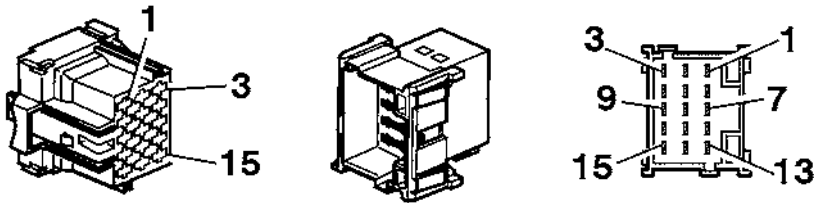

T3019800

Pin no:	Circuit function	Wiring no:	Diagram
1	Power supply kl. 30	45	GH1:2 B/GH5:2 B
2	Ground	1	IF1:3 E
3	Adjustable mirror motors control	432	IF1:2 D/IF2:2 B
4	Passenger window lift control	470	IQ:2 C
5	Heated mirror power supply. Windscreen heater relay control	4	IF1:2 C/IF2:2 C
6	Heated mirror request	386	IF1:0 C
8	Power supply kl. 15	215	IF1:0 B
9	Front door switch control/instep lights control	119/4322	GH1:2 C
11	Adjustable mirror motor control	428	IF1:2 C/IF2:2 C
12	Dashboard illumination power supply	64	IF1:1 B
13	Power supply kl. 15	2232	IQ:3 B
14	Adjustable mirror motor control	430	IF1:1 D/IF2:2 C
15	Passenger window lift control	469	IQ:2 C

XACD62

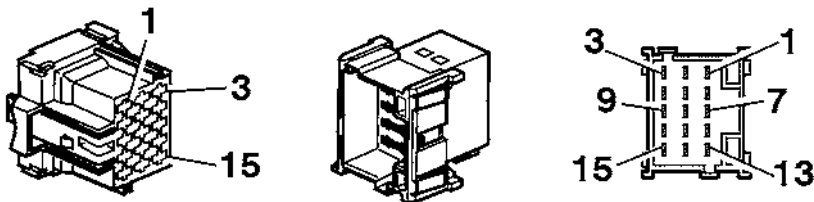

T3019800

Pin no:	Circuit function	Wiring no:	Diagram
1	Power supply kl. 30	45	GH1:2 B/GH5:2 B
2	Ground	1	IF1:4 C
3	Adjustable mirror motors control	432	IF1:2 D/IF2:2 B
4	Passenger window lift control	470	IQ:2 C
5	Heated mirror power supply. Windscreen heater relay control	4	IF1:2 D/IF2:2 B
7	Outside temperature sensor (-)	710	BK:0 D
8	Outside temperature sensor (+)	709	BK:1 D
9	Front door switch control/instep lights control	119/4322	GH1:2 C/GH5:2 C
11	Adjustable mirror motor control	428	IF1:2 D/IF2:2 C
12	Dashboard illumination power supply	64	IF1:1 B
14	Adjustable mirror motor control	430	IF1:2 E/IF2:2 C
15	Passenger window lift control	469	IQ:2 C

XACH01

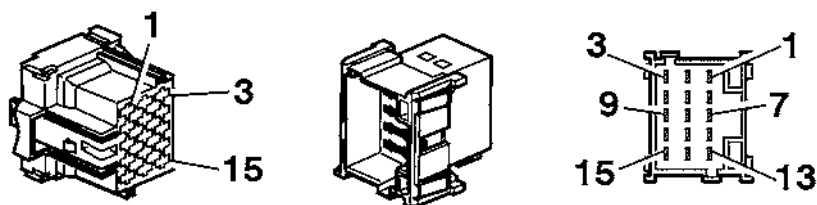

T3019800

Pin no:	Circuit function	Wiring no:	Diagram
1	Tachograph speed pulse	59	BM:3 C
2	Radio left loudspeaker (-)	444	IU:2 C/IU1:2 B
3	Radio left loudspeaker (+)	451	IU:2 B/IU:2 B
4	BUS J1939 CAN 2 (+)	0411	XC:0 C
5	Radio right loudspeaker (+)	447	IU:3 B/IU1:3 B
6	BUS J1939 CAN 2 (+)	0411	XC:0 C
7	BUS J1939 CAN 2 (-)	0412	XC:0 C
8	Radio right loudspeaker (-)	448	IU:3 B/IU1:3 B
9	BUS J1939 CAN 2 (-)	0412	XC:0 C
10	Tachograph speed pulse to fleet management	5108	BM:3 C
11	Indicator signal to LCM	0375	IM:2 B
12	Door sensor signal	1159	IM:1 C
13	Tachograph serial data to fleet management	0405	BM:4 C
14	Tachograph speed pulse to fleet management	5108	BM:3 C

XACH02

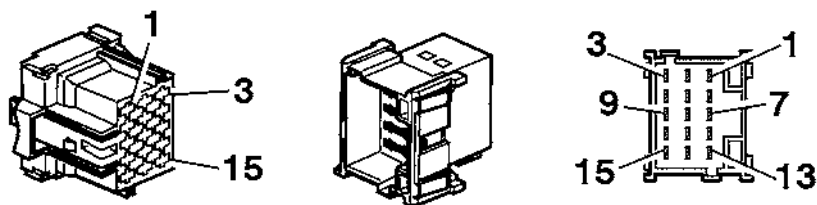

T3019800

Pin no:	Circuit function	Wiring no:	Diagram
1	CD data in	4323	IU:2 D
2	Micro ground	20	IU1:1 B
3	Micro power supply	11	IU1:1 B
4	CD data out	4324	IU:2 D
8	CDC on	4325	IU:2 D
9	Beacon warnings lamps control	322	GC2:3 B
10	CDC AF ground	4326	IU:3 D
11	CD AF-in left	4327	IU:3 D
12	Alarm siren power supply	2303	IN:3 C
13	CD AF-in right	4328	IN:3 C
15	Burglar alarm control	0039	IN:3 C

XACR13

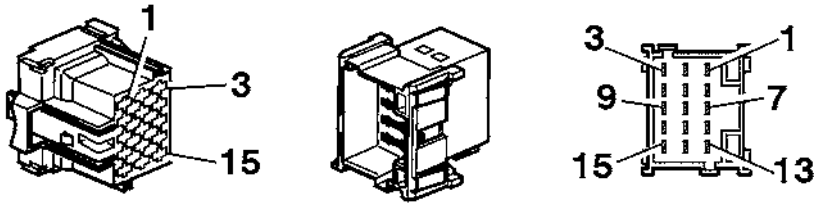

T3019800

Pin no:	Circuit function	Wiring no:	Diagram
6	Power supply kl. 15	2310	DQ1:3 A
7	Power supply kl. 30	2227	DQ1:4 A
8	Dashboard illumination power supply	64	DQ1:4 A
9	J1939 CAN-1 Bus high	0012	DQ1:3 A
10	J1939 CAN-1 Bus low	0013	DQ1:3 A
11	Dashboard illumination power supply	64	DQ1:4 B
12	Ground	1	DQ1:4 C

XACR14_H

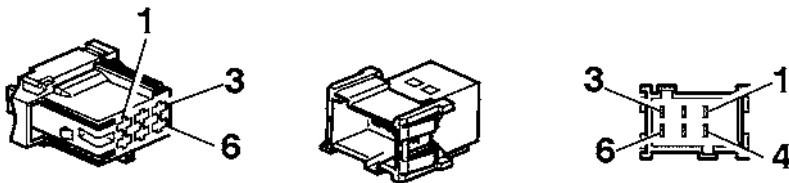

T3019918

Pin no:	Circuit function	Wiring no:	Diagram
1	Driveline active	233	AB_Hyb:4 C
2	Driveline active	233	AB_Hyb:4 C

XACR15

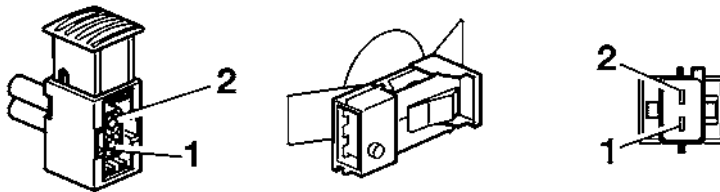

T3019920

Pin no:	Circuit function	Wiring no:	Diagram
1	Ground	1	IR:4 E
2	Power supply kl. 30	2302	IR:4 D

XADH01

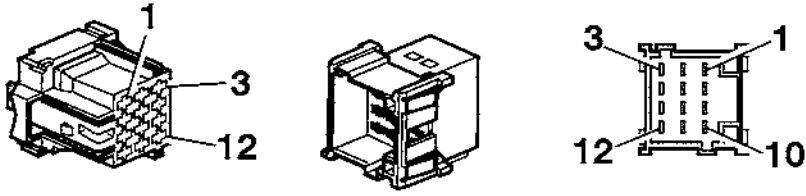

T3019801

Pin no:	Circuit function	Wiring no:	Diagram
1	Driver door lock/unlock motor control	4316	IM:1 D
5	Driver door lock/unlock motor control	4317	IM:1 D
9	Driver door unlock indication	4318	IM:1 D

XADH02

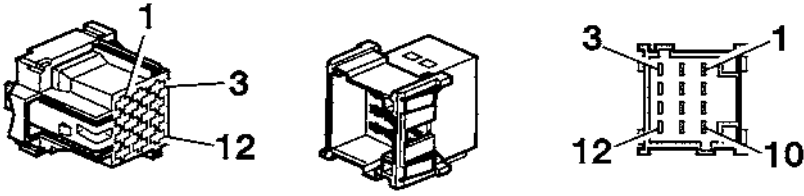

T3019801

Pin no:	Circuit function	Wiring no:	Diagram
1	Passenger door lock/unlock motor control	4313	IM:2 D
5	Passenger door lock/unlock motor control	4314	IM:2 D
9	Passenger door unlock indication	4315	IM:1 D

XAHH1

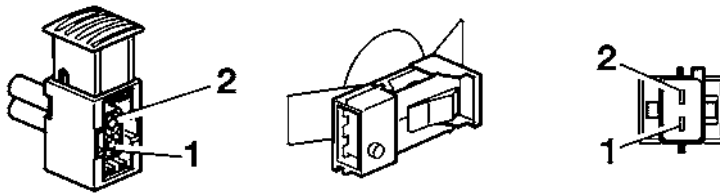

T3019920

Pin no:	Circuit function	Wiring no:	Diagram
1	Ground	1	GC2:3 E
2	Beacon warnings lamps power supply	323	GC2:3 D

XAHH2

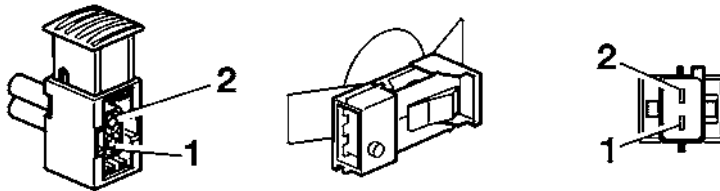

T3019920

Pin no:	Circuit function	Wiring no:	Diagram
1	Ground	1	GC2:4 E
2	Beacon warnings lamps power supply	323	GC2:4 C

XAHR1

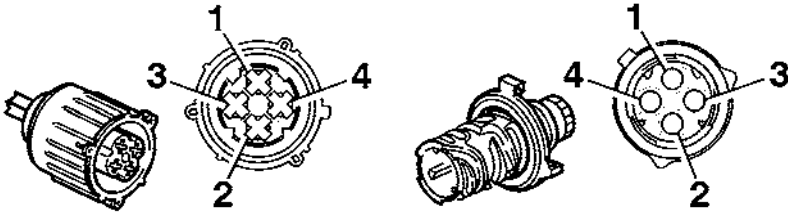

T3019922

Pin no:	Circuit function	Wiring no:	Diagram
1	Beacon warnings lamps power supply	323	GC2:3 D
2	Beacon warnings lamps power supply	323	GC2:3 D
3	Ground	1	GC2:3 E
4	Ground	1	GC2:3 D

XAHR3

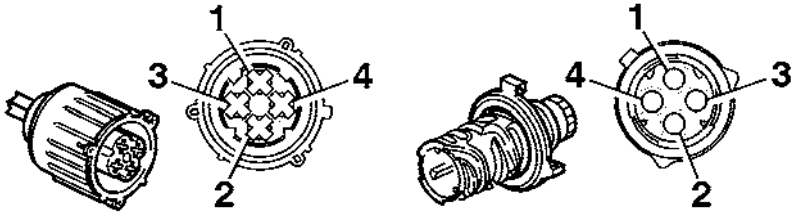

T3019922

Pin no:	Circuit function	Wiring no:	Diagram
1	Beacon warnings lamps power supply	323	GC2:3 D
2	Ground	1	GC2:3 E

XAHR4

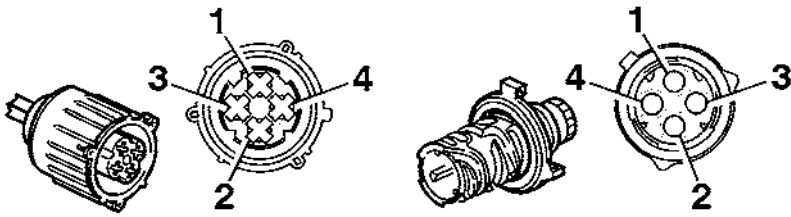

T3019922

Pin no:	Circuit function	Wiring no:	Diagram
1	Beacon warnings lamps power supply	323	GC2:4 D
2	Ground	1	GC2:4 D

XHEE1

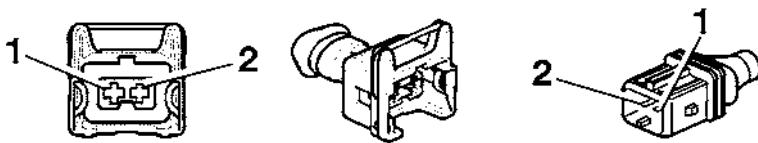

T3019926

Pin no:	Circuit function	Wiring no:	Diagram
1	Engine water level signal	0151	CU20:1 D
2	Engine water level	81	CU20:1 D

XHFE3

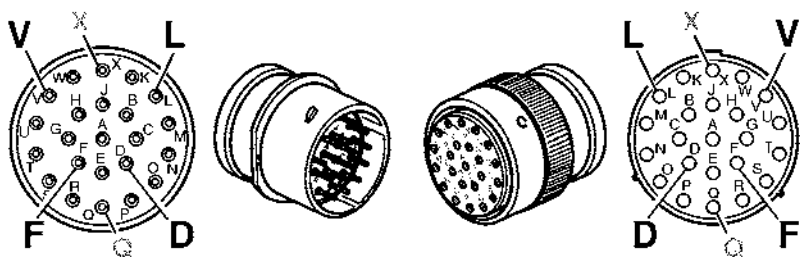

T3020191

Pin no:	Circuit function	Wiring no:	Diagram
A	Bus J1587-1 Diagnostic Line (A+)	0010	CU23:3 D
B	Bus J1587-1 Diagnostic Line (B-)	0011	CU23:3 D
C	Engine water level	81	CU20:2 E
D	Engine water level signal	0151	CU20:2 D
E	Ground	1	CU23:0 C
F	Power supply after relay K2	2329	CU23:3 C
G	CAN ODB (+)	0462	XD:1 C
H	CAN ODB (-)	0463	XD:1 C
K	Power supply after relay K2	2329	CU23:4 A
L	CAN ODB (+)	0462	XD:2 C
M	CAN ODB (-)	0463	XD:3 C
N	Direct battery	2328	CU23:2 C
O	Direct battery	2328	CU23:2 C
P	Ground	1	CU23:4 A
Q	EBS trailer control module pressure sensor supply	0376	EM2:1 D
R	EBS trailer control module pressure sensor signal	0377	EM2:1 D
S	EBS trailer control module pressure sensor ground	0380	EM2:2 D
T	EBS trailer control module power supply	5050	EM2:2 D
U	EBS TMC inlet valve control	5091	EM2:2 D
V	EBS TMC outlet valve control	5092	EM2:2 D
W	EBS TMC backup valve control	5093	EM2:3 D
X	Ground	1	CU23:0 C

XHRR1

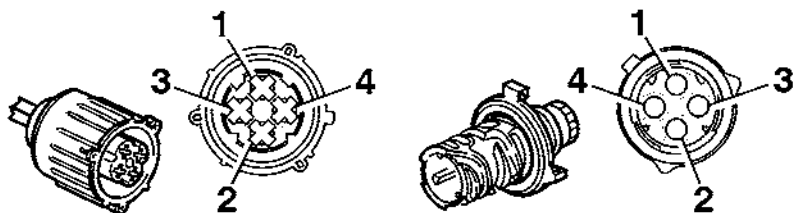

T3019922

Pin no:	Circuit function	Wiring no:	Diagram
1	Ground	1	GC4:0 C
2	Parking lights right side	304	GC4:0 A

XHRR2

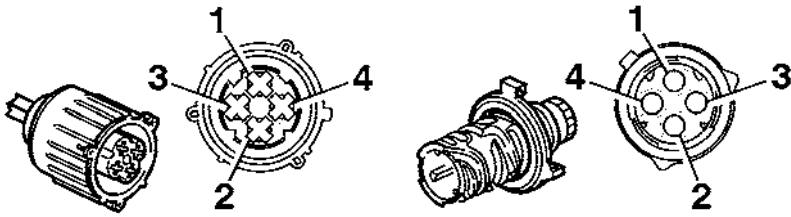

T3019922

Pin no:	Circuit function	Wiring no:	Diagram
1	Ground	1	GC4:1 D
2	Parking lights left side	305	GC4:1 A

XHRR3

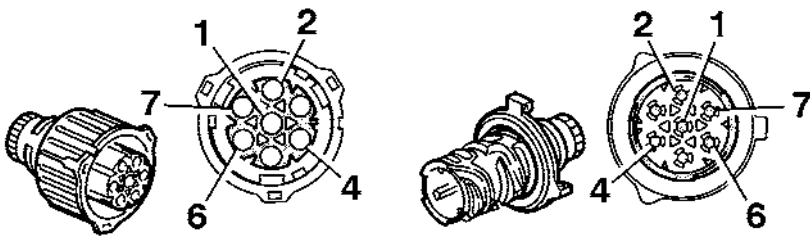

T3020295

Pin no:	Circuit function	Wiring no:	Diagram
1	Bus J1587-1 Diagnostic Line (A+)	0010	FO:1 D
2	Bus J1587-1 Diagnostic Line (B-)	0011	FO:1 D
3	J1939 CAN-1 Bus high	0012	FO:2 A
4	J1939 CAN-1 Bus low	0013	FO:3 A
5	J1939 CAN-1 Bus high	0012	FO:3 A
6	J1939 CAN-1 Bus low	0013	FO:3 A

XHTG1

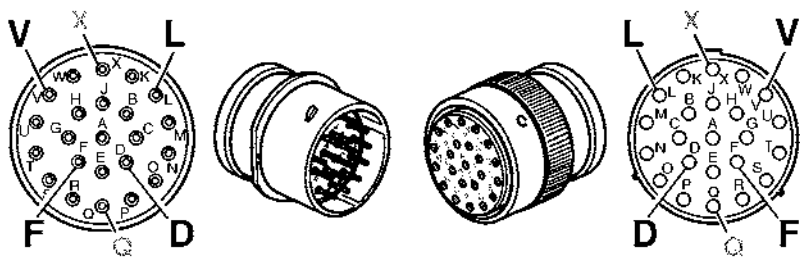

T3020191

Pin no:	Circuit function	Wiring no:	Diagram
A	Manual gearbox reverse gear switch	661	GD:0 B
B	Tachograph speed sensor supply	142	BM:3 D
C	Speed signal real time	141	BM:3 D
D	Ground	825	BM:3 D
E	Tachograph data signal	0056	BM:3 D
F	Neutral gearbox information	12	BA:3 B
H	PTO 1 feedback speed 1	88	DQ:1 C
L	PTO 2 feedback	8134	DQ:3 C
S	Ground	1	GD:0 D

XHTG2

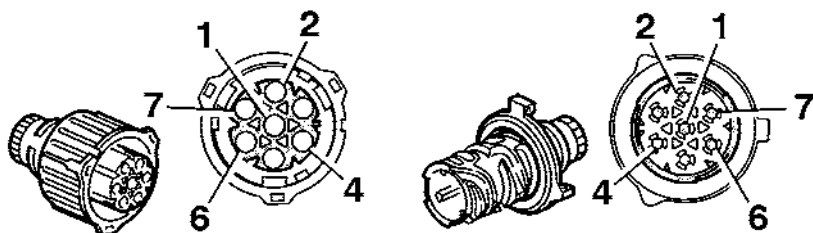

T3020295

Pin no:	Circuit function	Wiring no:	Diagram
1	Tachograph speed sensor supply	142	BM:2 D
2	Speed signal real time	141	BM:2 D
3	Ground	825	BM:2 D
4	Tachograph data signal	0056	BM:2 D
5	PTO 1 feedback speed 1	88	DQ:1 C
6	Ground	1	GD:0 D

XHTT1

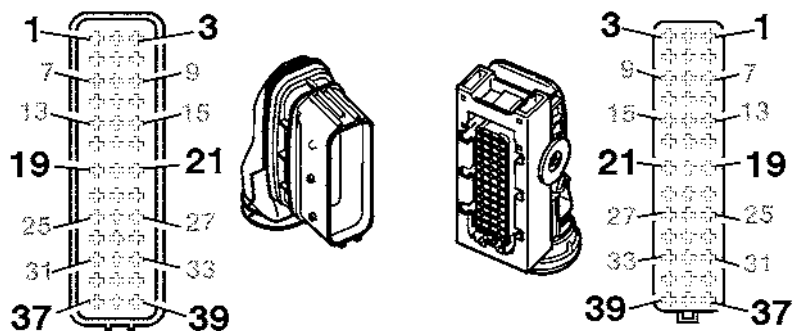

T3019924

Pin no:	Circuit function	Wiring no:	Diagram
1	Can ODB (+)	0462	JB3_Hyb:2 B
2	Can ODB (-)	0463	JB3_Hyb:2 B
4	Bus J1587-1 Diagnostic Line (A+)	0010	JB3_Hyb:2 A
5	Bus J1587-1 Diagnostic Line (B-)	0011	JB3_Hyb:2 A
6	HVIL in	01	JB3_Hyb:2 D
7	HVIL out	02	JB3_Hyb:2 D
8	Power supply kl. 15	2121	JB3_Hyb:2 A
9	Main PEC	237	JB3_Hyb:2 C
10	Ignition PEC	239	JB3_Hyb:2 D
11	CAN hybrid H	0049	JB3_Hyb:2 C
12	CAN hybrid L	0048	JB3_Hyb:2 C
13	Ground (PEC)	107	JB3_Hyb:2 D
18	Temperature sensor (PTC2)	714	JB4_Hyb:2 B
19	Temperature sensor (PTC1)	713	JB4_Hyb:2 B
24	Temperature sensor (PTC2)	716	JB4_Hyb:2 D
25	Temperature sensor (PTC1)	715	JB4_Hyb:2 D
29	Sensor cooling level MDS (ground)	108	JB3_Hyb:2 E
30	Cooling level MDS sensor	77	JB3_Hyb:2 E
31	J1939-7 H	0462	JB3_Hyb:2 C
32	J1939-7 L	0463	JB3_Hyb:2 C
33	HVIL in	048	JB4_Hyb:2 C
34	HVIL out	049	JB4_Hyb:2 C
35	HVIL in	050	JB4_Hyb:2 E
36	HVIL out	051	JB4_Hyb:2 E

XHTT2

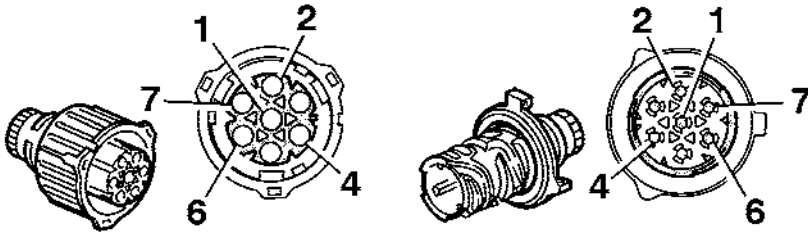

T3020295

Pin no:	Circuit function	Wiring no:	Diagram
1	Resolver EM-PEC (ground)	113	CU50_Hyb:2 C
2	Resolver EM-PEC (Sin 1)	089	CU50_Hyb:2 C
3	Resolver EM-PEC (Sin 2)	090	CU50_Hyb:2 C
4	Resolver EM-PEC (Ref 1)	091	CU50_Hyb:2 C
5	Resolver EM-PEC (Ref 2)	092	CU50_Hyb:2 D
6	Resolver EM-PEC (Cos 1)	093	CU50_Hyb:2 D
7	Resolver EM-PEC (Cos 2)	094	CU50_Hyb:2 D

XJB15

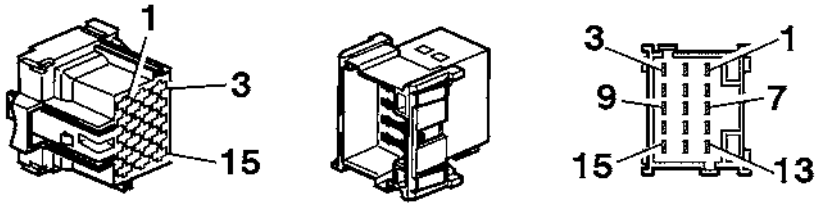

T3019800

Pin no:	Circuit function	Wiring no:	Diagram
1	Power supply kl. 30	2230	FC:1 B/FC1:1 B
2	Power supply kl. 30	208	NC:1 B
4	Power supply kl. 15	24	FC:2 E/FC1:2 D
5	Direct battery	203	BM:2 B
6	ADR main switch led ground	1149	AC:2 C
7	Power supply kl. 15	275	NC:1 B
8	Key inserted info	5066	AC:1 B
9	Main switch command	147	AA:2 C
10	Rear left marker	632	NC:1 B
11	Rear right marker	634	NC:1 B
12	Power supply kl. 30	2223	AA:0 B/AE:3 B
13	Bus J1587-1 diagnostic line (B-)	0011	XA:3 C
14	Bus J1587-1 diagnostic line (A+)	0010	XA:3 C
15	Coded line alarm trailer connection freight	0403	NC:2 B

XJC01_01

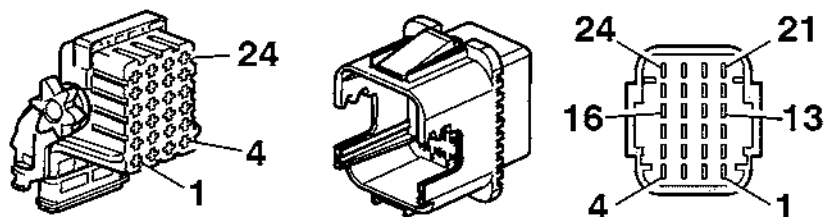

T3019802

Pin no:	Circuit function	Wiring no:	Diagram
1	Battery charging information	2307	BK:2 D
2	Power supply kl. 30	208	NA:1 B
3	PTO 1 ON information	8169	NA:0 B
4	Brake lights relay VECU control	5028	BA:1 D
5	Ground	1	GC2:3 C
6	Ground	1	ND:1 B
7	Power supply kl. 15	47	IR:0 C/IR12 B
7	Power supply kl. 15	4309	IR1:2 B
8	Power supply kl. 30	45	GH1:2 B/GH5:2 B
9	Front door switch control/instep lights control	119	GH1:0 C/GH5:1 C
10	Front door switch control/instep lights control	119	GH1:0 D/GH5:0 D
11	Power supply kl. 30	719	BK:3 B
12	ADR alternator relay	2126	AE:1 D
12	Power supply kl. 15	2317	AB_Hyb:0 C
13	Door switch signal	1159	GH1:0 C/GH5:1 C
14	Power supply kl. 15	24	IM:4 B
15	Accessories key position	214	AB:1 B/AE:1 B
16	Park brake trigger relay control	83	BA:0 B
17	Power supply kl. 15	24	AI:3 D
18	Power supply kl. 15	2125	ND:2 B
19	Power supply kl. 15	24	BK:0 B
20	Relay water heater control	49	AB_Hyb:0 D
20	ADR alternator relay control	1150	AE:1 D
21	Power supply kl. 30	2316	GQ:0 B
22	Power supply kl. 15	229	BA:1 B
23	Park brake trigger relay	8118	NA:3 B
24	Relay EMS control	0023	BA:1 B

XJC01_02

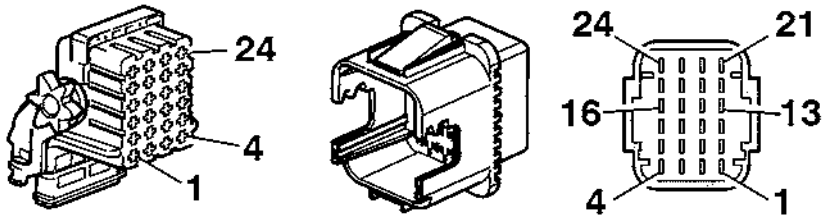

T3019802

Pin no:	Circuit function	Wiring no:	Diagram
1	Dashboard illumination power supply	64	NB:4 A
2	Dashboard illumination power supply	64	IO1_Hyb:0 A
3	Dashboard illumination power supply	64	GC5:1 A
5	Left front high beam lights power supply	603	BK:4 B
6	Dashboard illumination power supply	64	GQ:3 A
7	Ground	1	GM:0 D
8	Ground	1	GQ:0 B
9	Dashboard illumination power supply	64	DQ:4 A
10	Dashboard illumination power supply	64	IF1:1 B
11	Ground	1	ND:3 B
12	Ground	1	BK:4 C
13	Power supply kl. 30	310	GQ1:2 B
14	Ground	1	HY:2 C
15	Rear fog lights relay control	370	GB2:2 B
16	Ground	1	GQ:3 B
17	Rear fog lights power supply	307	BK:3 B
18	Wiper parking status	509	GQ:4 B
19	Wiper parking status	509	GM:2 D
20	Power supply kl. 15	501	GM:2 B
22	Intermittent wiper timer relay control	503	GQ:4 B
23	Low speed wiper motor power supply	507	GM:2 C
24	Power supply kl. 15	501	GM:2 B

XJC01_03

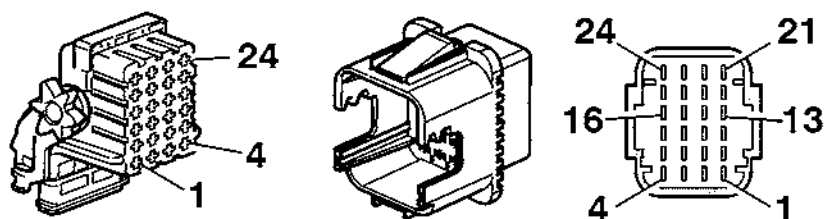

T3019802

Pin no:	Circuit function	Wiring no:	Diagram
1	Power supply kl. 15	2122	BA:1 B
3	Dashboard switch power supply from VECU	2123	BA:3 A
4	Bus J1587-1 diagnostic line (B-)	0011	XA:1 C
5	Ground	1	GM:3 B
6	Power supply kl. 15	2121	DQ:3 B
7	Dashboard switch power supply from VECU	2123	BA:2 A
8	Bus J1587-1 diagnostic line (A+)	0010	XA:1 C
9	Reverse lights relay control	1018	GD:1 A
10	Parking lights control by stalk switch	313	GQ:3 B
11	Dashboard switch power supply from VECU	2123	BA:2 A
12	ADR alternator relay control	2226	AB:2 D/AE:1 D
13	Parking lights control by stalk switch	313	GA1:2 B
14	Parking lights relay control	303	GQ:2 D
15	Power supply kl. 30	2227	AB:0 B/AE:0 B
16	Accessories power supply	4309	IU:1 B
17	Reverse lights ON-OFF, and power supply	608	NA:0 B
18	Power supply kl. 30	2227	DQ1:4 A
19	Power supply kl. 30	373	GA1:3 B
20	Power supply kl. 30	663	GB1:3 B
21	Power supply kl. 30	2120	NB:4 A
22	Power supply kl. 30	2227	IM:4 B
23	Power supply kl. 30	373	GQ:2 B
24	High beam lights relay control	62	GB1:3 B

XJC01_04

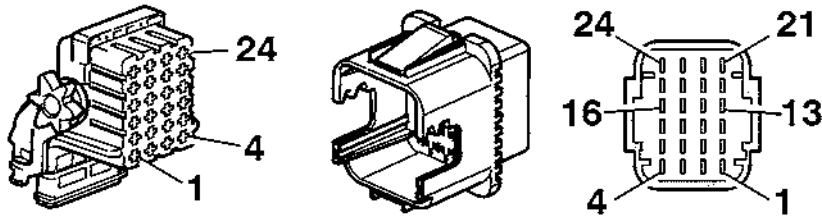

T3019802

Pin no:	Circuit function	Wiring no:	Diagram
1	Power supply kl. 30	263	IU:2 B
2	PTO 1 feedback (speed 1)	88	DQ:1 B
3	PTO 1 feedback (speed 1)	88	BA:4 B
4	Front door switch control/instep lights control	4321/119	GH1:1 C/GH5:1 C
5	Ground	1	FO:1 D
6	Ground	1	DQ:4 D
7	Bus J1587-1 diagnostic line (B-)	0011	XA:2 C
8	Bus J1587-1 diagnostic line (A+)	0010	XA:2 C
9	Power supply (alternator information, engine running)	4306	NA:3 B
10	Ground	1	DU:3 C
11	Ground	1	GQ:1 B
12	Ground	1	GH1:1 E/GH5:1 E
13	Power supply kl. 15	2310	AH:4 D
14	Ground	1	NA:4 B
15	Ground	1	NA:1 B
16	Power supply kl. 30	202	GQ:2 B
17	Power supply kl. 15	808	AJ:1 D
18	Ground	1	BK:2 E
20	Power supply kl. 30	202	GQ:2 B
21	Power supply kl. 15	22	AB:2 A/AE:1 B
22	Power supply kl. 15	463	HY:3 C
23	Power supply kl. 30	2306	BK:2 B
24	Power supply kl. 15	243	AH:3 D

XJC01_05

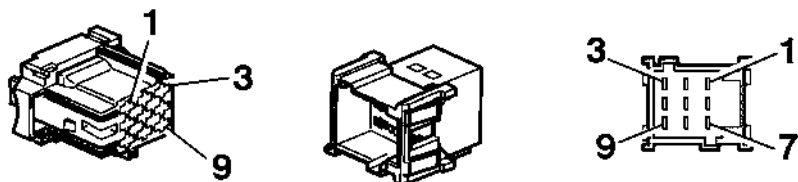

T3019929

Pin no:	Circuit function	Wiring no:	Diagram
1	Power supply kl. 30	663	GB1:3 A
2	Power supply kl. 30	2023	AB_Hyb:3 B
3	Power supply kl. 30	2233	FO:1 A
6	Ground	1	GM:2 E
7	Ground	1	BA:2 B
8	Ground	1	FO:1 D
9	Power supply kl. 15	274	FO:1 A

XJC01_06

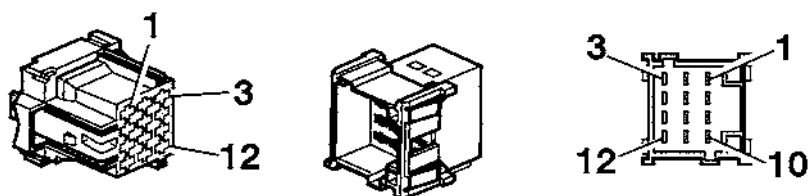

T3019801

Pin no:	Circuit function	Wiring no:	Diagram
1	Cab heater control	476	AB_Hyb:0 D
1	ADR alternator relay control	2126	AE:1 D
2	Power supply kl. 30	2304	AB_Hyb:0 D
2	Ground when main switch open	2226	AE:1 D
3	Front door switch control/instep lights control	119/4322	GH1:2 D/GH5:2 D
4	Ground	1	AE:1 D
5	Starter relay control	5102	CU22:0 C
6	Ground	1	IM:4 D
7	Neutral gearbox information	12	BA:3 C
8	Neutral gearbox information	12	BA:3 B
9	Bus J1587-1 diagnostic line (B-)	0011	XA:2 C
10	Power supply kl. 15	4309	AG:2 E
11	Bus J1587-1 diagnostic line (A+)	0010	XA:2 C
12	Power supply kl. 30	2327	BT:1 B

XJC01_07

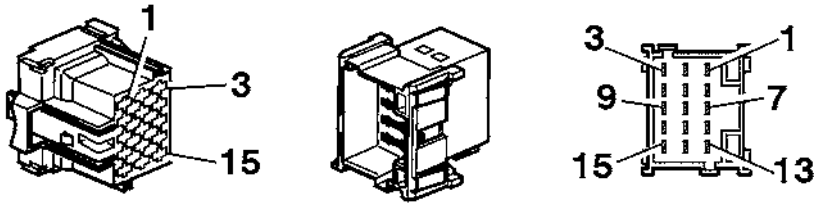

T3019800

Pin no:	Circuit function	Wiring no:	Diagram
1	Dashboard switch power supply from VECU	2123	BA:3 A
2	Ground	1	BA:1 D
3	Ground	1	DN:0 A/DQ1:1 B
5	Ground	1	EM1:2 B
6	Beacon warnings lamps power supply	323	GC2:3 C
7	Power supply kl. 30	2331	IR:3 A
8	Power supply kl. 15	273	AI:1 D
9	Dashboard illumination power supply	64	DU:2 A
10	Engine running power supply	2229	AE:4 E
11	Power supply kl. 15	2317	AI:3 D
13	Power supply kl. 15	273	AI:1 D
14	Power supply kl. 15	2317	AB_Hyb:0 C
15	Dashboard switch power supply from VECU	2124	BA:3 E

XJC01_08

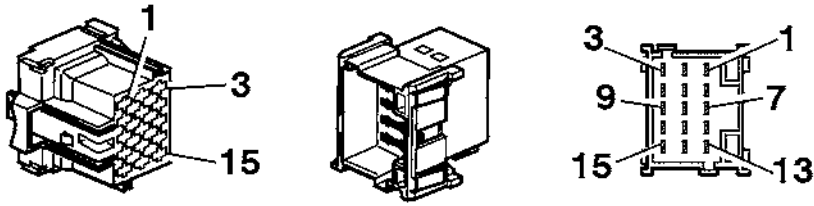

T3019800

Pin no:	Circuit function	Wiring no:	Diagram
1	Ground	1	IU:2 B
2	Ground	1	IF1:4 E
3	Ground	1	GD:0 D
4	Power supply kl. 30	452	GF1:2 C
5	Ground	1	IA:3 D
6	Dashboard illumination power supply	64	IA:3 B
8	Ground	1	IU.3 D
9	Front door switch control/instep lights control	119	GH1:2 D/GH5:2 D
10	Power supply kl. 15	4308	IA:3 B
11	Ground	1	IR:4 B
12	Power supply kl. 30	45	GH1:2 B/GH5:2 B
13	Power supply kl. 15	2231	AG:4 E

XJC01_09

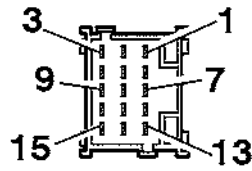
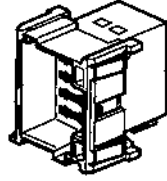
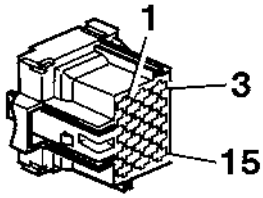

T3019800

Pin no:	Circuit function	Wiring no:	Diagram
1	Power supply kl. 15	2014	HY:0 C
2	Dashboard illumination power supply	64	GH1:4 B
3	Power supply after Optidriver 2 power supply relay	2127	DN:3 B
3	Ground	1	DQ1:1 B
4	Dashboard illumination power supply	64	HY:2 A
5	Dashboard illumination power supply	64	FA:4 C/FA2:3 A
6	Power supply kl. 30	270	DN:3 B
6	Neutral gearbox information	12	DQ1:1 A
7	Power supply kl. 15	2234	NA:3 B
8	Power supply after relay air suspension	260	FA:4 B/FA1:4 C
9	Power supply after relay air suspension	260	FA:4 B/FA1:4 C/FA2:4 C
10	Power supply after relay air suspension	260	FA:4 B/FA1:4 C/FA2:4 C
11	Power supply kl. 30	2331	IR:4 A
12	Power supply kl. 30	666	GH1:4 B
13	Power supply kl. 15	2117	AE:3 A
14	Optidriver 2 power supply relay control	2320	DN:3 B
14	Allison relay control	5031	DQ1:1 B
15	Ground	1	DN:3 B/DQ1:1 B

XJC01_10

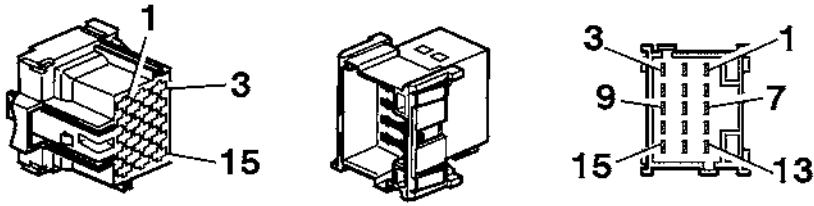

T3019800

Pin no:	Circuit function	Wiring no:	Diagram
2	Heater status	4003	HJ:0 A/HJ1:0 A
3	Bus J1587-1 diagnostic line (B-)	0011	XA:2 B
4	Ground	1	GH1:4 C
5	Ground	1	FA:3 C/FA1:4 D/FA2:3 D
6	Ground	1	FA:3 C/FA1:4 D/FA2:4 D
7	Ground	1	FA:3 C
8	Ground	1	FA:3 D/FA1:4 D/FA2:4 D
9	Power supply kl. 15	274	FA:3 B/FA1:3 B/FA2:3 C
10	Power supply kl. 30	2304	HY:3 C
11	Power supply kl. 30	2304	AB_Hyb:0 C
12	Front fog light control	69	GB2:0 B
13	Bus J1587-1 diagnostic line (A+)	0010	XA:2 B
14	Front fog light power supply	60	BK:4 B
15	Air suspension relay control	1155	FA:3 B/FA1:4 B/FA2:4 C

XJC01_11

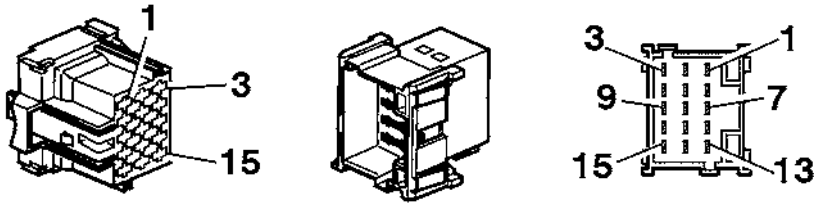

T3019800

Pin no:	Circuit function	Wiring no:	Diagram
1	Parking heater fuel dosing pump control	414	HJ:4 D/HJ1:4 D
2	Parking light	2128	GA2:3 C
6	ADR alternator relay control	2126	AE:2 D
7	Cab heater control	476	BK:2 D
8	Dashboard switch power supply from VECU	2124	BA:3 E
9	Dashboard switch power supply from VECU	2124	BA:3 E
11	Parking heater fuel dosing pump ground	413	HJ:4 D/HJ1:4 D
15	Power supply kl. 30	2311	GA2:4 C

XJC01_12

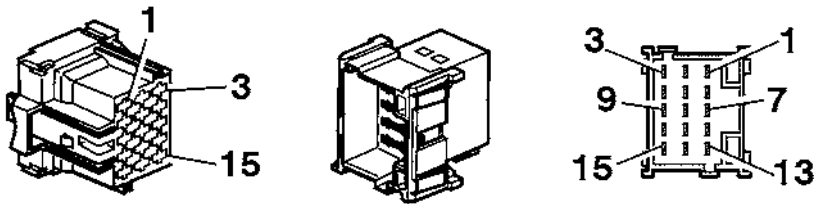

T3019800

Pin no:	Circuit function	Wiring no:	Diagram
1	Ground	1	BM:2 C
2	PTO 1 feedback (speed 1)	88	NB:3 D
3	Power supply kl. 30	2328	AA:1 A
4	Ground	1	IF1:4 E
6	Dashboard illumination power supply	64	NB:0 A
7	Ground	1	CU23:0 B
9	Power supply kl. 30	2328	AA:2 A
10	Front door switch control/instep lights control	119/4322	GH1:3 D/GH5:2 D
14	Front door switch control/instep lights control	119/4322	GH1:2 D/GH52 D

XJC01_13

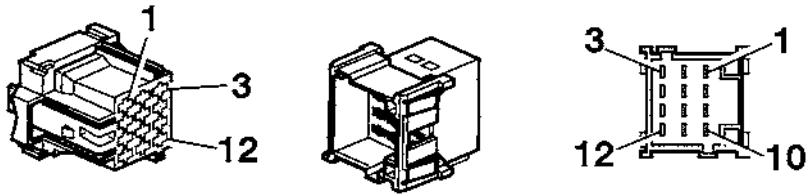

T3019801

Pin no:	Circuit function	Wiring no:	Diagram
2	Dashboard illumination power supply	64	BA:0 D
3	Horn control	311	GQ:1:1 D
4	Horn relay control	312	GQ:1:1 B
6	Seat belt reminder	775	BK:3 B
7	Dashboard illumination power supply	64	DU:3 A
10	Dashboard illumination power supply	64	BA:2 A
11	Dashboard illumination power supply	64	DQ:1:4 A
12	Diff lock rear inter axle feedback	86	DU:2 C

XJC01_14

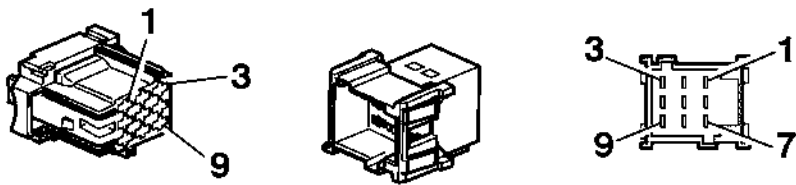

T3019929

Pin no:	Circuit function	Wiring no:	Diagram
1	Power supply kl. 30	247	KA:1 A
3	Power supply kl. 30	5095	GM:1 B
4	Power supply kl. 30	270	DN:3 A/DQ1:0 B
5	Ground	1	BA:3 B
6	Diff lock rear wheel control	8129	DU:3 C
7	Ground	1	DN:0 A/DQ1:0 E
8	Power supply kl. 15	2121	DU:2 A

XJC01_15

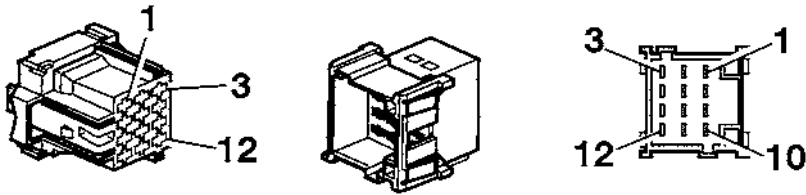

T3019801

Pin no:	Circuit function	Wiring no:	Diagram
1	Power supply kl. 15	2121	DU:3 A
2	Power supply kl. 15	2315	AG:4 E
4	Power supply kl. 15	456	AG:3 E
5	Power supply kl. 15	2231	AG:3 E
7	Power supply kl. 30	2312	BT:2 B
8	Ground	1	NB:4 B
9	Ground	1	BT:0 B
10	Power supply kl. 15	2325	AJ:2 D
11	Bus J1587-1 diagnostic line (A+)	0010	XA:3 C
12	Bus J1587-1 diagnostic line (B-)	0011	XA:3 C

XJC01_16

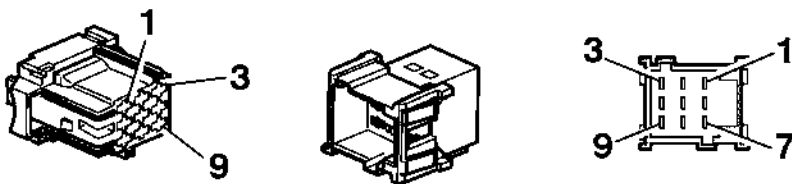

T3019929

Pin no:	Circuit function	Wiring no:	Diagram
1	EBS trailer brake switch	5089	EM2:4 C
2	Bus J1587-1 diagnostic line (A+)	0010	XA:2 B
3	Power supply kl. 15	2232	IQ:3 A
4	Heated mirror ON/OFF	4060	BA:0 B
5	Power supply kl. 15	215	IF1:0 B
6	Bus J1587-1 diagnostic line (B-)	0011	XA:2 B
7	Power supply kl. 15	2025	EM1:3 B
8	Ground	1	FC:1 E
9	Key inserted	169	AB:0 A

XJC01_17

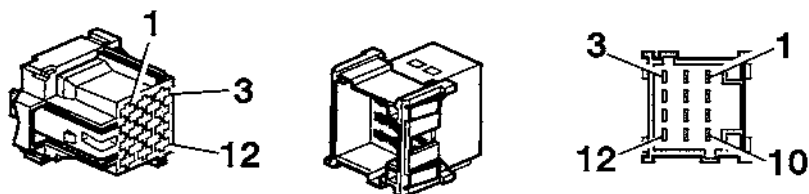

T3019801

Pin no:	Circuit function	Wiring no:	Diagram
1	Ground	1	AB:1 B
2	Ground	1	EM1:3 B
3	Ground	1	NB:0 B
4	Dashboard illumination power supply	64	EM2:3 A
5	Dashboard illumination power supply	64	IU:1 B
6	Ground	1	EM2:3 B
7	Power supply kl. 30	2309	EM1:3 B
8	Heated mirror power supply. Windscreen heater relay control	4	IF1:2 B
9	Ground	1	GC5:1 A
10	Power supply kl. 30	2309	EM1:4 B
11	Heated mirror power supply. Windscreen heater relay control	4	IF1:2 B
12	Power supply for heater	2132	AE:3 C

XJC01_18

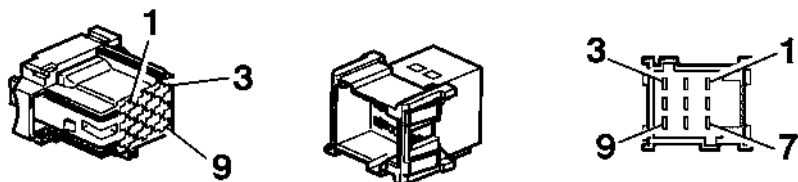

T3019929

Pin no:	Circuit function	Wiring no:	Diagram
1	Power supply kl. 15	2121	DQ:4 A
2	Power supply kl. 15	2121	AJ:4 D
3	Bus J1587-1 diagnostic line (B-)	0011	XA:2 B
4	Bus J1587-1 diagnostic line (A+)	0010	XA:3 B
6	Power supply kl. 15	2310	AH:3 D
7	Power supply kl. 15	243	KA:1 A
8	K diagnostic line	851	GF1:2 A

XJC01_19

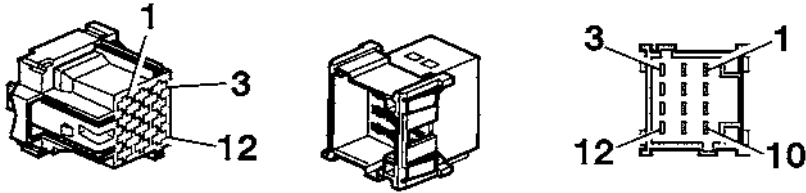

T3019801

Pin no:	Circuit function	Wiring no:	Diagram
1	Heated mirror power supply. Windscreen heater relay control	4	IF1:3 B
2	Ground	1	DN:4 B/DQ1:1 B
3	Power supply kl. 30	321	GC2:3 A
4	Ground	1	IR:1 B/IR1:2 B
5	Ground	1	DU:3 B
8	Ground	1	BA:0 E
10	Engine running power supply	4306	AB:4 E/AE:4 E
11	Ground	1	IN:3 E
12	Power supply kl. 15	5098	AJ:0 D

XJC40

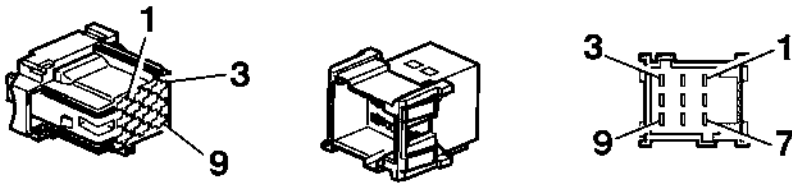

T3019929

Pin no:	Circuit function	Wiring no:	Diagram
1	Bus J1587-1 diagnostic line (B-)	0011	XA:1 B
4	Bus J1587-1 diagnostic line (A+)	0010	XA:1 B

XJE21

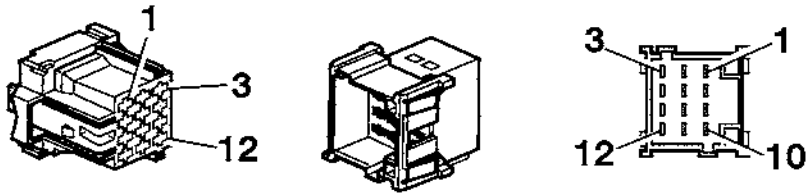

T3019801

Pin no:	Circuit function	Wiring no:	Diagram
1	Bus J1587-1 diagnostic line (B-)	0011	XA:3 B
2	Power supply, starter relay	5101	CU22:0 C
3	Power supply after relay K2	291	CU20:0 B
4	Alternator engine running; generating current	25	AB:2 C/AE:2 C
5	Bus J1587-1 diagnostic line (A+)	0010	XA:3 C
6	Power supply after relay K2	291	CU20:1 B
7	Ground when main switch open	2226	AB:1 D/AE:1 D
8	Power supply kl. 15	808	CU22:3 B
9	Power supply after relay K2	2329	CU20:0 B
10	Power supply after relay K2	292	CU20:0 B
11	Ground	1	CU20:1 D
12	Power supply after relay K2	2323	CU22:1 B

XJF01

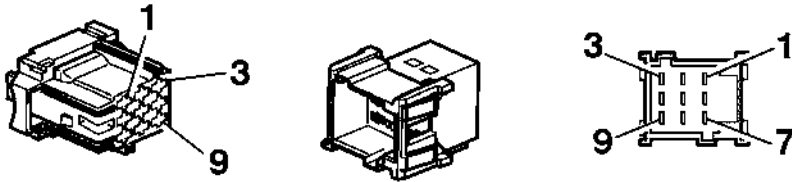

T3019929

Pin no:	Circuit function	Wiring no:	Diagram
2	Right front high beam lights power supply	602	GC5:2 C
4	Front fog light power supply	60	GC5:4 C
5	Parking lights left side	305	GC5:0 C
6	Parking lights right side	304	GC5:2 C
7	Relay park brake trigger control	8109	KA:1 C
8	Left front high beam lights power supply	603	GC5:0 C

XJF01_R

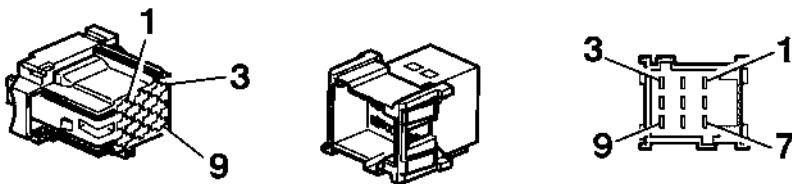

T3019929

Pin no:	Circuit function	Wiring no:	Diagram
2	Right front high beam lights power supply	602	GC5:2 C
4	Front fog light power supply	60	GC5:4 C
5	Parking lights left side	305	GC5:0 C
6	Parking lights right side	304	GC5:2 C
7	Relay park brake trigger control	8109	KA:1 C
8	Left front high beam lights power supply	603	GC5:0 C

XJH50

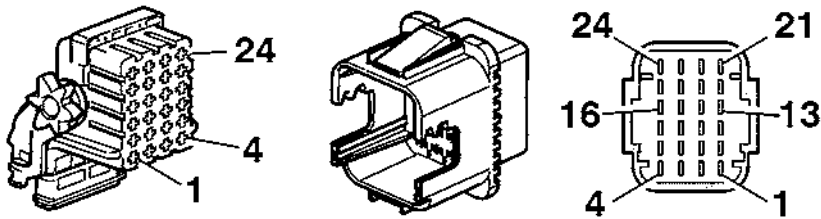

T3019802

Pin no:	Circuit function	Wiring no:	Diagram
1	Main switch command	147	IM:3 C
2	Key inserted	169	IN:4 C
3	Cab heater control	476	IN:1 B
4	Ground	1	IM:3 E
5	Direct battery	203	BM:2 B
6	Ground	1	GA2:4 D
7	Ground	1	BM:2 C
8	Power supply kl. 15	24	IM:1 B
9	Dashboard illumination power supply	64	IN:2 A
11	Ground	1	GH3:2 D/GH5:3 D
12	Ground	1	GH5:0 D
13	Unlock door request	484	IM:1 C
15	Ground	1	GC2:3 E
16	Front door switch control/instep lights control	4321/119	GH1:1 C/GH5:1 C
17	Lock door request	436	IM:1 C
18	Power supply kl. 30	45	GH1:1 B/GH5:1 B
19	Power supply kl. 30	45	GH3:2 B/GH5:3 B
21	Parking lights left side	305	GC2:2 A
24	Power supply kl. 30	263	IM:0 B

XJH51

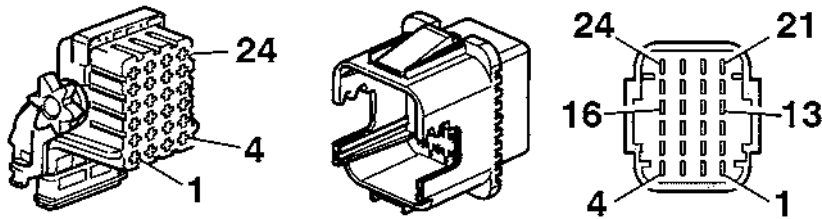

T3019802

Pin no:	Circuit function	Wiring no:	Diagram
2	Coded line alarm trailer connection freight	0403	IN:2 D
3	Beacon warning lamps power supply	323	GC2:3 C
5	Ground	1	GD:2 D
7	Ground	1	GA2:4 D
8	Reverse lights buzzer	635	GD:2 D
9	Bus J1587-1 diagnostic line (A+)	0010	XA:1 B
11	Ground	1	IR:1 B
12	Reverse lights ON-OFF, and power supply	608	GD:2 C
13	Bus J1587-1 diagnostic line (B-)	0011	XA:1 B
14	Ground	1	IR:0 D
15	Ground	1	GC2:2 C
17	Power supply kl. 15	4309	IR:1 B
18	Sun-roof motor control	4014	IQ:1 C
19	Dashboard illumination power supply	64	GC2:3 A
20	Power supply kl. 30	321	GC2:3 A
21	Sun-roof motor control	4015	IQ:1 C
24	Power supply kl. 15	229	BM:1 A

XJH52

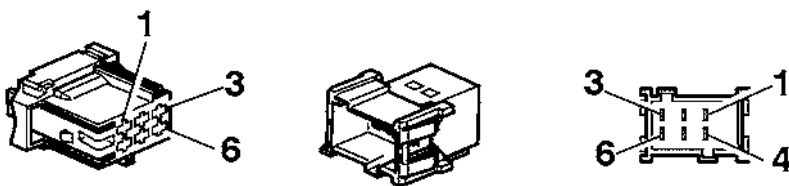

T3019918

Pin no:	Circuit function	Wiring no:	Diagram
1	Dashboard illumination power supply	64	GD:2 C
2	Power supply kl. 30	2302	IR:2 B
3	Parking light	2128	GA2:4 D
4	Power supply kl. 15	2315	IR:0 D
6	Power supply kl. 30	2311	GA2:4 D

XJR11

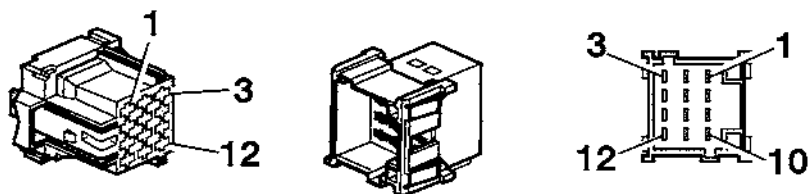

T3019801

Pin no:	Circuit function	Wiring no:	Diagram
2	Parking lights left side	305	GC3:0 B
3	ADR main switch closing request	5070	AC:2 B
4	Brake lights power supply	3	GC3:2 B
5	Reverse lights ON-OFF, and power supply	608	GC3:1 B
6	ADR main switch closing request	5067	AC:2 B
7	Rear fog lights power supply	307	GC3:2 A
8	Ground	1	DU:3 D
9	Reverse lights buzzer	635	GC3:4 B
11	Ground	1	GC4:3 E
12	Parking lights right side	304	GC3:3 A

XJR13_R

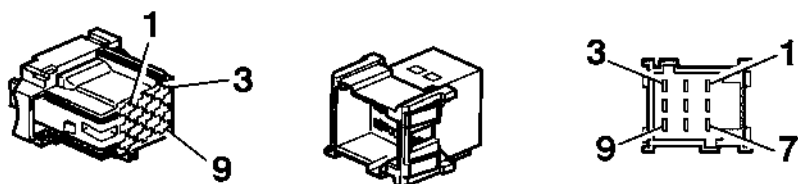

T3019929

Pin no:	Circuit function	Wiring no:	Diagram
2	Rear left marker	632	GF:3 D
3	Power supply kl. 15	211	GF:1 B
4	Rear right marker	634	GF:3 D
6	Coded line alarm trailer connection freight	0403	GF:4 D
8	Power supply kl. 15	606	GF:4 B

XJR13_T

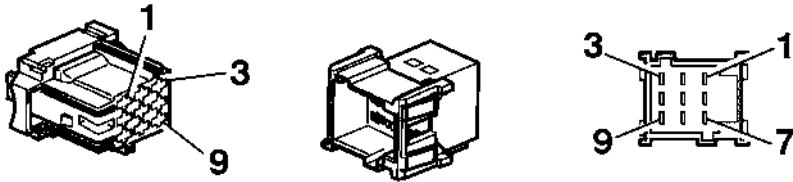

T3019929

Pin no:	Circuit function	Wiring no:	Diagram
2	Rear left marker	632	GF:3 D
3	Power supply kl. 15	211	GF:1 B
4	Rear right marker	634	GF:3 D
5	Rear fog lights power supply	307	GF:4 D
6	Coded line alarm trailer connection freight	0403	GF:4 D
7	Brake lights power supply	3	GF:3 B
8	Power supply kl. 15	606	GF:4 B
9	Reverse lights ON-OFF, and power supply	608	GF:3 B

XJR14_R

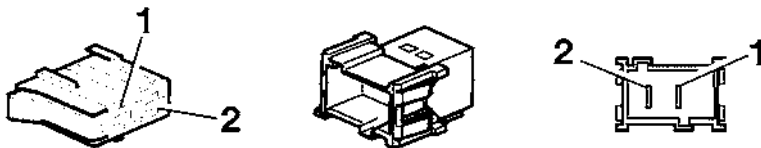

T3019930

Pin no:	Circuit function	Wiring no:	Diagram
1	Power supply kl. 30	522	GF:1 B

XJR14_T

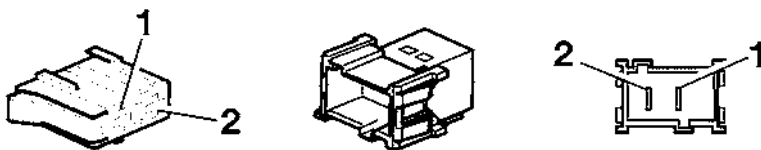

T3019930

Pin no:	Circuit function	Wiring no:	Diagram
1	Power supply kl. 30	522	GF:1 B

XJR32

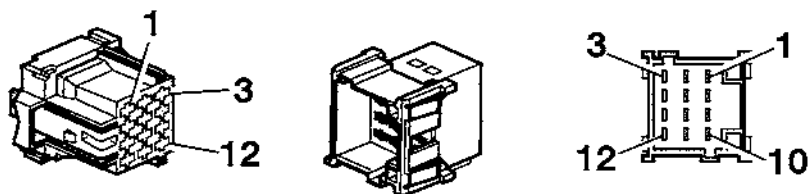

T3019801

Pin no:	Circuit function	Wiring no:	Diagram
1	Ground	1	EM2:3 E
2	Power supply kl. 15	2117	AC:2 A
3	ADR main switch closing request	5070	AC:2 B
5	ADR main switch closing request	5067	AC:2 B
6	Key inserted info	5066	AC:2 A
8	ADR main switch led ground	1149	AC:2 B
9	EBS trailer brake switch	5089	EM2:4 D
10	Dashboard illumination power supply	64	EM2:4 D

XJR33

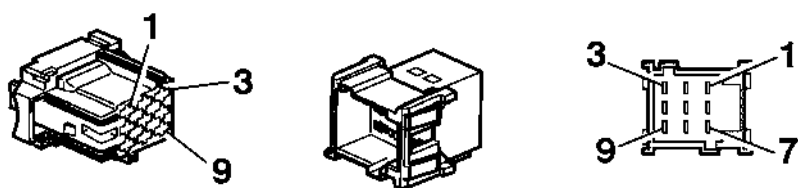

T3019929

Pin no:	Circuit function	Wiring no:	Diagram
1	Lock door request	436	IM:1 B
2	Sun-roof motor control	4015	IQ:1 C
3	Sun-roof motor control	4014	IQ:1 C
4	Unlock door request	484	IM:1 B
7	Ground	1	IM:2 B
8	Power supply kl. 15	2231	IQ:1 A
9	Dashboard illumination power supply	64	IQ:1 C

XJR61

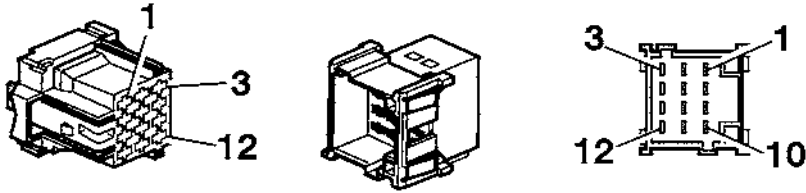

T3019801

Pin no:	Circuit function	Wiring no:	Diagram
1	Cab heater control	476	HJ:2 A/HJ1:2 B
2	K diagnostic line	851	HJ:3 D/HJ1:3 C
3	Parking heater push button request	4467	HJ:0 A/HJ1:1 B
4	Power supply for heater	2132	AE:3 C/HJ:3 A
6	Power supply kl. 15	2014	HY:0 B
7	Dashboard illumination power supply	64	HJ:2 A/HJ1:2 A
8	Power supply kl. 30	2304	HJ:2 A/HJ1:2 B
10	Ground	1	HJ:3 E/HJ1:3 E
11	Heater fuel dosing pump ground	413	HJ:3 D/HJ1:3 D
12	Heater fuel dosing pump control	414	HJ:3 D/HJ1:3 D

XJR62

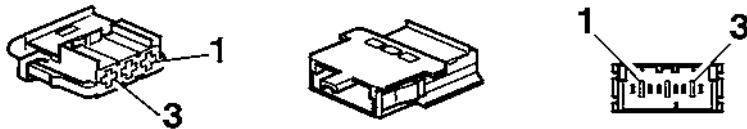

T3019921

Pin no:	Circuit function	Wiring no:	Diagram
1	Engine running power supply	2229	AB:3 E/HJ1:3 B
3	PTO 1 feedback (speed 1)	88	HJ1:3 B

XJR64

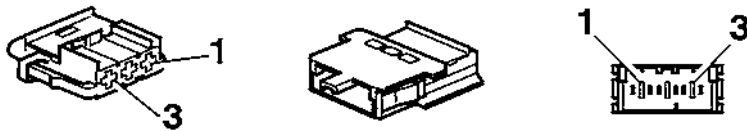

T3019921

Pin no:	Circuit function	Wiring no:	Diagram
1	Ground	1	IR:4 E
3	Power supply kl. 30	2302	IR:3 C

XJR65

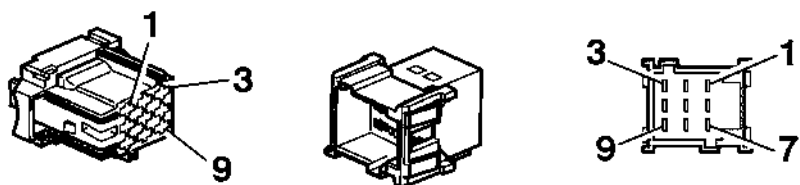

T3019929

Pin no:	Circuit function	Wiring no:	Diagram
2	Engine running power supply	4306	IA:0 B
3	Engine running power supply	4306	IA:2 B
6	Seat belt reminder	775	IA:3 B
8	Ground	1	IA:2 E

XJR73

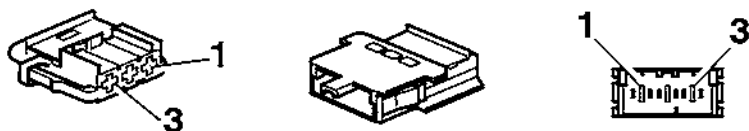

T3019921

Pin no:	Circuit function	Wiring no:	Diagram
2	Ground	1	KA:3 C
3	Engine running power supply	2229	KA:3 B

XJR80

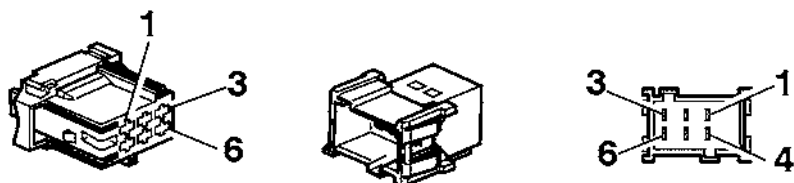

T3019918

Pin no:	Circuit function	Wiring no:	Diagram
3	Power supply kl. 30	45	GH1:3 B
4	Ground	1	GH1:3 D
5	Front door switch control/instep lights control	119/4322	GH1:2 D/GH5:2 D

XT02

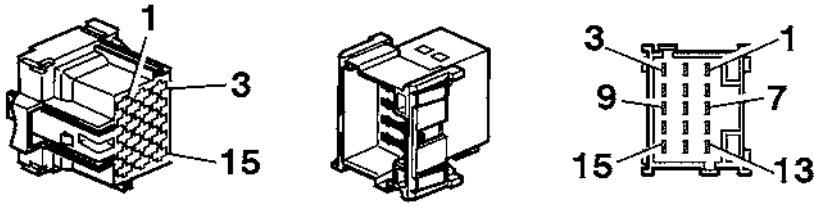

T3019800

Pin no:	Circuit function	Wiring no:	Diagram
1	Tilt cab relay control	8111	KA:1 B
2	Front/door right turn indicator	37	GC5:2 B
3	Front/door left turn indicator	302	GC5:0 C
4	Cab tilt pump	485	KA:1 C
5	Horn control	311	GQ1:3 C
6	Low beam lights ON-OFF control	604	GC5:0 C
7	Windscreen washer pump supply and headlamp washer pump request	506	GM:0 D
8	Power supply headlamp washer pump	5094	GM:1 D
9	Front headlights angle control 12V power supply	388	GC5:3 C
10	Front headlights angle control	437	GC5:1 B
11	Low beam lights ON-OFF control	605	GC5:2 C

XT02_R

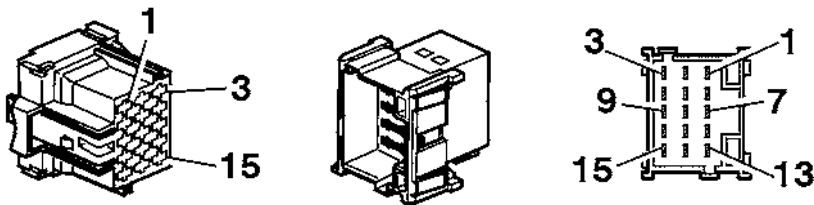

T3019800

Pin no:	Circuit function	Wiring no:	Diagram
1	Tilt cab relay control	8111	KA:1 B
2	Front/door right turn indicator	37	GC5:2 B
3	Front/door left turn indicator	302	GC5:0 C
4	Cab tilt pump	485	KA:2 C
6	Low beam lights ON-OFF control	604	GC5:0 C
7	Windscreen washer pump supply and headlamp washer pump request	506	GM:0 D
8	Power supply headlamp washer pump	5094	GM:1 D
9	Front headlights angle control 12V power supply	388	GC5:3 C
10	Front headlights angle control	437	GC5:1 B
11	Low beam lights ON-OFF control	605	GC5:2 C

XT12

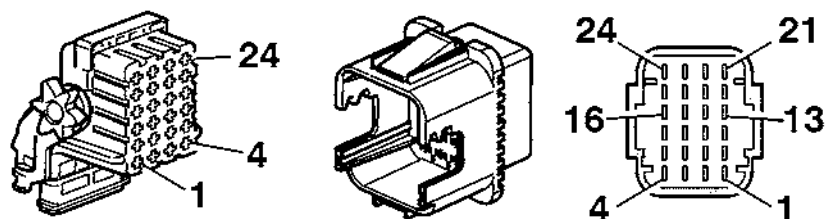

T3019802

Pin no:	Circuit function	Wiring no:	Diagram
1	Rear right turn indicator	38	GC3:4 B
2	Rear left turn indicator	301	GC3:1 A
3	Ground	1	FA1:3 A/FA2:3 A
4	Heater fuel dosing pump ground	413	HJ:4 D/HJ1:4 D
5	EBS yaw-rate and steering angle dedicated CAN bus H line	0415	EM2:1 B
6	EBS yaw-rate and steering angle dedicated CAN bus L line	0416	EM2:1 B
7	ESP sensor ground	1124	EM2:1 B
8	ESP sensor power supply	5048	EM2:1 B
9	Ground	1	BK:3 E
11	Disc brake pad sensor	8040	BK:3 D
12	Fuel level sensor (+)	76	BK:1 C
14	Fuel level sensor (-)	718	BK:0 D
15	Air filter restriction	720	BK:1 C
16	Diff lock rear wheel control	8129	DU:3 C
17	Heater fuel dosing pump control	414	HJ:4 D/HJ1:4 D
18	Diff lock rear wheels axle 1	87	DU:3 B
19	Bodybuilder predisposition switch	0461	NC:3 B
20	Bodybuilder predisposition switch	0460	NC:3 B
23	Chassis/equipment	8116	NC:3 B

XT13

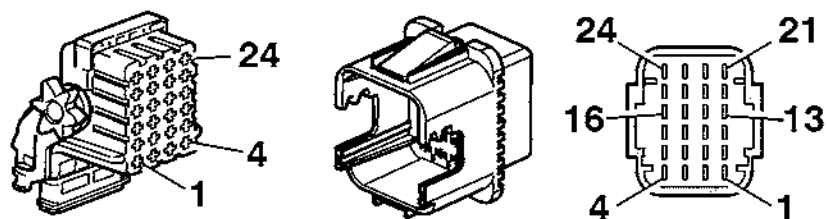

T3019802

Pin no:	Circuit function	Wiring no:	Diagram
15	ADR main switch closing request	5069	AC:2 C
16	ADR main switch closing request	5068	AC:2 C
17	Diff. lock rear wheels axle 2	8098	DU:4 B
18	Diff. lock rear inter axle feedback	86	DU:2 C

XT14_R

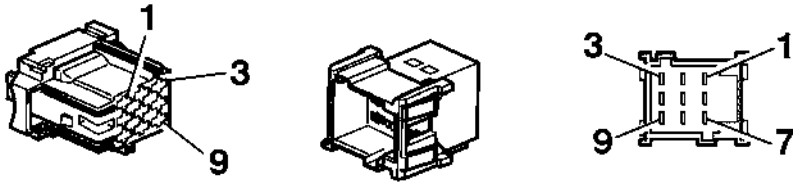

T3019929

Pin no:	Circuit function	Wiring no:	Diagram
1	ABS trailer state	352	GF:0 B
2	Trailer turn right indicator	30	GF:4 B
4	Trailer turn left indicator	39	GF:4 B
5	Chassis lighting or valve lighting	618	GF:3 B
7	Trailer CAN bus: L line	0046	GF:0 B
8	Trailer CAN bus: H line	0045	GF:0 B

XT14_T

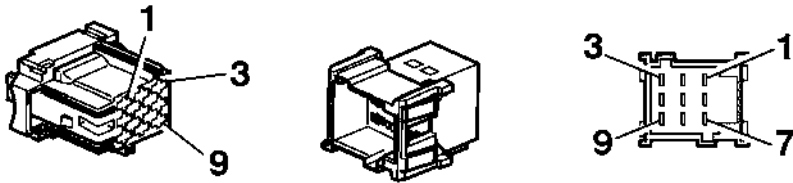

T3019929

Pin no:	Circuit function	Wiring no:	Diagram
1	ABS trailer state	352	GF:0 B
2	Trailer turn right indicator	30	GF:4 B
4	Trailer turn left indicator	39	GF:4 B
5	Chassis lighting or valve lighting	618	GF:3 B
7	Trailer CAN bus: L line	0046	GF:1 B
8	Trailer CAN bus: H line	0045	GF:0 B
9	Loading	607	GH1:4 C

XT22

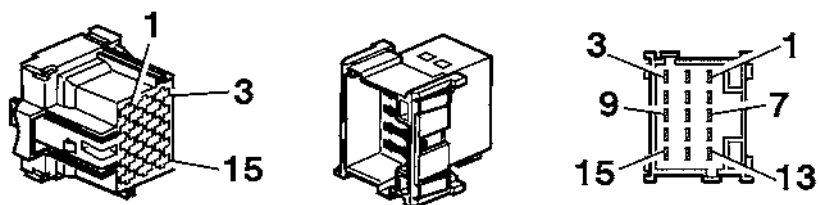

T3019800

Pin no:	Circuit function	Wiring no:	Diagram
1	Climate compressor power supply	462	HY:3 D
2	Preheater feedback	803	BK:0 B
3	Cab heater control	476	AB_Hyb:1 C
4	Engine speed "W" alternator termination	7	AB:1 C/AE:0 C
5	J1939 CAN-1 Bus high	0012	XB:3 A
6	J1939 CAN-1 Bus low	0013	XB:3 A
7	Power supply kl. 15	5098	CU22:4 C
8	Idle validation switch	5072	BA:0 D
9	Ground	1	CU23:0 C
10	CAN Hybrid high level	0049	IO1_Hyb:4 D
11	CAN Hybrid low level	0048	IO1_Hyb:4 D
12	Ground	1	CU23:0 C
13	Can ODB (+)	0462	XD:1 B
14	Can ODB (-)	0463	XD:1 B
15	Power supply kl. 30	2328	CU23:2 C

XT32

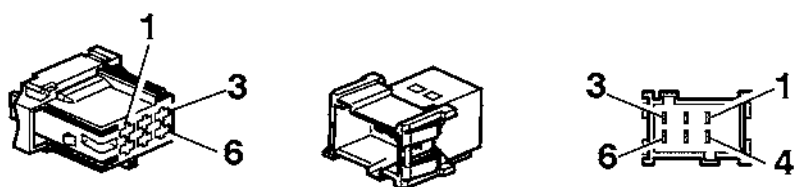

T3019918

Pin no:	Circuit function	Wiring no:	Diagram
1	Tachograph speed sensor supply	142	BM:2 C
3	Ground (tachograph)	825	BM:2 C
3	Ground (speedometer)	1	BM:2 C
4	Speed signal real time	141	BM:2 C
6	Tachograph data signal	0056	BM:2 C

XT33

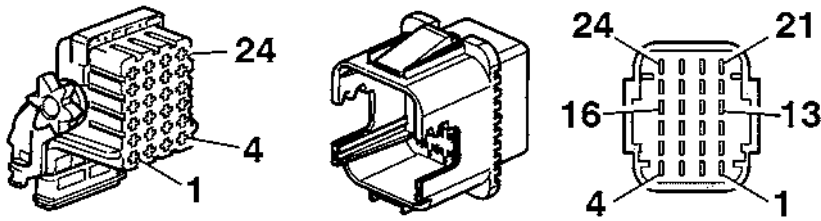

T3019802

Pin no:	Circuit function	Wiring no:	Diagram
1	Automatic transmission relay control	5031	DQ1:1 B
2	EBS brake hold enable	5085	DQ1:3 B
3	J1587 low level for allison gear box diagnostic plug	0068	DQ1:2 C
4	Range redundancy	5109	DQ1:4 C
5	Power supply kl. 15	2121	DQ:1 C
6	Can ODB (+)	0462	DN:0 B
6	Manual gear box reverse gear switch	661	GD:0 B
7	Neutral gear box information	12	BA:3 B
7	Can ODB (-)	0463	DN:0 B
8	PTO 1 feedback (speed 1)	88	DQ:1 B
9	Power supply kl. 15	2121	DQ:3 B
10	PTO 2 valve control	8161	DQ:3 D
11	PTO 1 valve	8093	DQ:1 D
12	PTO 2 feedback	8134	DQ:3 C
13	Ground	1	GD:0 D
14	Ground	1	DN:0 B/DQ1:0 D
15	Ground	1	DN:0 B
15	J1587 high level for allison gear box diagnostic plug	0067	DQ1:2 C
16	Power supply after Optidriver 2 power supply relay	2127	DN:3 B
16	Power supply kl. 30	270	DQ1:0 B
17	J1939 CAN-1 Bus high	0012	XB:3 B
18	J1939 CAN-1 Bus low	0013	XB:3 B
19	Power supply after Optidriver 2 power supply relay	2127	DN:3 B
19	Power supply kl. 30	270	DQ1:0 B
20	Power supply kl. 15	2325	DQ1:0 B
21	J1939 CAN-1 Bus high	0012	XB:3 B
22	J1939 CAN-1 Bus low	0013	XB:3 C
23	Bus J1587-1 diagnostic line (A+)	0010	XA:3 A
24	Bus J1587-1 diagnostic line (B-)	0011	XA:3 B

XT42

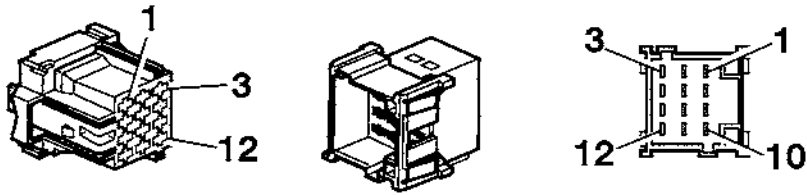

T3019801

Pin no:	Circuit function	Wiring no:	Diagram
1	Ground	1	FC:1 D/FC1:2 D
3	Ground when main switch open	2226	AB:2 E
3	ADR alternator relay control	1150	AE:1 E
5	ADR main switch closing request	5069	AC:2 C
6	ADR main switch closing request	5068	AC:2 C
7	Power supply body builder on chassis	2057	NB:3 D
8	Direct battery	203	BM:2 A
9	Power supply kl. 30	2328	CU23:2 B
11	J1939 CAN-1 Bus high	0012	XB:3 D
12	J1939 CAN-1 Bus low	0013	XB:3 D

XT53

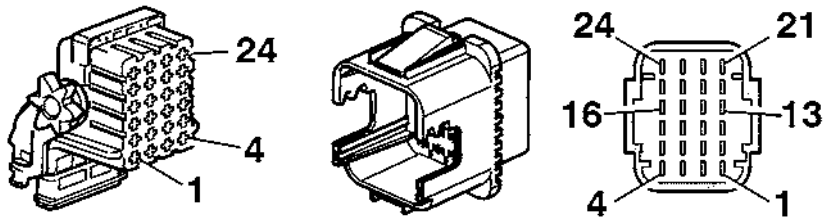

T3019802

Pin no:	Circuit function	Wiring no:	Diagram
1	Rear axle bellow suspension control	8148	FA2:1 B
2	Lift axle bellow	8149	FA2:2 B
3	Air inlet/outlet	8150	FA2:2 B
4	ECS rear axle bellow air pressure sensor	8156	FA2:0 D
9	EBS 1st additional module dedicated CAN H	0149	EM1:0 D
10	EBS 1st additional module dedicated CAN L	0150	EM1:0 D
11	EBS 1st additional module power supply	5083	EM1:0 D
12	EBS 1st additional module ground	5084	EM1:0 D
13	U mini sensor steering angle front	0119	FO:2 C
14	U maxi sensor steering angle front	0120	FO:2 C
15	Power supply kl. 30	2233	FO:1 B
16	EBS lift axle bellow air pressure sensor	8157	FA2:0 D
17	Ground	1	FO:1 C
18	Ground	1	FO:1 C
19	Power supply kl. 15	274	FO:1 B
20	Ground	1	FA2:3 A
21	Sensor oil level	8079	FO:1 B
22	Electronic steered axle sensor ground	1081	FO:2 C
23	ECS pressure sensors power supply	8077	FA2:0 D
24	Air suspension pressure sensor GND	899	FA2:0 E

XT54

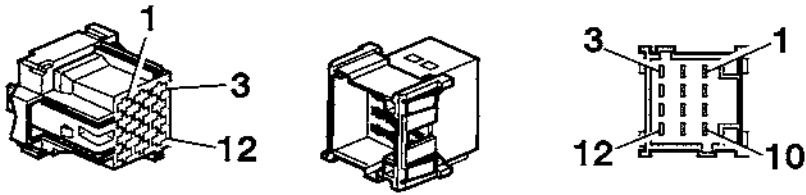

T3019801

Pin no:	Circuit function	Wiring no:	Diagram
1	EBS trailer control module pressure sensor supply	0376	EM2:1 C
2	EBS trailer control module pressure sensor signal	0377	EM2:1 C
3	EBS trailer control module pressure sensor ground	0380	EM2:2 C
4	EBS trailer control module power supply	5050	EM2:2 C
5	EBS TCM inlet valve control	5091	EM2:2 C
6	EBS TCM outlet valve control	5092	EM2:3 C
7	EBS TCM backup valve control	5093	EM2:3 C
12	Power supply kl. 15	2121	JB3_Hyb:1 A

XT55

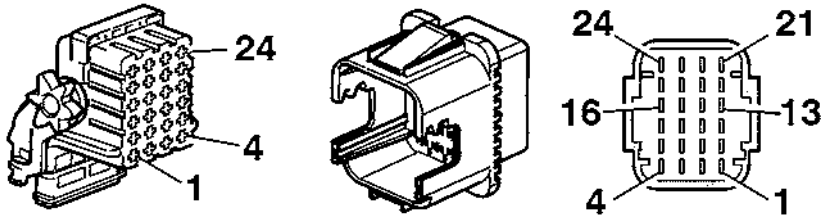

T3019802

Pin no:	Circuit function	Wiring no:	Diagram
1	Ground	1	FA:2 A/FA1:3 A/FA2:3 A
2	Drive axle valve air inlet/outlet control	813	FA:0 B/FA1:1 B/FA2:1 B
3	Rear right axle bellow valve control	814	FA:0 B/FA1: 0 B/FA2:0 B
4	Rear left axle bellow valve control	815	FA:0 B/FA1:1 B/FA2:1 B
5	Sensor, chassis level, rhs. rear axle	881	FA:2 D/FA1:2 D/FA2:2 D
6	Chassis level rear axle sensor -	8140	FA:2 D/FA1:2 D/FA2:2 D
7	Chassis level rear axle sensor +	8142	FA:2 D/FA1:2 D/FA2:2 D
8	Air suspension pressure sensor GND	899	FA:1 D/FA1:2 D/FA2:1 D
9	Sensor, chassis level, lhs. rear axle	880	FA:1 D/FA1:2 D/FA2:2 D
10	ECS rear right axle air pressure sensor	8159	FA:0 D/FA1:1 D/FA2:1 D
11	ECS rear right axle air pressure sensor	8160	FA:1 D/FA1:1 D/FA2:1 D
12	ECS pressure sensors power supply	8077	FA:1 D/FA1:1 D/FA2:1 D
13	Front axle bellow valve control	816	FA1:0 B/FA2:0 B
21	EBS rear module dedicated CAN L	064	EM1:1 D
22	EBS rear module dedicated CAN H	066	EM1:1 D
23	EBS rear module +24V power supply	5081	EM1:0 D/EM1:1 D
24	EBS rear module ground	5082	EM1:0 D/EM1:1 D

XT56

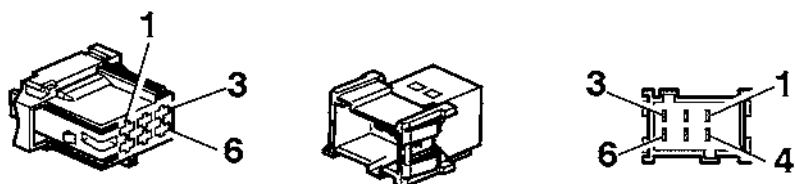

T3019918

Pin no:	Circuit function	Wiring no:	Diagram
1	Sensor chassis level front axle	879	FA1:2 D/ FA2:1 D
2	Chassis level rear axle sensor –	8140	FA1:2 D/ FA2:1 D
3	Chassis level rear axle sensor +	8142	FA1:2 D/ FA2:1 D
4	Air suspension pressure sensor ground	899	FA1:1 D/ FA2:1 D
5	ECS pressure sensors power supply	8077	FA1:0 D/ FA2:0 D
6	ECS rear left axle air pressure sensor	8158	FA1:1 D/ FA2:1 D

XT56_R

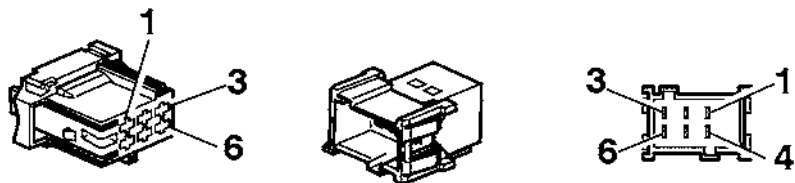

T3019918

Pin no:	Circuit function	Wiring no:	Diagram
1	Sensor chassis level front axle	879	FA2:2 D
2	Chassis level rear axle sensor –	8140	FA2:2 D
3	Chassis level rear axle sensor +	8142	FA2:2 D
4	Air suspension pressure sensor ground	899	FA2:1 D
5	ECS pressure sensors power supply	8077	FA2:0 D
6	ECS rear left axle air pressure sensor	8158	FA2:1 D

XT62

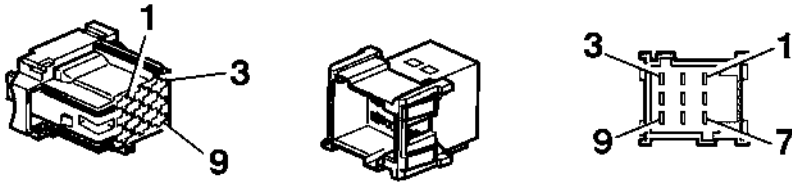

T3019929

Pin no:	Circuit function	Wiring no:	Diagram
1	Burglar alarm control	039	EM1:1 B
3	Ground	1	GM:2 E
4	EBS footbrake valve ground	072	EM1:1 B
5	EBS footbrake sensor power supply	056	EM1:1 B
6	EBS footbrake valve	040	EM1:1 B
7	Climate compressor power supply before pressure sensor	489	HY:2 C
8	Climate compressor power supply	462	HY:3 D
9	Heated mirror power supply. Windscreen heater relay control	4	IF1:3 B
10	Low speed wiper motor power supply	504	GM:3 C
11	High speed wiper motor power supply	502	GM:2 C
12	Power supply kl. 15	501	GM:2 C
13	EBS footbrake sensor switch	5077	EM1:1 B
15	Wiper status	509	GM:2 D

XT63_HYB

Pin no:	Circuit function	Wiring no:	Diagram
1	Water temp sensor	78	IO1_Hyb:4 D
2	Water temp sensor	79	IO1_Hyb:4 D

XT65

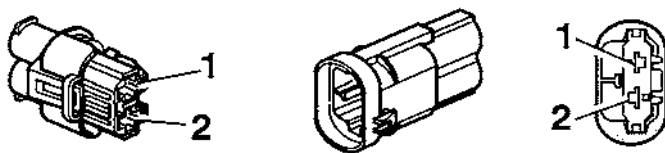

T3019931

Pin no:	Circuit function	Wiring no:	Diagram
1	Power supply kl. 30 for windscreen heater	238	IF1:4 A

XT70

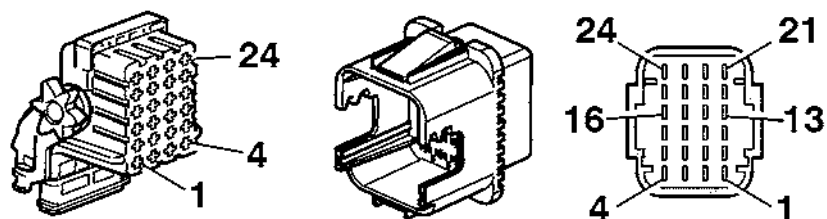

T3019802

Pin no:	Circuit function	Wiring no:	Diagram
1	EBS front module dedicated CAN L	0147	EM1:2 D
2	EBS front module dedicated CAN H	0148	EM1:2 D
3	EBS front module +24V power supply	5079	EM1:1 D
4	EBS front module ground	5080	EM1:2 D
5	EBS right inlet valve control	539	EM1:3 D
6	EBS right outlet valve control	540	EM1:3 D
7	EBS left outlet valve control	557	EM1:4 D
8	EBS left inlet valve control	556	EM1:4 D
9	EBS solenoid valve ground	1012	EM1:4 D
10	Ground	1	IN:3 E
11	Burglar alarm control	0039	IN:3 D
12	Alarm siren power supply	2303	IN:3 D
13	U mini sensor steering angle front	0119	FO:2 D
14	U maxi sensor steering angle front	0120	FO:2 D
15	Power supply kl. 15	274	FO:1 B
16	Electronic steered axle sensor ground	1081	FO:2 D
17	Ground	1	FO:0 D
21	Sensor oil level	8079	FO:0 B
22	Disc brake pad sensor	8040	BK:3 D
23	Disc brake pad sensor	867	BK:3 C

List of wiring numbers

0010	(XA:0 D)	0380	(EM2:2 C)	107	(JB3_Hyb:2 D)
0011	(XA:0 D)	0384	(NE:3 C)	108	(JB3_Hyb:2 E)
0012	(XB:0 E)	0403	(IN:2 D)	113	(CU50_Hyb:2 C)
0013	(XB:0 E)	0405	(BM:4 C)	119	(GH1:0 C)
0023	(BA:1 C)	0411	(BK:1 B)	141	(BA:1 C)
0039	(IN:3 D)	0412	(BK:1 B)	142	(BM:2 D)
0045	(EM2:4 C)	0413	(IO:3 C)	147	(AA:1 C)
0046	(EM2:4 C)	0414	(IO:3 C)	158	(DQ:2 B)
0048	(JB3_Hyb:2 C)	0415	(EM2:1 B)	169	(AB:0 A)
0049	(JB3_Hyb:2 C)	0416	(EM2:1 B)	202	(GQ:2 B)
0056	(BM:3 C)	0460	(NB:0 C)	203	(BM:1 B)
0064	(DQ1:2 D)	0461	(NB:0 C)	208	(NA:1 C)
0065	(DQ1:2 D)	0462	(GF1:1 C)	211	(AI:0 C)
0066	(DQ1:2 D)	0463	(GF1:1 C)	214	(AG:0 B)
0067	(DQ1:2 B)	0810	(DQ1:1 D)	215	(IF2:1 C)
0068	(DQ1:2 B)	0811	(DQ1:1 D)	229	(BM:1 B)
0076	(DQ1:2 D)	0861	(DQ1:1 D)	237	(JB3_Hyb:2 C)
0086	(DQ1:2 D)	0862	(DQ1:1 D)	239	(JB3_Hyb:2 D)
0087	(DQ1:3 D)	1	(AA:1 E)	243	(KA:0 C)
0088	(DQ1:3 D)	3	(GC3:1 B)	247	(KA:1 A)
0089	(DQ1:2 D)	4	(IF2:3 B)	260	(FA:4 B)
01	(JB3_Hyb:2 D)	7	(NA:4 C)	263	(IN:1 B)
02	(JB3_Hyb:2 D)	12	(BA:3 B)	270	(DQ1:0 B)
040	(EM1:1 B)	22	(AE:1 B)	273	(AI:1 D)
048	(JB4_Hyb:2 C)	24	(BK:0 B)	274	(FA:3 C)
049	(JB4_Hyb:2 C)	25	(AB:2 C)	275	(NC:1 B)
050	(JB4_Hyb:2 E)	30	(GF:4 A)	291	(CU20:0 B)
051	(JB4_Hyb:2 E)	31	(AC:0 E)	292	(CU20:0 B)
056	(EM1:1 B)	37	(GQ:0 D)	301	(GC3:1 B)
064	(EN1:4 A)	38	(GC3:3 B)	302	(GQ:1 D)
066	(EN1:4 A)	39	(GF:4 A)	303	(GQ:2 D)
072	(EM1:1 A)	45	(GH1:1 B)	304	(GC2:2 B)
088	(DQ1: D)	47	(IR:0 B)	305	(GC2:2 D)
089	(CU50_Hyb:2 C)	59	(BA:1 C)	307	(GB2:2 C)
090	(CU50_Hyb:2 C)	60	(GB2:0 C)	310	(GQ1:1 B)
091	(CU50_Hyb:2 C)	62	(GB1:3 A)	311	(GQ1:1 D)
092	(CU50_Hyb:2 D)	64	(GA2:1 A)	312	(GQ1:1 B)
093	(CU50_Hyb:2 D)	69	(GB2:1 B)	313	(GA2:1 A)
094	(CU50_Hyb:2 D)	76	(BK:1 D)	321	(GC2:3 B)
0119	(FO:2 C)	77	(JB3_Hyb:2 E)	322	(GC2:3 B)
0120	(FO:2 C)	78	(IO1_Hyb:4 D)	323	(GC2:4 C)
0147	(EN1:1 B)	79	(IO1_Hyb:4 D)	352	(BK:0 C)
0148	(EN1:1 B)	81	(CU20:1 D)	370	(GB2:2 B)
0149	(EM1:0 D)	82	(CU20:1 D)	373	(GA1:3 B)
0150	(EM1:0 D)	83	(KA:0 D)	386	(BA:1 C)
0151	(CU20:1 C)	86	(DU:2 C)	388	(GC5:3 C)
0375	(IM:2 B)	87	(BK:1 B)	413	(HJ:4 D)
0376	(EM2:1 C)	88	(BA:4 B)	414	(HJ:4 D)
0377	(EM2:1 C)	89	(NB:2 C)	430	(IF2:2 C)

432	(IF2:2 C)	808	(CU22:3 B)	2126	(AE:1 D)
436	(IM:1 B)	813	(FA:0 B)	2128	(GA2:4 D)
437	(GC5:1 C)	814	(FA:0 B)	2132	(HJ:3 B)
444	(IU:2 C)	815	(FA:0 B)	2223	(AA:0 B)
447	(IU:3 C)	816	(FA1:0 B)	2226	(AB:1 D)
448	(IU:3 C)	824	(CU20:3 D)	2227	(IM:4 B)
451	(IU:2 C)	825	(BM:2 C)	2229	(AB:3 C)
452	(GF1:2 C)	851	(HJ:4 D)	2230	(FC:1 B)
456	(AG:3 D)	867	(BK:3 C)	2231	(AG:3 C)
462	(HY:3 E)	879	(FA2:1 D)	2232	(IQ:3 A)
463	(HY:2 C)	880	(FA1:2 D)	2233	(FO:1 B)
469	(IQ:2 B)	881	(FA:2 D)	2234	(NA:3 C)
470	(IQ:2 B)	899	(FA:1 D)	2302	(IR:1 B)
476	(HJ1:2 B)	1012	(EM1:4 D)	2303	(IN:3 D)
484	(IM:1 B)	1018	(BA:0 C)	2304	(HJ:1 A)
489	(HY:2 C)	1025	(BA:0 C)	2306	(AA:1 A)
501	(GM:3 B)	1026	(BA:4 C)	2307	(AE:2 C)
502	(GM:2 D)	1029	(DQ1:3 D)	2309	(EM1:4 C)
503	(GM:1 C)	1030	(DQ1:3 D)	2310	(AH:4 C)
504	(GM:3 D)	1031	(DQ1:3 D)	2311	(GA2:4 D)
506	(GQ:4 C)	1032	(DQ1:3 D)	2312	(BT:2 A)
507	(GM:2 C)	1033	(DQ1:4 D)	2315	(AG:4 E)
509	(GQ:4 A)	1034	(DQ1:4 D)	2316	(GQ:0 B)
539	(EM1:3 D)	1035	(DQ1:4 D)	2317	(AI:3 C)
540	(EM1:3 D)	1036	(DQ1:1 D)	2320	(DN:3 B)
556	(EM1:4 D)	1037	(DQ1:1 D)	2323	(CU22:1 B)
557	(EM1:4 D)	1038	(DQ1:2 D)	2325	(AJ:2 D)
602	(GB1:1 C)	1039	(DQ1:3 C)	2327	(BT:0 B)
603	(GB1:2 C)	1081	(FO:2 C)	2328	(AA:2 B)
604	(GC5:0 B)	1124	(EM2:1 B)	2329	(CU23:3 B)
605	(GQ:2 D)	1140	(BA:4 B)	2331	(IR:4 A)
606	(AJ:0 D)	1141	(BA:4 B)	4002	(HJ:1 D)
608	(GD:1 C)	1149	(AC:2 B)	4003	(HJ:1 B)
618	(BK:4 B)	1150	(AE:1 E)	4004	(HJ:1 D)
632	(GF:3 D)	1155	(FA:3 C)	4014	(IQ:1 C)
634	(GF:3 D)	2014	(HY:0 C)	4015	(IQ:1 C)
635	(GC3:4 B)	2023	(AB_Hyb:3 C)	4060	(BA:0 B)
651	(BK:4 B)	2025	(AH:1 C)	4306	(NA:3 C)
661	(BA:2 C)	2057	(NB:3 D)	4308	(IA:3 C)
663	(GB1:3 B)	2070	(DQ1:3 D)	4309	(IU:1 C)
666	(GH1:4 B)	2071	(DQ1:4 D)	4313	(IM:2 D)
713	(JB4_Hyb:2 B)	2072	(DQ1:4 D)	4314	(IM:2 D)
714	(JB4_Hyb:2 B)	2117	(AC:2 A)	4315	(IM:1 D)
715	(JB4_Hyb:2 D)	2120	(NB:3 B)	4316	(IM:1 D)
716	(JB4_Hyb:2 D)	2121	(DQ:1 B)	4317	(IM:1 D)
718	(BK:0 C)	2122	(BA:1 C)	4318	(IM:1 D)
719	(BK:3 B)	2123	(BA:3 B)	4321	(GH1:1 C)
720	(BK:1 C)	2124	(BA:3 D)	4322	(GH1:3 C)
775	(BK:3 B)	2125	(ND:2 C)	4323	(IU:2 D)
803	(BK:0 B)	2127	(DN:3 C)	4324	(IU:2 D)

4325	(IU:2 D)	5092	(EM2:2 C)	8120	(BA:3 C)
4326	(IU:3 D)	5093	(EM2:3 C)	8121	(BA:2 C)
4327	(IU:3 D)	5094	(GM:1 C)	8122	(IO:0 B)
4328	(IU:3 D)	5095	(GM:1 B)	8123	(IO:0 B)
4462	(HJ1:1 D)	5098	(AJ:0 D)	8129	(DU:3 C)
4467	(BK:1 D)	5101	(CU22:0 C)	8131	(IO:1 C)
5028	(BA:1 D)	5102	(BA:1 C)	8132	(IO:2 C)
5031	(DQ1:1 C)	5108	(BM:3 C)	8133	(IO:2 C)
5048	(EM2:1 B)	5109	(DQ1:4 C)	8134	(IO:3 C)
5050	(EM2:2 C)	8040	(BK:3 D)	8136	(NE:4 C)
5066	(AC:1 A)	8067	(BA:1 C)	8137	(NB:0 C)
5067	(AC:2 B)	8077	(FA:1 D)	8138	(NB:1 C)
5068	(AC:2 C)	8079	(FO:1 B)	8140	(FA:2 D)
5069	(AC:2 C)	8083	(BK:3 B)	8142	(FA:2 D)
5070	(AC:2 B)	8093	(BA:1 C)	8148	(FA2:1 B)
5072	(CU20:1 A)	8095	(NB:1 C)	8149	(FA2:2 B)
5074	(BA1:2 B)	8098	(DU:4 B)	8150	(FA2:2 B)
5077	(EM1:1 A)	8100	(IO:0 C)	8156	(FA2:0 D)
5079	(EN1:1 B)	8104	(IO:0 C)	8157	(FA2:0 D)
5080	(EN1:1 B)	8108	(NE:0 C)	8158	(FA2:1 D)
5081	(EM1:1 D)	8110	(NA:4 C)	8159	(FA1:1 D)
5082	(EM1:1 D)	8112	(DQ:4 B)	8160	(FA:1 D)
5083	(EM1:0 D)	8113	(DQ:4 D)	8161	(DQ:3 D)
5084	(EM1:0 D)	8115	(DQ:2 C)	8169	(NA:0 C)
5085	(EM2:4 B)	8116	(BK:4 B)	8170	(NE:2 C)
5089	(EM2:4 C)	8118	(NA:3 C)	8227	(BA1:3 B)
5091	(EM2:2 C)	8119	(BA:3 C)		

List of components

A03	Instrument cluster (BK:0 B) (1000)	A95	GSECU, gear selector gateway (DN:3 C) (1000)
A04A	Refrigerator (IR:4 C) (1007)	A101	Pack office (IR:3 D)
A06L	El. adjustable seat (IA:2 B) (1007)	A108	Control unit, NDS (Noxcare distribution unit) (CU23:0 C) (1057)
A06R	El. adjustable seat (IA:0 B) (1007)	A117B	TCM component group (EM2:1 D) (1057)
A07	Radio (IU:1 C) (1000)	A141	Control unit, HPCU (Hybrid Powertrain Control Unit) (CU53_Hyb:0 C) (1057C)
A07V12	Radio (IU1:1 C) (1000)	A143	Control unit, HIOM (IO1_Hyb:0 B) (1000)
A10	CD player (IU:2 E) (1006)	B03	Sensor, footbrake valve (EM1:2 A) (1501)
A11	Control unit, door lock (IM:1 C) (1006)	B04	Sensor, engine speed, crankshaft (CU21:2 B) (1030)
A13D	Control unit, TECU (Automatic transmission) (DN:0 C) (1499)	B05	Sensor, engine speed, camshaft (CU21:3 B) (1030)
A14	Control unit, EMS (Engine Management System) (CU20:0 B/CU21:0 B) (1030)	B07	Sensor, fuel level (BK:1 D) (1040)
A16	Control unit, ECS (Electronic Controlled air Suspension) (FA:0 C/FA1:0 C/FA2:0 C) (1000)	B07B	Sensor, fuel level (BK:1 D)
A17	Control unit, VECU (Vehicle ECU) (BA:0 C) (1000)	B10B	Sensor, oil level (FO:0 C) (1040)
A19B	Control unit, GECU (gear selector ECU) (DQ1:4 B) (1007)	B12B	Sensor, tachograph/speedometer (BM:3 E) (1494)
A20	Control unit, Immobiliser (IM:4 C) (1000)	B12C	Sensor, tachograph/speedometer (BM:0 E) (1499)
A21	Control unit, EBS (Electronic Brake System) (EM1:0 C/EM2:1 B) (1000)	B13B	Sensor, wheel speed, lhs. 1:st front axle (EN1:1 D) (1040)
A27	Control unit, LCM (Light Control Module) (GQ:1 C) (1000)	B14B	Sensor, wheel speed, rhs. 1:st front axle (EN1:1 D) (1040)
A28B	Control unit, ADR battery main switch (AC:2 C) (1435)	B17	Sensor, wheel speed, lhs. 2:nd driven rear axle (EN3:1 D) (1040)
A31	Control unit, burglar alarm (IN:0 C) (1006)	B18	Sensor, wheel speed, rhs. 2:nd driven rear axle (EN3:1 D) (1040)
A32B	Control unit, parking heater (HJ:1 C) (1007)	B21	Sensor, coolant temperature, engine (CU20:2 B) (1030)
A32C	Control unit, parking heater (HJ1:1 C) (1007)	B22	Sensor, outside temperature (BK:1 E) (1083)
A33	Tachograph (BM:1 B) (1006)	B24A	Sensor, air pressure, bogie lift bellow(FA2:0 D) (1040)
A36	Control unit, BBM (Body Builder Module) (IO:1 C) (1000)	B25	Sensor, accelerator pedal (BA:4 E) (1000)
A42	Componet group transmission, (contains B26, Y21, Y22, and Y26) (DN:2 D)	B28	Sensor, chassi level, front axle (FA1:2 D/FA2:1 D) (1040)
A57	Control unit, Transmission (DQ1:0 C) (1499)	B28R	Sensor, chassis level, front axle RHD (FA1:1 D/FA2:1 D)
A59	Control unit, RAS (Rear Axle Steering) (FO:1 B) (1040)	B29	Sensor, chassis level, lhs. rear axle (FA:1 D/FA1:2 D/FA2:2 D) (1040)
A63L	Control unit, APM (air power management) (FC:1 B) (1460)	B30	Sensor, chassis level, rhs. rear axle (FA:2 D/FA1: 2 D/FA2:2 D) (1040)
A63R	Control unit, APM (air power management) (FC1:1 B)	B37	Sensor, boost pressure and boost temperature (CU21:1 B) (1030)
A64	Control unit, Turn indicator control (GQ:1 C) (1000)	B40B	Sensor, brake lining wear indicator, lhs. 1:st front axle, (EN1:1 D) (1040)
A71	Engine running time counter (KA:3 C) (1007)	B41B	Sensor, brake lining wear indicator, rhs. 1:st front axle (EN1:1 D) (1040)
A72	Component group, sensors, transmission (DQ1:1 D) (1499)	B42B	Sensor, brake lining wear indicator, lhs. 1:st driven rear axle, (EN3:1 D) (1040)
A73	Citizen Band unit (IR:3 B) (1006)		
A76D	Cigarette lighter module (IA:4 C) (1000)		
A94_B	FMS Gateway, Fleet Management System (BT:0 B) (1000)		

B43B	Sensor, brake lining wear indicator, rhs. 1:st driven rear axle, (EN3:1 D) (1040)	B146R2	Sensor, Disc brake pad, rear R1 (BK:3 E) (1040)
B44	Sensor, brake lining wear indicator, lhs. 2:nd driven rear axle, (EN3:1 D) (1040)	B147L1	Sensor, Disc brake pad, front L1 (BK:3 D) (1040)
B45	Sensor, brake lining wear indicator, rhs. 2:nd driven rear axle, (EN3:0 D) (1040)	B147R1	Sensor, Disc brake pad, front R1 (BK:3 D) (1040)
B49	Sensor, steering angle (EM2:1 A) (1000)	B149	Sensor, pressure trailer brake starting (EM2:4 D) (1007)
B49F	Sensor, steering angle, front (FO:1 E) (1040)	B158	Sensor, Level and Temp, NOxCare Tank (CU23:0 D) (1057)
B49P	Sensor, steering angle, pusher (FO:3 D)	B160B	Sensor, air filter restriction (BK:1 D) (1040)
B49R	Sensor, steering angle, rear for tag (FO:2 D) (1040)	B164L	Loudspeaker, left (IU1:2 B) (1006)
B50	Sensor, yaw-rate (EM2:1 A) (1040)	B164R	Loudspeaker, right (IU1:3 B)
B51	Sensor, fuel pressure (CU20:3 B) (1030)	B168	Sensor, brake lining wear indicator, rhs, tag or pusher axle (EN4:1 D) (1040)
B52	Sensor, water level, water separator (CU20:2 D) (1057)	B169	Sensor, brake lining wear indicator, lhs, tag or pusher axle (EN4:1 D) (1040)
B52B	Sensor, water level, water separator (CU20:2 D)	B170	Sensor, wheel speed, rhs, tag or pusher axle (EN4:1 D) (1040)
B55	Sensor, air pressure, suspension bellows, 3:th axle (FA2:0 D) (1040)	B171	Sensor, wheel speed, lhs, tag or pusher axle (EN4:2 D) (1040)
B56	Sensor, air pressure, suspension bellows, front axle (FA1:0 D/FA2:0 D) (1040)	B178	Sensor, brake lining wear indicator, lhs, driver rear axle (EN3:3 D) (1040)
B57	Sensor, air pressure, suspension bellows, lhs. rear (FA:1 D/FA1:1 D/FA2:1 D) (1040)	B179	Sensor, brake lining wear indicator, rhs, driver rear axle (EN3:3 D) (1040)
B58	Sensor, air pressure, suspension bellows, rhs. rear (FA:1 D/FA1:1 D/FA2:1 D) (1040)	B180	Sensor, wheel speed, lhs, driven rear axle (EN3:4 D) (1040)
B60LF	Loudspeaker (IU:3 B) (1006)	B181	Sensor, wheel speed, rhs, driven rear axle (EN3:4 D) (1040)
B60RF	Loudspeaker (IU:3 B) (1006)	B186	Sensor, Level and Temp., NOxCare Tank, free right side (CU23:0 D)
B63	Microphone, (handsfree) (IU1:1 B) (1006)	B218	Sensor, Cooling Temp., ESS (CU53_Hyb:1 D) (1057C)
B90	Transmitter, movement sensor (IN:3 B) (1006)	B219	Sensor, Cooling Temp., MDS (CU53_Hyb:0 D) (1057C)
B91	Receiver, movement sensor (IN:3 B) (1006)	B220	Sensor, Cooling level, MDS (JB3_Hyb:0 E) (1057C)
B96	Sensor, NOx (CAN based) (CU23:4 B) (1057)	B221	Sensor, Cooling level, ESS (CU53_Hyb:0 D) (1057C)
B97	Sensor, exhaust temp (before catalyst) (CU23:1 D) (1057)	B227	Sensor, Water Temp. (IO1_Hyb:4 D) (1501)
B97C	Sensor, exhaust temp (before catalyst) (CU23:1 D)	E04	Lamp, loading light (GH1:4 D) (1040/1063)
B105A	Sensor, Climate unit compressor pressure (HY:3 D) (1501)	E07VL	Lamp, fog light, left (GC5:3 C) (1447)
B107DS	Sensor, Door open/closed (GH1:0 D/GH5:0 D) (1000)	E07VR	Lamp, fog light, right (GC5:4 C) (1447)
B107PS	Sensor, Door open/closed (GH1:1 D/GH5:0 D) (1000)	E11LC	Lamp, side marker light (GC4:2 C) (1040)
B118	Sensor, oil pressure (CU20:3 B) (1030)	E11LC2	Lamp, side marker light (GC4:1 C) (1040)
B119	Sensor, oil level and oil temp (CU20:3 B) (1030)	E11LF	Lamp, side marker light (GC4:3 C) (1040)
B139	Sensor, Rail pressure (CU21:1 B) (1030)	E11LF2	Lamp, side marker light (GC4:1 C) (1040)
B146L1	Sensor, Disc brake pad, rear L1 (BK:3 D) (1040)	E11LR	Lamp, side marker light (GC4:3 C) (1040)
B146L2	Sensor, Disc brake pad, rear L1 (BK:3 D) (1040)	E11LW	Lamp, side marker light (GC4:3 C) (1040)
B146R1	Sensor, Disc brake pad, rear R1 (BK:3 E) (1040)	E11RC	Lamp, side marker light (GC4:2 B) (1040)
		E11RC2	Lamp, side marker light (GC4:0 B) (1040)
		E11RF	Lamp, side marker light (GC4:2 B) (1040)
		E11RF2	Lamp, side marker light (GC4:1 B) (1040)

E11RR	Lamp, side marker light (GC4:3 B) (1040)	M11	Motor, cab tilt pump (KA:1 C) (1447)
E11RW	Lamp, side marker light (GC4:3 B) (1040)	M33F	Motor, steering pump, front (CU51_hyb:1 B) (1057A)
E12DS	Lamp, roof position light (GC2:2 B) (1006)	M33R	Motor, steering pump, rear (CU51_hyb:1 D) (1057A)
E12DSCC	Lamp, roof position light (GC2:2 B)	M35	Motor, cooling pump, MDS (CU53_Hyb:2 D) (1057C)
E12PS	Lamp, roof position light (GC2:1 B) (1006)	M36	Motor, cooling pump, ESS (CU53_Hyb:1 D) (1057C)
E12PSCC	Lamp, roof position light (GC2:1 B)	M37	EPS, cooling fan 1(CU53_Hyb:3 D) (1057C)
E13LS	Lamp, direction indicator (GC2:0 B) (1447)	M38	EPS, cooling fan 2(CU53_Hyb:2 D) (1057C)
E13RS	Lamp, direction indicator (GC2:2 D) (1447)	M42	Electrical water pump (AB_Hyb:1 C) (1057A)
E14L	Lamp, beacon warning lamp (GC2:3 D) (1047)	R01B	Heater, engine preheat (CU22:2 D) (1030)
E14R	Lamp, beacon warning lamp (GC2:4 D) (1047)	R02D	Heater, rear-view mirror (IF1:2 C/IF2:2 C) (1083)
E16DS	Lamp, instep light (GH1:2 C/GH5:2 C) (1083)	R02P	Heater, rear-view mirror (IF1:2 D/IF2:2 B) (1083)
E16PS	Lamp, instep light (GH1:2 C/GH5:2 C) (1083)	R10	Heater, fuel filter (CU22:4 C) (1057)
E17PS	Lamp, interior light (GH1:0 B/GH5:0 B) (1006)	R15	Windscreen heater (IF1:4 C) (1501)
E17DS	Lamp, interior light (GH1:1 B/GH5:0 B) (1006)	R22	Resistor, alternator control (AB:2 C/AE:1 C)
E26VL	Headlight module (GC5:0 C) (1447)	R27	Resistor, heater gasoil (CU22:3 C) (1030)
E26VR	Headlight module (GC5:2 C) (1447)	R38	Heater, NOxCare pump filter (CU23:2 B) (1057)
E27L	Tail lamp module (GC3:1 D) (1040)	R40BL	Heater, NOxCare (CU23:1 B) (1057)
E27R	Tail lamp module (GC3:3 D) (1040)	R40GN	Heater, NOxCare (CU23:1 B) (1057)
E48	Interior light, lower bed (GH1:3 D) (1007)	R40GR	Heater, NOxCare (CU23:0 B) (1057)
E51PS	Simple lamp, interior light, right (GH5:1 B) (1006)	R40SB	Heater, NOxCare (CU23:2 B) (1057)
E52DS	Lamp, Roof (GH3:2 C/GH5:3 C) (1006)	R54	Heater, ESS (CU53_Hyb:4 D) (1057C)
E52PS	Lamp, Roof (GH3:2 C/GH5:3 C) (1006)	S02	Stalk switch, full-/dipped beam, direction indicator (GA1:2 B/GB1:1 B/GB2:2 A/GB2:0 A/GQ:1 B/GQ1:3 B) (1000)
G01A	Battery (AA:0 D/AC:0 C)	S03	Switch, loading lamps / working lamps (GH1:4 B) (1000)
G01B	Battery (AA:0 D/AC:0 C)	S04	Switch unit, climate fan (HY:1 B) (1000)
G02	Alternator (AB:1 D/AE:0 C) (1030)	S06	Stalk switch, windscreen wiper, selector type (GM:3 B) (1000)
G06	Electric machine, hybrid (CU50_Hyb:3 C) (1057A)	S08B	Switch, differential gear lock, rear wheels (DU:3 B) (1000)
G07	ESS (Energy Storage System) (CU53_Hyb:4 A) (1057C)	S09A	Switch, differential gear locks, inter-axles and rear wheels, selector type (DU:2 B) (1000)
H06	Siren (IN:3 D) (1040)	S15	Switch, starting (AB:1 B/AE:1 B) (1000)
H09	Horn, electric (GQ1:3 D) (1447)	S21A	Switch, parking heater (HJ:1 B) (1007)
H10	Buzzer, reverse (GC3:4 D)	S21D	Switch, parking heater (HJ1:1 B) (1007)
M01	Motor, windscreen wiper (GM:2 D) (1501)	S22A	Switch, levelling control, headlights (GC5:1 B) (1000)
M02	Motor, windscreen washer pump (GM:0 D) (1447)	S23	Switch, roof hatch, selector type (IQ:1 B) (1007)
M03	Motor, headlamp high pressure washer pump (GM:1 D) (1447)	S24	Stalk switch, retarder, selector type (BA:3 D) (1000)
M04	Motor, starter motor (AA:3 D/AC:3 D) (1030)	S26_L	Switch, cab tilt pump (KA:1 C) (1447)
M06DS	Motor, window winder (IQ:4 D) (1083)	S26_R	Switch, cab tilt pump (KA:1 C)
M06PS	Motor, window winder (IQ:2 D) (1083)		
M09DS	Motor, door lock (IM:1 D) (1083)		
M09PS	Motor, door lock (IM:1 D) (1083)		
M10L	Motor, roof hatch (IQ:0 D)		
M10R	Motor, roof hatch (IQ:1 D) (1006)		

S28A	Switch, power take off 1 (DQ:2 B) (1000)	S125	Switch, body builder, ridge lighting (NB:4 B) (1000)
S30	Switch unit, multi-function display (BK:2 A) (1000)	S126	Switch, body builder, machine on (NB:3 B) (1000)
S31A	Switch, ASR request (EM2:3 A) (1000)	S131	Switch, difficult terrain, increase engine RPM (BA:0 D) (1000)
S32A	Switch, Hill start aid (EM2:4 A) (1000)	S133	Switch, level control, rear axle suspension (FA:4 D) (1000)
S33	Switch, trailer brake (EM2:4 D) (1007)	S134	Switch, level memory, rear axle suspension (FA:4 E) (1000)
S38	Switch, ADR, emergency switch, cab (AC:2 A) (1007)	S135	Switch, present level, rear axle suspension (FA:4 C) (1000)
S39	Switch, ADR, emergency switch, exterior (AC:2 B) (1040)	S137A	Switch, PTO 2 request (DQ:4 D) (1000)
S45	Position switch, differential gear lock indicator, rear wheels, NC. or NO. (DU:3 C) (1040)	S137B	Switch, PTO 3 request (DQ:4 B) (1000)
S45R	Position switch, differential gear lock indicator, rear wheels, NC. or NO. (DU:4 C) (1040)	S146	Switch, R/+ and S/- (BA1:4 D) (1000)
S48A	Pressure switch, brake light, NO. (GD:4 B) (1000)	S147B	Switch, RPM regulation (BA1:2 C) (1000)
S49	Position switch, reverse lamps, NO. (GD:0 C) (1494)	S150	Pressure switch, range preselection (DC:3 C) (1030/1494)
S61	Position switch, seat belt lock, NC. (IA:3 C) (1007)	S151	Rheostat, temperature control (HJ:0 C/HJ1:0 C) (1007)
S67B	Switch unit, ECS (electronic controlled susp.), max rear air suspension (FA:2 E/FA1:3 D/FA2:3 D) (1000)	S156A	Switch, Optidriver2, gear shift selector (DN:3 E) (1000)
S68	Proximity switch, coolant level, NC (CU20:1 D) (1057)	S167	Switch, body builder disposal (NB:0 A)
S73	Switch, acoustic reverse warning (GD:2 C) (1006)	S181	Position switch, Reverse lamps, NO (GD:1 C)
S75	Switch, beacon warning light (GC2:3 B) (1006)	S185	Switch, 15t rear axle limitation (FA2:4 A) (1000)
S90	Position switch, Neutral (BA:3 B) (1494)	S205	Switch, auto neutral (EM2:4 A) (1000)
S95	Switch, Panic alarm (IN:2 B) (1006)	S212	Switch, tail lift (NB:0 A) (1000)
S96	Switch, Reduced set, Alarm (IN:2 B) (1006)	S229	Switch, full elect/full elect anticipation (IO1_Hyb:0 B) (1000)
S102	Switch, auto/manu (BA:2 B) (1000)	S230	Switch, cruise brake auto/manu, hybrid (BA:2 B) (1000)
S103	Switch, heated mirror, mirror adjustment (IF1:1 E/IF2:1 D) (1083)	S233	Switch, AC/forced (IO1_Hyb:3 A) (1000)
S105	Switch, hazard warning light (GQ:3 B) (1000)	U03_1C	Modulator, EBS, rear axle (EN3:3 B) (1040)
S106DS	Switch, passenger window winder (IQ:2 B) (1083)	U03_2C	Modulator, EBS, rear axle (EN3:0 B) (1040)
S106PS	Switch, passenger window winder (IQ:2 C) (1083)	U06A	Voltage converter (IR:0 B) (1000)
S107	Switch, driver window winder (IQ:3 C) (1083)	U06R10	Voltage converter 10A (IR:2 B) (1006)
S112	Switch, engine stop (CU21:4 B) (1030)	U06R15	Voltage converter 15A (IR:1 C) (1006)
S115	Switch, door lock (IM:1 A) (1007)	U06R15A	Voltage converter 15A (IR1:1 C)
S123	Switch, mirror defrost (IF1:0 B) (1083)	U10	Voltage converter, 12V ABS Trailer (GK:1 C) (1063)
S124C	Position switch, PTO 1 feedback (DQ:1 C) (1494)	U10T	Voltage converter, 12V ABS Trailer (GK1:1 C) (1063)
S124G	Position switch, PTO gearbox (DQ:3 C)	U11	Modulator, EBS, front axle (EN1:1 B) (1040)
S124J	Position switch, PTO 1 feedback (Allison) (DQ:1 C) (1494)	U15	Voltage converter (GK:2 C)
S124R	Position switch, PTO 1 (Allison) RHD (DQ:1 C)	U15T	Voltage converter (GK1:4 D) (1063)
		U21	Modulator, EBS, tag or pusher (EN4:1 B) (1040)
		U24	Voltage converter, 600VDC/24VDC/12VDC (CU52_Hyb:1 B) (1057C)
		U27	Power electronic converter (CU50_Hyb:1 B) (1057A)

U28	Voltage converter, auxiliary DC/AC converter (CU51_Hyb:2 C) (1057C)	X61R	Trailer connection, Plug 12V/12N, Rigid (GK:3 E) (1063)
V01	Diode (BA:1 B)	X61T	Trailer connection, Plug 12V/24N, Tractor (GK1:2 E) (1063)
V02	Diode (NB:3 B)	X62	Tail lift preparation (NC:3 C) (1040)
V07	Diode, Alarm indicator (IN:3 D) (1006)	X66	Connector, USB, Audio (IU1:2 E) (1000)
V08	Diode (AB:3 B/AE:2 C)	X67	Connector, AUX, Audio (IU1:1 E) (1000)
V09	Diode (AE:3 C) (EJB pos. D3)	X76	Junction box, HEC (CU52_Hyb:3 A) (1057C)
V10	Diode (AE:3 D) (EJB pos. D4)	X77	Junction box, hybrid (JB1_Hyb:1 A/JB2_Hyb:1 B) (1057C)
V11	Diode (BA:3 B) (EJB pos. D5)	X81	Ground bar, on hybrid area (JB5_Hyb:2 B) (1057C)
V12	Diode, central locking system (IM:3 C)	X82	Ground bar, on frame (JB5_Hyb:3 B) (1057C)
V14	Diode (DU:2 C)	X84	Radiator 1, hybrid (JB5_Hyb:0 C)
V15	Diode (KA:1 C) (EJB pos. D6)	X85	Radiator 2, hybrid (JB5_Hyb:0 B)
V17	Diode (GH1:0 C/GH5:0 C)	X86	Grid, hybrid (JB5_Hyb:2 D)
V18	Diode (NA:0 B) (EJB pos. D2)	Y02B	Solenoid valve, differential lock, rear wheels (DU:3 C) (1040)
W01	Antenna, radio (IU:4 B/IU1:4 C) (1000)	Y02P	Solenoid valve, differential lock, rear wheels (DU:3 C)
W02	Antenna, immobiliser (IM:4 C) (1000)	Y03A	Solenoid valve, differential lock, inter axles, rear (DU:2 C) (1040)
X02R	Trailer connection, ABS/EBS (GF:1 B) (1040/1063)	Y03P	Solenoid valve, differential lock, inter axles, rear (DU:2 C)
X02T	Trailer connection, ABS/EBS (GF:1 C) (1040/1063)	Y05	Solenoid valve, bogie lift (FA2:2 A) (1040)
X03R	Trailer connection, 15–pole unit (GF:4 B) (1040/1063)	Y07	Solenoid valve, EPG (Exhaust Pressure Governor) (CU20:2 D) (1030)
X03T	Trailer connection, 15–pole unit (GF:2 B) (1040/1063)	Y18A1	Solenoid valve, PTO (Power Take Off) LHD (DN:2 A) (1499)
X10	B+ pass through, cab (AA:3 B/AC:4 B) (battery connections)	Y18A2	Solenoid valve, PTO (Power Take Off) RHD (DN:1 A) (1499)
X22D	Socket, +24V main power supply (IR:4 B) (1000)	Y18B1	Solenoid valve, PTO (Power Take Off) LHD (DN:2 A) (1499)
X23	Socket, +24V accessories power supply (IR:0 E)	Y18B2	Solenoid valve, PTO (Power Take Off) RHD (DN:2 A) (1499)
X24	Socket, +24V accessories power supply (IR1:2 D)	Y18G1	Solenoid valve, PTO (Power Take Off) (DQ:1 C) (1499)
X24D	Socket, +24V accessories power supply (IR:0 A)	Y18G2	Solenoid valve, PTO (Power Take Off) (DQ:0 C)
X26	Connector, fleet management (BT:1 C) (1000)	Y18L1	Solenoid valve, PTO (Power Take Off) (DQ:3 C) (1499)
X35	Clockspring (BA1:3 D/GQ1:1 A) (1000)	Y18L2	Solenoid valve, PTO (Power Take Off) (DQ:3 C)
X36	CAN 1 inter connection box (XB:1 B) (1000)	Y18X	Solenoid valve, PTO (Power Take Off) (DQ:0 C) (1499)
X43	Plug, OBD (GF1:1 B) (1000)	Y18Y	Solenoid valve, PTO (Power Take Off) (DQ:0 C)
X44	Socket +24V, cubic storage (IR:4 D) (1007)	Y25	Solenoid valve unit, level control, air suspension (FA:1 A/FA1:1 A/FA2:1 A) (1040)
X45	Second fueltank ground connection (BK:0 E)	Y32	Fuel dosing pump, parking heater (HJ:4 D/HJ1:4 D) (1040)
X53	Plug, diagnostics (DQ1:2 A) (1000)		
X56R	Plug, ABS 24V, Rigid (GK:0 B) (1063)		
X56T	Plug, ABS 24V, Tractor (GK1:0 D) (1063)		
X57R	Plug, ABS 24V, Rigid (GK:1 B) (1063)		
X57T	Plug, ABS 24V, Tractor (GK1:1 D) (1063)		
X58R	Trailer connection, Plug 24V/12N, Rigid (GK:4 B) (1063)		
X59T	Trailer connection, Plug 24V/24N, Tractor (GK1:2 B) (1063)		

Y33A	Solenoid valve, UI (Unit Injectors) (CU21:0 D) (1030)	Y58B	Solenoid valve, ABS, left (EM1:3 D) (1040)
Y33B	Solenoid valve, UI (Unit Injectors) (CU21:1 D) (1030)	Y59B	Solenoid valve, ABS, right (EM1:4 D) (1040)
Y33C	Solenoid valve, UI (Unit Injectors) (CU21:1 D) (1030)	Y78	Solenoid valve, high pressure pump (CU21:4 C) (1030)
Y33D	Solenoid valve, UI (Unit Injectors) (CU21:1 D) (1030)	Y82	Solenoid valve, single H (DC:1 C) (1030)
Y33E	Solenoid valve, UI (Unit Injectors) (CU21:2 D) (1030)	Y89	Solenoid valve, NOxCare dosing unit (CU23:2 D) (1057)
Y33F	Solenoid valve, UI (Unit Injectors) (CU21:2 D) (1030)	Y90	Solenoid valve, NOxCare heating tank (CU23:3 C) (1057)
Y40A	Solenoid valve unit, front axle, air suspension (FA1:0 A/FA2:0 A)	Y91A	Solenoid valve, Jacob brake, No 1. (CU20:3 D) (1030)
Y40R	Solenoid valve unit, rear axle, air suspension (FA:0 A) (1040)	Y91B	Solenoid valve, Jacob brake, No 2. (CU20:3 D) (1030)
Y42	Clutch, magnetic, air conditioning compressor (HY:4 D) (1030)	Y112	Solenoid valve, EPV exhaust flap (CU20:3 D) (1030)
Y53	Control valve block, RAS (FO:3 D) (1040)	Y113	Solenoid valve, Waste gate (CU20:3 D) (1030)
		Y132	Solenoid valve, 3 way (CU53_Hyb:4 D) (1057C)

Abbreviations

ABS	Antilock brake system	L2H1	Sleeper cab
ACU	Alarm control unit	L3H1	Long sleeper cab
ADR	ADR adaptation	LF	Left front
AL306	Allison transmission 3000 series 6 speed	LHD	Left hand drive
APM	Air pressure management	LHS.....	Left hand side
ASR	Anti slip regulation	LOCK-ALL	Central door lock and cut off electricity of truck
AT2412D	Automated transmission 2400 Nm 12 speed	LR	Left rear
AUS	Australia	OBD.....	On board diagnostics
BBM.....	Body builder module	PEC	Power electronic converter
BBOX-L	Battery box left hand side	PS.....	Passenger side
BBOX-R.....	Battery box right hand side	PTO	Power take off
CLU	Central locking unit	PWM.....	Pulse width modulated
DS.....	Driver side	R.....	Right
EBS	Electronic brake system	RASEC	Rear axle steering-system, electronic control
ECS	Electronic controlled air suspension	RF.....	Right front
ECU	Electronic control unit	RHD.....	Right hand drive
EJB	Electrical junction box	RHS	Right hand side
ELCE-CK.....	Electrical complete kit for body builder	RIGID.....	Platform or tipper truck
EM-EC01	European community 2001 level EURO3	RPM.....	Revolutions per minute
EM-EC06	European community 2006 level EURO4	RR	Right rear
EMS.....	Engine management system	STO1309	Gearbox variant, 9 speed
ENG-VE7	Volvo engine 7 litre	STWPOS-L.....	Steering wheel position left hand side
EPG	Exhaust pressure governor	STWPOS-R	Steering wheel position right hand side
ESS	Energy storage system	SUSPL-EC.....	Air suspension, electronic control system levelling device
FMS	Fleet management system	TECU.....	Transmission electronic control unit
FSS-AIR	Air suspension, front	TRACTOR	Semi-trailer tractor
FSS-LEAF	Leaf suspension, front	TTYPER	Transport type, refuse
GSECU.....	Gear selector gateway	UADR	Without ADR adaptation
HIOM	Hybrid input output module	VECU.....	Vehicle electronic control unit
HPCU	Hybrid powertrain control unit	ZTO1006	Gearbox variant, 6 speed
L.....	Left	ZTO1109.....	Gearbox variant, 9 speed
LCM	Light control module		
L1H1	Short cab		

Feedback

One of our objectives is that workshop personnel should have access to correct and appropriate service manuals where it concerns fault tracing, repairs and maintenance of Volvo vehicles.

In order to maintain the high standards of our service information, your opinions and experiences when using this information would be greatly appreciated.

If you have any comments or suggestions, use "Argus dealer" or send them to us using the email address below.

VPCS technical team
Smalleheerweg 29
BE-9041 Gent
Belgium
technical.team@volvo.com
Fax +32 9 2556767

VOLVO TRUCKS. DRIVING PROGRESS

VOLVO

Volvo Truck Corporation

www.volvotrucks.com